

A Standard Smart Hotel TV with Pro:Centric® Smart and Direct

Enhance guests in-room experience and hotel brand image with the interactive smart solution, Pro:Centric® SMART. The LV661H series features SDK Tools, Pre-loaded Apps, and hospitality content management software, Pro:Centric® Direct (Optional), which enables you to create customized content. Also, its smart connectivity capabilities including SmartShare, SmartScreen, Bluetooth Sound Sync provide enhanced guests' in-room entertainment and convenience.



LV661H

- Pro:Centric® Smart
- Pro:Centric® Direct Ready
- Bluetooth Sound Sync & LG Sound Sync
- Commercial Swivel Stand
- Pro:Idiom®

screen size

43", 49"

Key Features



Smart Customization

Create your own solution along with LG's smart customization tools and content management software. With the tailored solution, hotel can elevate their brand to new levels.

Features

- Pro:Centric Smart SDK (HTML5, GEM, Flash)
- Pro:Centric Direct Ready
- Pre-loaded Apps



Enhanced Guests' Experience

Delight your guests with vivid picture quality and entertaining features including webOS 3.5 and its smart apps. It captivates guests' taste and brings them again.

Features

- webOS 3.5 & Magic Remote (Ready)



Smart Connectivity

Cross display boundaries freely and without hassle. With LG Smart Share, mirroring and content sharing between TV and other smart devices are made incredibly easy and user-friendly.

Features

- SmartShare, ScreenShare
- Bluetooth Sound Sync
- LG Sound Sync

Hospitality Features



Commercial Grade Stand

Expand the range of comfort for guests with a commercial grade stand. This allows guests to watch a TV from any angle. Also, for security purposes, the stand may be secured to its table.



External Speaker Out

Enhance the entertainment experience by adding an additional speaker. Guests listen to the TV audio from anywhere including rest-rooms.

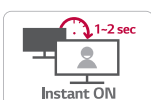

Instant On

Instant on function's high speed loading system saves and enables users to enjoy the contents immediately when they first turn on the TV.



Pro:Idiom®

Prevent any illegal copying of content by the widely used DRM (Digital Right Management).



SoftAP

SoftAP means Software enabled Access Point. This "virtual" Wi-Fi feature executes by software working on the device to create a wireless hotspot.

- * SoftAP should be set in installation menu after TV is on.
- * Miracast may not be operated at the same time.

A Standard Smart Hotel TV with Pro:Centric® Smart and Direct LV661H (EU)

Pro:Centric Smart is an elaborate and smart mode of control and customization for commercial televisions. With the customizable tools including HTML5, Java, and Flash, users can optimize the commercial TVs according to their purposes with IP-based programs. This expansion of control provides premium hotel services to guests without the need for a set-top box. Additionally, as the Pro:Centric Smart models are compatible with Pro:Centric Server Application, you can remotely manage TVs in a centralized coaxial infrastructure you already have.

Pro:Centric Smart Application Platform

LG Pro:Centric SMART offers extended customizable tools; HTML5, Java and Flash. With these, the partners can optimize Commercial TVs to edit and develop their own enhanced service design. Also, it gives visual impact on and delivers messages to customers as users intend.

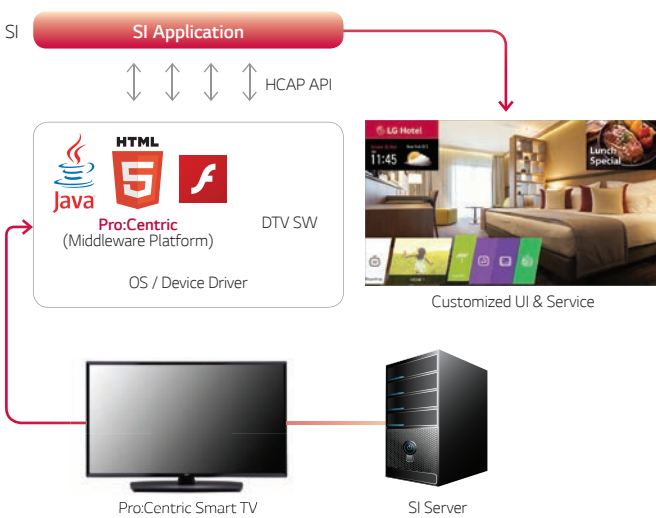

Pro:Centric Server Application

You can now differentiate your hotel with our customizable templates and pages which can be specialized for your property. Pro:Centric® provides you a solution that is easily customizable for your business.

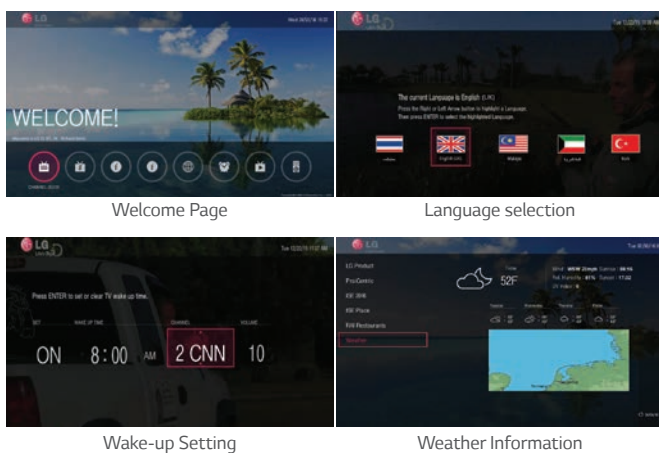

• Various Features

PCA serves the convenience of the guest through a Wake-up setting, Weather Information, Map Service, and much more functions that you can choose.

• Customizable Template & Page

Choose an alternative look & feel template based on your reference, and edit multiple sections with 40 pages of billboards by yourself with the web based tool.

Pro:Centric Direct Ready

Simply create your own templates and remotely manage TVs on the IP network with Pro:Centric Direct, LG's content management software. Pro:Centric Direct offers a free design template, along with customizable widgets and three types of theme templates (Cinematic-type, Grid-type, Bar-type) in order to promote branding and meet guests' tastes and needs. Its interactive solution, including 1-click service, and intuitive UI impress guests while elevating their hotel experience. Plus, for hoteliers, not only does it offer efficient content production and management, but it also maximizes advertisement effectiveness, which contributes to improving the hotel brand.

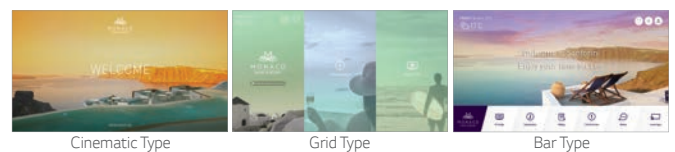

Smart Connectivity & Convenience



SmartShare

SmartShare allows users to share content more easily and quickly. It also searches for the content they want in order to share it more easily and accurately, thereby simplifying the process of sharing between various devices.



Bluetooth Sound Sync (Bluetooth 3.0)

Bluetooth Sound Sync enables users to listen to music on a mobile device through TV speakers via Bluetooth connection.

*Support devices for Bluetooth Sound Sync :
Android (above v4.4 KitKat) / iOS based Mobile Device



ScreenShare

Connect a smartphone or a laptop PC to TV via a Wi-Fi Direct connection. The TV will display the device's screen, and users can share their content and memories together.



SoftAP

SoftAP means Software enabled Access Point. This "Virtual" Wi-Fi feature executes by software working on the device to create a wireless hotspot.

* SoftAP should be set in installation menu after TV is on.
* Smart Mirroring may not be operated at the same time.

A Standard Smart Hotel TV with Pro:Centric[®] Smart and Direct LV661H (EU)

Dimensions (With Stand - Units : mm / kg)

43"

977 x 630 x 303 /
11.2

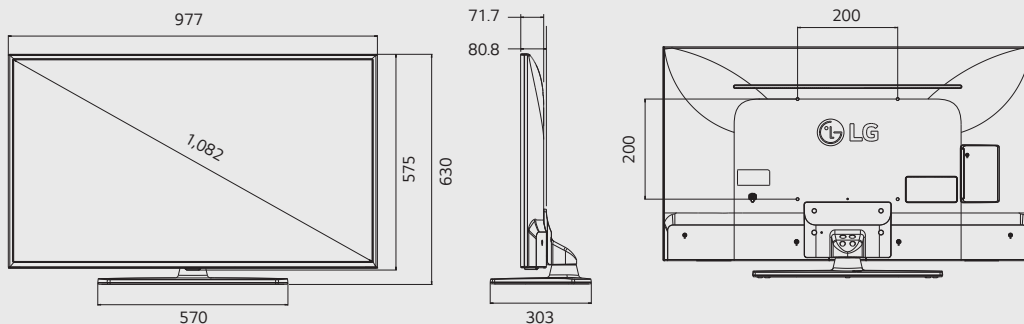

49"

1,110 x 705 x 303 /
14.5

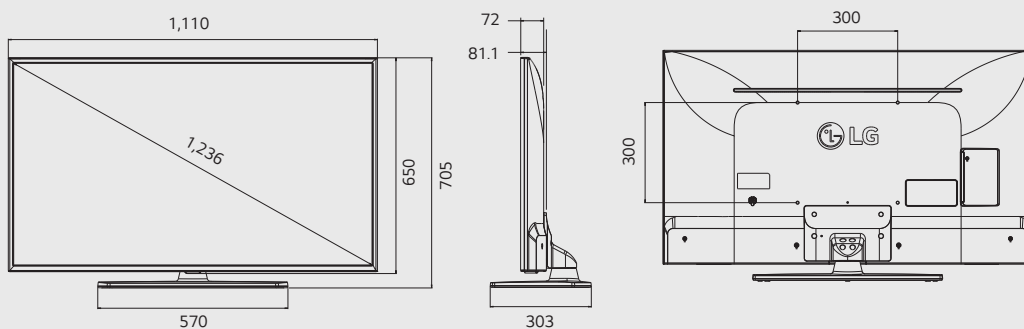

Jack Panels (Rear/Side)

- 1 RS-232C IN
- 2 H/P OUT
- 3 HDMI IN 1
- 4 COMPONENT IN / AV IN
- 5 LAN
- 6 SPEAKER OUT
- 7 LNB Satellite IN
- 8 ANTENNA / CABLE IN
- 9 HDMI IN 2
- 10 USB IN 1
- 11 USB IN 2

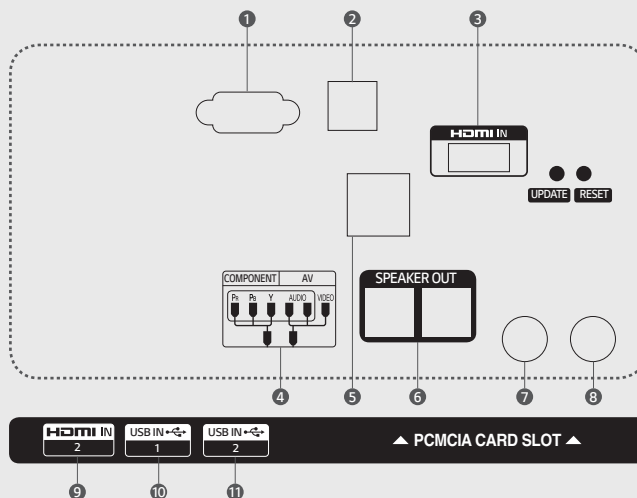

Specifications

LV661H (EU)

		43	49
DISPLAY	Type	Direct LED	
	Resolution	1,920 x 1,080 (FHD)	
	Brightness	400cd/m ²	
	Viewing Angle Degree	178° / 178°	
	Response Time	6	
BROADCASTING SYSTEM	Analog	PAL / SECAM	
	Digital	DVB-T2/C/S2	
VIDEO	Picture Engine	XD Engine	
	Real Cinema 24p (3:3 Pull down)	•	
	Aspect Ratio	• 6 modes (16:9, Original, 4:3, Vertical Zoom, All-Direction Zoom, Just Scan)	
AUDIO	Audio Output / Speaker System	10W + 10W / 2.0 ch	
	Sound Mode	• 6 modes (Standard, Cinema, Clear Voice III, Sports, Music, Game)	
	Clear Voice	• (Clear Voice III)	
SOLUTION	Type	Pro:Centric® Smart, V, Direct	
	Data Streaming (IP &RF)	•	
	RF	• (1 Tuner)	
	HCAP (SDK)	GEM / Flash /HTML5	
	Pro:Centric Application	PCA 3.7	
	Digital Right Management	Pro:Idiom	
SMART FEATURES	Smart UX	webOS 3.5, Commercial Smart Home, Web Browser, Pre-loaded Apps, SDP (Service Delivery Platform) compatibility, Magic Remote Ready	
	Connectivity	SoftAP, WiFi (ac), ScreenShare (Miracast), SmartShare, DIAL, Bluetooth Sound Sync, LG Sound Sync	
HOSPITALITY FEATURES	Hotel Mode, Lock Mode, Welcome Screen, Insert Image, External Speaker Out, Instant ON, One Channel Map, RJP Compatibility		
GENERAL FEATURES	Installation	EzManager, USB Cloning	
	Management	Wake on RF, WOL, SNMP, Remote Diagnostics, TVLink Interactive, IR Out, Multi IR Code, HTNG/HDMI-CEC	
	Setting Option	Auto Off/Sleep Timer, Smart Energy Saving, Motion Eye care	
	Anti-theft System	Kensington Lock, Credenza/Security Screw Hole, Lock Down Plate	
INTERFACE	Side	HDMI IN, USB (2), CI Slot	
	Rear	RF In (2), AV In, Video Component In (Phone Jack Type), HDMI Input, RS-232C, Headphone Out, RJ45, External Speaker Out (2)	
DIMENSION (Unit :mm)	Vesa	200 x 200	300 x 300
	W x H x D / weight (with stand)	977 x 630 x 303 / 11.2kg	1,110 x 705 x 303 / 14.5kg
	W x H x D / weight (packing)	1,147 x 660 x 175 / 13.9kg	1,296 x 770 x 171 / 17.2kg
POWER (Unit : Watts)	Voltage, Hz	100 - 240V, 50/60Hz	
	Max	100.2	113.6
	Typical	66.2	88.7
	Energy Saving (Min)	51	58.7
	Energy Saving (Med)	37.5	42.3
	Energy Saving (Max)	22.3	22.9
	Stand-by	0.3	
	ErP Class	A	
ECO	On Power Consumption (W)	68	77
	Luminance Ratio (%)	65	
	Mercury Content (mg)	0	
	Presence of Lead	Yes	
	Average Annual Consumption (kWh)	99	112
STANDARD APPROVAL	Safety	CB, CU TR	
	Environment	CE	
	Etc.	RoHS, ErP	

Download LG Commercial Display Mobile App



Learn more www.lg.com/b2b

You Tube youtube.com/c/LGCommercialDisplay

All screen images are simulated. Dimension and weights are approximate. Design, features and specifications subject to change without notice. © Copyright 2017 LG Electronics Inc. All Rights Reserved. Pro:Centric, the "LG" logo, XD Engine are registered trademarks or trademarks of LG Electronics Inc. Pro:Idiom is a registered trademark of Zenith Electronics LLC. All other trademarks or registered trademarks are the property of their respective owners.

