

OPERATION & MAINTENANCE MANUAL

Water-Cooled Centrifugal Chiller

Please read this installation manual completely for safety before installing the product. The purpose of this manual is to keep the user safe and to prevent any property damage. After reading this installation manual, please retain it for future reference thoroughly. Installation work must be performed in accordance with this installation manual by authorized personnel only.

Model : RCWF***P(200~3000RT)



P/NO : MFL68929307 (Rev 0)

www.lge.com

For your records

Staple your receipt to this page in case you need it to prove the date of purchase or for warranty purposes. Write the model number and the serial number here:

Model number : _____

Serial number : _____

You can find them on a label on the side of each unit.

Dealer's name : _____

Date of purchase : _____

1. CAUTIONS FOR SAFETY _ WARNING/CAUTION

It can be dangerous when moving, installing and placing the system for its high pressure, electric devices and heavy weight especially when lifting the unit in a limited space(rooftop, lifted structure, etc.).

Please read carefully the warnings and cautions on this manual and the labels attached on the unit, and follow the instructions.

Please follow the following instructions to prevent any injury or property damage

- It may result in an injury or damages when neglecting the instructions on in this manual.
The seriousness of the result can be classified as the following signs.
- Please note that any failure of system resulted by user's careless maintenance, natural disaster or the failure of the power cable shall not be warranted regardless of the warranty period.
- Please note that any part of this manual can be revised without notice for the product improvement.

WARNING

It can result in serious injury or death when the directions are ignored.

CAUTION

It can result in minor injury or product damage when the directions are ignored.

The meanings of the symbols used in this manual are as follows.

-  This is the symbol to call attention for the issues and operations that may cause danger.
To prevent the occurrence of the danger, read carefully and follow the instructions.
This is the symbol showing the how-to-use instruction in order to prevent danger.

-  Follow the direction.

1-1. WARNING

- Have all electric work done by a licensed electrician according to "Electric Facility Engineering Standard" and "Interior Wire Regulations" and the instructions given in this manual and always use a special circuit.
 - If the power source capacity is inadequate or electric work is performed improperly, electric shock or fire may result.
- Ask the dealer or an authorized technician to install the chiller unit.
 - Improper installation by the user may result in water leakage, electric shock, or fire.
- For re-installation of the installed product, always contact a dealer or an Authorized Service Center.
 - There is risk of fire, electric shock, explosion, or injury.
- Make sure to equip the circuit breaker and fuse.
 - Improper wiring or installation may cause fire or electric shock.
- Do not disassemble, repair or reconfigure the unit.
 - LG Electronics is not responsible for the any damage or loss from the arbitrary disassembly, repair or reconfiguration of the unit.
- Make sure to ground the unit properly.
 - There is risk of fire or electric shock.
- Do not store or use flammable gas or combustibles near the chiller unit
 - There is risk of fire or failure of product.
- Do not reconstruct to change the settings of the protection devices.
 - If the pressure switch, thermal switch, or other protection device is shorted and operated forcibly, or parts other than those specified by LGE are used, fire or explosion may result.
- Install the unit on a foundation where the heavy weight can be supported.
 - Insufficient strength of the foundation to support the chiller operation may cause the unit failure or injury.

- Installing the product in small space requires separate measures to keep the leakage of the refrigerant within the safety limits in case of any leakage.
 - Consult the authorized dealer for appropriate measures to prevent the refrigerant leakage from exceeding the safety limits. The leakage of refrigerant exceeding the safety limit may result in dangerous situations due to the lack of oxygen level in the room.
- Securely install the cover of control box and the panel.
 - If the cover and panel are not installed securely, dust or water may enter the unit and fire or electric shock may result.
- Do not operate the unit arbitrarily.
 - Incorrect operation of the unit may cause dangerous situations such as unit defects, leakage or electric shock. Always consult the authorized dealer.
- Do not use damaged circuit breaker or fuse works correctly all the time.
 - It may cause fire, electric shock or injury.
- Keep the control panel from any water getting in.
 - Do not wash the control panel with water. It can cause electric shock or defects.
- When the product is soaked (flooded or submerged), contact an Authorized Service Center.
 - There is risk of fire or electric shock.
- Use a dedicated outlet for this unit.
 - There is risk of fire or electric shock.
- Make sure to charge only the exclusive refrigerant R134a when installing or moving to other place.
 - If a different refrigerant or air is mixed with the original refrigerant, the refrigerant cycle may malfunction and the unit may be damaged.
- Do not touch the power switch with wet hands.
 - There is risk of fire, electric shock, explosion, or injury.
- Ventilate before operating the chiller unit when gas leaked out.
 - Do not use a phone or operate the power switch at this time. It may cause fire or explosion.
- Do not put any heavy object on the top of the unit or climb on the unit.
 - It may cause defects or injury.
- Be careful with the rotating part.
 - Do not put your fingers or a stick to the rotating part. It can cause injury.
- Use the fuse and circuit breaker with rated capacity.
 - It may cause fire and defects.
- Redesigning the control box is prohibited.
 - Lock the control box with possible locking device and if you need to open the control box inevitably, turn off the main power first.
- Do not touch the wiring or a parts inside the panel.
 - It may cause electric shock, fire or defects.
- Follow the permitted pressure level
 - Follow the regulated pressure for cold water, cooling water, refrigerant etc.
- Do not change the set values.
 - Do not change the set values of the controller and safety devices. Operating with inappropriate setting can cause damages. When changing the setting values, please consult with the specialist.
- Be careful of fire, earthquake and lightning.
 - In case of any natural disaster such as fire, earthquake or lightning, immediately stop operating the unit. If you continue to operate the unit, it can cause a fire or electronic shock.
- Follow all safety code.
 - When operate the chiller, follow the precautions on the manual, tag, sticker and label.
- Use of undesignated refrigerant and oil is prohibited.
 - Do not use undesignated refrigerant, freezer oil and brine. It may cause serious effect to the compressor and parts defect.
- During the installation and service, shut down the power supply.
 - Electric shock can cause injury and death. Mark and check all switches so that the power is not recovered until the work is completed.

- Wear safety equipment
 - Wear safety glasses and work gloves. Be careful when installing or operating the chiller and operating the electrical components.
- Always run fluid through heat exchangers when adding or removing refrigerant charge.
 - Potential damage of the tube within the heat exchanger can be prevented. Use Appropriate brine solution in cooler fluid loops to prevent the freezing of heat exchangers when equipment is exposed to temperature below 0°C.
- Do not vent refrigerant relief valves within a building.
 - Outlet from relief valves must be vented outdoors in accordance with the latest edition of ANSI/ASHRAE(American National Standards Institute/American Society of Heating, Refrigeration and Air Conditioning Engineers) 15 (Safety Code for Mechanical Refrigeration). The accumulation of refrigerant in an enclosed space can displace oxygen and cause asphyxiation. Provide adequate ventilation in enclosed or low overhead areas. Inhalation of high concentrations of refrigerant gas is harmful and may cause heart irregularities, unconsciousness or death. Misuse can be critical. Refrigerant gas is heavier than air and reduces the level of oxygen. It can cause irritation to eyes and skin.
- Be careful of water leakage.
 - In case of any water leakage in the pump or pipe, immediately stop operating the unit. It may cause electric shock, electricity leakage or defects. Be careful of electric shock.
- Always ground the chiller during installation.
 - It may cause electric shock.
- Do not leave refrigerant system open to air any longer than necessary.
 - If the repair cannot be completed, seal the circuits to prevent any contamination or rust within the product, and charge dry nitrogen.
- Do not reuse compressor oil.
 - It can damage the product.
- During installation, make the specified grounding before supplying the power, and during the dismantling, remove the grounding line at the end of the task.
- Use appropriate meters for measurement. Otherwise, it may cause injury or electric shock.
- Check all power connected to the control panel or starter panel to be shut off while applying the power.
 - It may cause electric shock.
- Make sure to discharge the electric current before inspection or repair work.
 - It may cause injury or electric shock.
- Do not open the 2nd phase side of the current transformer when power is on.
 - High voltage could be discharged causing an electric shock.
- Remove foreign objects(working tools, wires, bolts, washers) after installation, inspection, and repair work.
 - They may cause injury, fire, or damage.
- When using a condenser, make sure to verify the complete discharge before applying the power again. (Re-powering within 5 min. is prohibited.)
 - It may cause electric shock, fire, damage, or malfunction.
- Change the condenser in case that the expansion exceeds the recommended limit.
 - It may cause electric shock, fire, damage, or malfunction.

1-2. CAUTION

Operation & Maintenance

- Always check for gas(refrigerant) leakage after installation or repair of product.
 - Low refrigerant levels may cause failure of product.
- Do not install the unit where combustible gas may leak.
 - There is risk of fire or failure of product
- Keep level even when installing the product.
 - Unleveled refrigerant can cause problems to the product.
- Do not use the product for special usage or location such as preserving animal/plant, precision machine, artifact, etc.
 - It may cause property damage.
- Use exclusive wire for the product. Use power cables of sufficient current carrying capacity and rating.
 - It may cause fire and electric shock.
- When installing the unit in a hospital, communication station, or similar place, provide sufficient protection against noise.
 - The inverter equipment, private power generator, high-frequency medical equipment, or radio communication equipment may cause the chiller to operate erroneously, or fail to operate. On the other hand, the chiller may affect such equipment by creating noise that disturbs medical treatment or image broadcasting.
- To protect the product from corrosion, do not install the product where it is exposed to sea wind(salt spray) directly. If necessary, please install shield.
 - It may cause product deformation and defects.
- Make the connections securely so that the outside force of the cable may not be applied to the terminals.
 - Inadequate connection and fastening may generate heat and cause fire. If the power cable got damaged, do not directly replace it, but call the service center for replacement first.
- Do not use the product in special environments.
 - Oil, steam and sulfuric steam can deteriorate the product performance or cause damage to the parts.
- Be careful when transporting the product.
 - When carrying the chiller, always consult with the specialized expert.
- When transporting the chiller, always follow the methods described in the manual.
 - If not, it can cause overturn, fall etc.
- Do not touch any of the refrigerant piping during and after operation.
 - Pipe during and after the operation can be hot or cold depending on the condition of the refrigerant flowing through the refrigerant pipe, compressor and refrigerant cycle parts.
Touching the pipes at this time can cause burns or frostbites.
- Turn on the main power 12 hours before starting to operate the product.
 - If you operate the product immediately after turning on the main power, it can severely damage the internal parts.
Keep the main power on while operating.
- Do not immediately turn off the main power after the product stops operating.
 - Wait at least 5 minutes before turning off the main power. Failure to do so can cause water leak or other issues.
- Do not operate the product with the panel or safety devices removed.
 - Rotating parts or high temperature/pressure parts can cause safety accidents.
- Be careful when disposing the product.
 - When disposing the chiller, request to the specialized expert.
- Use a firm stool or ladder when cleaning or maintaining the chiller.
 - It may cause an injury.
- Be careful of high temperature.
 - Be careful not to make body contact to the parts of the chiller in high temperature.
It may cause a burn.
- Be careful of high voltage.
 - Install separate wiring for the power and always install and use dedicated power supply and circuit breaker.
It can cause electric shock and fire.

- Be careful of chiller installation.
 - Keep enough clearance around the product for service and especially for air cooling type, install the product at well ventilated location where there is no obstacle.
- Harsh chemical, household bleach or acid cleaner should not used to clean outdoor or indoor coils of any kind.
 - These cleaners can be very difficult to rinse out of the coil and can accelerate corrosion at the fin/tube interface where dissimilar materials are in contact. Use environment friendly cleaner.
- Be careful when restarting the product.
 - When a safety device is triggered, remove the cause and then restart the product. Repeating the operation arbitrarily can cause fire and defect.
- Use appropriate tools.
 - Use tools appropriate for the repair work and calibrate the measuring devices accurately before using. Using inappropriate tools can cause an accident.
- Be careful of sound and odor.
 - If you hear a weird sound or smell an odor, immediately stop operating the system and contact the service center. It may cause fire, explosion or injury.
- Be careful of injury.
 - Check the safety label of the safety device. Follow the above precautions and the contents in the label. It may cause fire and injury. To prevent the formation of the condensed water, the pipe connected to the evaporator as well as the evaporator itself should be well insulated.
- Check.
 - Perform periodic checks. If any problem occurs, stop the operation and contact the service center. Insufficient check may cause fire, explosion or error.
- Do not attempt to bypass or alter any of the factory wiring.
 - Any compressor operation in the reverse direction will result in a compressor failure that will require compressor replacement.
- Do not use jumpers or other tools to short out components, or bypass the parts differently from recommended procedures.
 - Short-circuiting the control board ground line with other wires can damage the electric module or electric components.
- Water must be within design flow limits, and should be treated cleanly.
 - This make it possible to ensure proper machine performance and reduce the potential of tubing damage due to corrosion, scaling, erosion and algae. LG Electronics is not responsible for any damage caused by cooling water not treated or improperly treated.
- Consult a water treatment specialist for proper treatment procedures.
 - Hard scale may require chemical treatment for its prevention or remove.
- Do not overcharge refrigerant to the system.
 - Refrigerant overcharging results in higher discharge pressure with higher cooling fluid consumption. Also it can damage the compressor and increase the power consumption. Also it can damage the compressor and increase the power consumption.
- Do not add different type of oil.
 - It may cause abnormal operation of chiller.
- Turn controller power off before service work.
 - It secures safety and prevents damage to the controller.
- Maintain the compressor oil pressure to normal level.
 - Use proper safety precautions whem relieving pressure.
- Welding the evaporator head or nozzle part is not recommended.
 - If the part requires welding, remove the chilled water flow switch and entering/leaving fluid thermistors before welding.
 - After the welding is completed, reinstall the flow switch and thermistors.
 - Failure to remove these devices may cause component damage.
- Do not open the circuit breaker arbitrarily during the operation.
 - It may cause damage or malfunction.

- Do not operate with wet hand.
 - It may cause electric shock.
- During maintenance work, check whether all of the power lines connected to the control panel or starter panel are interrupted.
 - It may cause electric shock.
- When power is on, do not open the door of control panel or starter panel, and protective cover.
 - It may cause electric shock.
- Do not open the circuit breaker without permission while running.
 - It may cause damage or malfunction.
- Tighten bolts and screws with the specified torque.
 - Otherwise, it may cause fire, damage, or malfunction.
- Do not change electric or control devices arbitrarily.
 - It may cause fire, damage, or malfunction.
- Only the persons who have sufficiently studied the user's manual should operate the control panel or starter panel.
 - Otherwise, it may cause injury, fire, malfunction, or damage.
- Do not perform welding work near cables connected to the main unit.
 - Otherwise, it may cause fire or damage.
- Connect only the input/output signal cables specified in the drawing to the control panel or starter panel.
 - Otherwise, it may cause malfunction or damage.
- Use the rated electrical cables.
 - If not, it may cause fire or damage.
- Use specified parts for repair.
 - If not, it may cause fire or damage.
- Install the machine, control panel, and starter panel at a place where there is no combustible material.
 - Otherwise, it may cause fire.
- Do not exceed the voltage supply limit described in the relevant manual.
 - Otherwise, it may cause damage or malfunction.
- Connect the signal cables connected to the control devices following the circuit diagram.
 - It may cause damage or malfunction.
- Do not store the product in a place where is a flooding risk or a lot of moisture.
 - Otherwise, it may cause damage or malfunction.
- Do not use the indoor control panel or starter panel outside of the building.
 - Otherwise, it may cause damage or malfunction.

Thank you for purchasing the water cooled centrifugal chiller of LG Electronics.

Installation as instructed after reading this manual will ensure the safety, convenience and long lifetime of the unit. Please read this manual carefully for the correct installation and proper operation of the centrifugal chiller.

Once the installation completed, please run the start-up test and inspect according to the operating & maintenance manual.

* This manual describes the introduction, control, start-up test, maintenance, and trouble shooting of the chiller.

CONTENTS

3 1. CAUTIONS FOR SAFETY _ WARNING/CAUTION

3 1-1. WARNING

6 1-2. CAUTION

10 2. INTRODUCTION

10 2-1. General Information

10 2-2. System structure

11 2-3. Nomenclature

11 2-4. Name plate

12 2-5. Main unit conversions

14 3. STRUCTURE OF SINGLE STAGE CENTRIFUGAL CHILLER

14 3-1. Cycle of the chiller

15 3-2. Main components of the two stage centrifugal chiller

21 4. CONTROL SYSTEM

21 4-1. Components and Major Parts of the Control Panel

26 4-2. Components and Major Parts of the Starter Panel

27 4-3. Control Parts Attached on the Product

27 4-4. Basic Control Algorithm

28 4-5. BMS Support Function

28 4-6. Remote Control Signal and Status Signal Connection

29 4-7. Power Panel and Interface Signal

29 4-8. Central Monitoring Panel and Interface Signal

30 4-9. Start and Control Order

33 4-10. Product Protection Function

36 4-11. Checklists before inspection

37 4-12. Checklists after inspection

38 4-13. General Checklist

39 5. HMI

39 5-1. Start HMI

43 5-2. Home Screen Composition

50 5-3. Schedule

52 5-4. History

54 5-5. Device Setting

80 5-6. Environment Settings

90 5-8. Data Storage

90 5-7. Screen Saver

91 5-9. Web Function

93 6. START-UP

93 6-1. Delivery and Installation Check

95 6-2. Preparation for start-up

102 6-3. Start-up

105 6-4. Startup procedure after long-period of stoppage

106 6-5. System Shutdown

107 7. MAINTENANCE

107 7-1. Maintenance criteria

111 7-2. Periodic maintenance

117 7-3. Maintenance during off-season

118 7-4. Annual maintenance(1/2)

119 7-4. Table for Annual maintenance(2/2)

120 7-4. Table for Annual maintenance

121 7-5. Oil maintenance

123 7-6. General Maintenance

126 8. TROUBLESHOOTING

126 8-1. Causes and actions for alarms

139 9. Operation inspection record

139 9-1. Check list for operation record

2. INTRODUCTION

2-1. General Information

This manual describes the installation of water-cooled Single stage Centrifugal chiller using R-134a refrigerant and X30 controller applied.

2-2. System structure

Figure 1 shows the general parts location and components of the Single stage Centrifugal Chiller.

The location of control panel, type of water box, direction of inlet/outlet of the chilled/cooling water and some of the pipes may vary by model or the customer specifications. Please confirm with the approved drawings for the site.

Front view

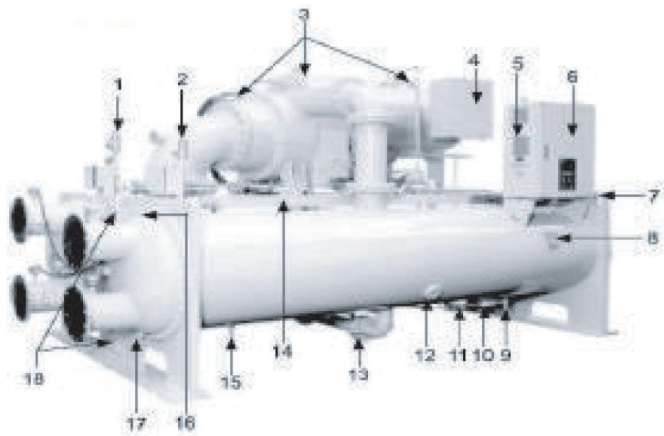

1. Evaporator relief valve
2. Condenser relief valve
3. Lifting hole (Compressor)
4. Terminal box for compressor motor
5. Main name plate
6. Control panel
7. Lifting hole (Condenser)
8. Condenser name plate
9. Service valve
10. Filter dryer
11. Sight glass
12. Condenser sight glass
13. Refrigerant return line (Orifice + Butterfly valve)
14. Wire tray (optional)
15. Service valve
16. Air vent (for Cooling water)
17. Drain (for Cooling water)
18. Bracket for combining Heat exchanger

Rear view

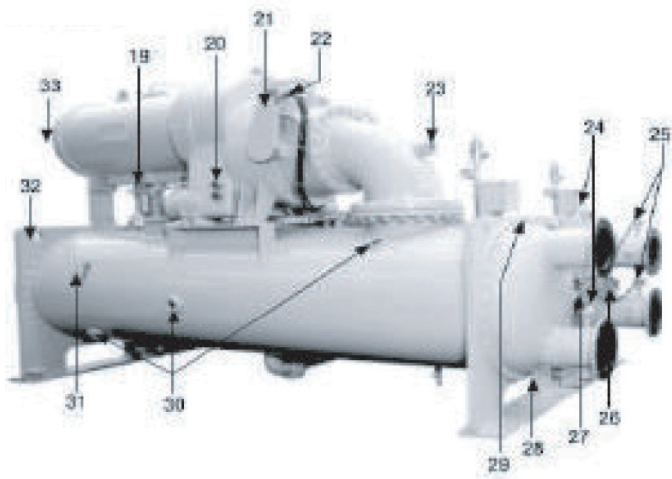

19. Oil filter
20. Oil tank sight glass
21. Chain cover
22. Actuator (Guide vane)
23. Sight glass (Compressor inlet)
24. Chilled water temperature sensor
25. Cooling water temperature sensor
26. Cooling water differential pressure switch
27. Chilled water differential pressure switch
28. Drain (for Chilled water)
29. Air vent (for Chilled water)
30. Evaporator sight glass
31. Evaporator name plate
32. Lifting hole (Evaporator)
33. Sight glass (Motor)

Figure 1. Components of Single stage Centrifugal Chiller

2-3. Nomenclature

The nomenclature of the Centrifugal Chiller is as shown in the figure 2.

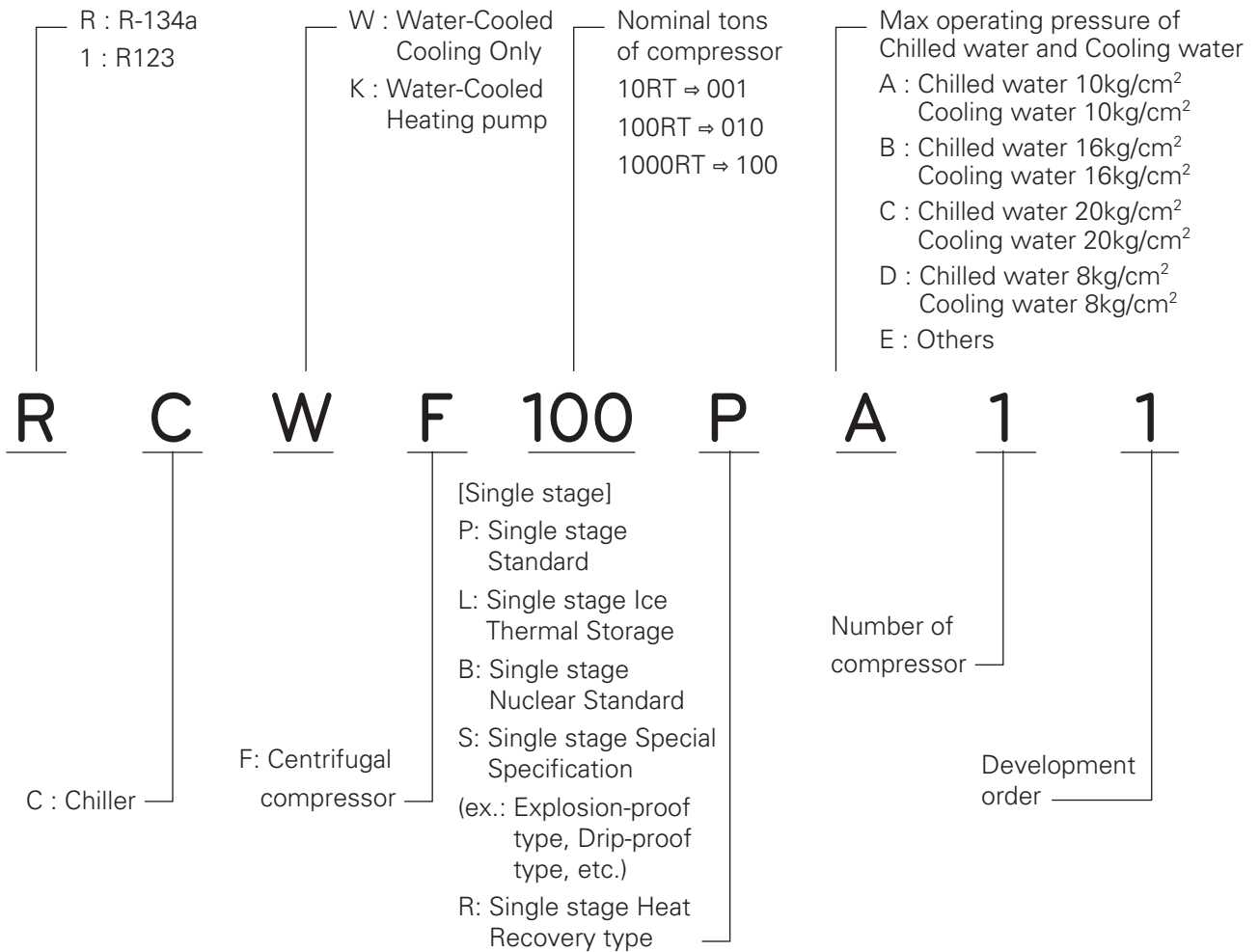
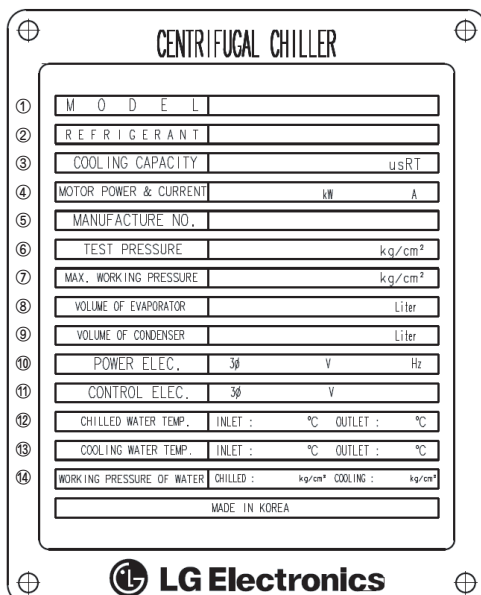

Figure 2. Nomenclature

2-4. Name plate

Name plate for the unit is attached on the right side of the control panel. General information of the product can be achieved from the plate, and the information can be used for quicker service later.



- ① Model name
- ② Refrigerant
- ③ Cooling capacity
- ④ Power and current required for motor
- ⑤ Manufacture's serial number
- ⑥ Internal pressure test pressure
- ⑦ Maximum working pressure (Design pressure)
- ⑧ Volume of Evaporator
- ⑨ Volume of Condenser
- ⑩ Power electricity
- ⑪ Control electricity
- ⑫ Temperatures of Chilled water inlet/outlet
- ⑬ Temperatures of Cooling water inlet/outlet
- ⑭ Maximum pressure of chilled water and cooling water

Fig. 3. Name plate

2-5. Main unit conversions

Temperature conversion table (°F ↔ °C)

- °F = (9/5 × °C) + 32
- °C = 5/9 × (°F - 32)

°F	°C	°F	°C	°F	°C	°F	°C	°F	°C
1	-17.2	31	-0.6	61	16.1	91	32.8	121	49.4
2	-16.7	32	0	62	16.7	92	33.3	122	50.0
3	-16.1	33	0.6	63	17.2	93	33.9	123	50.6
4	-15.6	34	1.1	64	17.8	94	34.4	124	51.1
5	-15.0	35	1.7	65	18.3	95	35.0	125	51.7
6	-14.4	36	2.2	66	18.9	96	35.6	126	52.2
7	-13.9	37	2.8	67	19.4	97	36.1	127	52.8
8	-13.3	38	3.3	68	20.0	98	36.7	128	53.3
9	-12.8	39	3.9	69	20.6	99	37.2	129	53.9
10	-12.2	40	4.4	70	21.1	100	37.9	130	54.4
11	-11.7	41	5.0	71	21.7	101	38.3	131	55.0
12	-11.1	42	5.6	72	22.2	102	38.9	132	55.6
13	-10.6	43	6.1	73	22.8	103	39.4	133	56.1
14	-10.0	44	6.7	74	23.3	104	40.0	134	56.7
15	-9.4	45	7.2	75	23.9	105	40.6	135	57.2
16	-8.9	46	7.8	76	24.4	106	41.1	136	57.8
17	-8.3	47	8.3	77	25.0	107	41.7	137	58.3
18	-7.8	48	8.9	78	25.6	108	42.2	138	58.9
19	-7.2	49	9.4	79	26.1	109	42.8	139	59.4
20	-6.7	50	10.0	80	26.7	110	43.3	140	60.0
21	-6.1	51	10.6	81	27.2	111	43.9	141	60.6
22	-5.6	52	11.1	82	27.8	112	44.4	142	61.1
23	-5.0	53	11.7	83	28.3	113	45.0	143	61.7
24	-4.4	54	12.2	84	28.9	114	45.6	144	62.2
25	-3.9	55	12.8	85	29.4	115	46.1	145	62.8
26	-3.3	56	13.3	86	30.0	116	46.7	146	63.3
27	-2.8	57	13.9	87	30.6	117	47.2	147	63.9
28	-2.2	58	14.4	88	31.1	118	47.8	148	64.4
29	-1.7	59	15.0	89	31.7	119	48.3	149	65.0
30	-1.1	60	15.6	90	32.2	120	48.9	150	65.6

Table 1. Temperature conversion table

Pressure conversion table (lb/in² ↔ kg/cm²)

• lb/in² = psi

ex) 1 lb/in² = 0.07030696 kg/cm²

lb/in ²	kg/cm ²	lb/in ²	kg/cm ²	lb/in ²	kg/cm ²	lb/in ²	kg/cm ²	lb/in ²	kg/cm ²
1	0.070	41	2.883	81	5.695	121	8.507	161	11.32
2	0.141	42	2.953	82	5.765	122	8.577	162	11.39
3	0.211	43	3.023	83	5.836	123	8.648	163	11.46
4	0.281	44	3.094	84	5.906	124	8.718	164	11.53
5	0.352	45	3.164	85	5.976	125	8.788	165	11.60
6	0.422	46	3.234	86	6.046	126	8.859	166	11.67
7	0.492	47	3.304	87	6.117	127	8.929	167	11.74
8	0.563	48	3.375	88	6.187	128	8.999	168	11.81
9	0.633	49	3.445	89	6.257	129	9.070	169	11.88
10	0.703	50	3.515	90	6.328	130	9.140	170	11.95
11	0.773	51	3.586	91	6.398	131	9.210	171	12.02
12	0.844	52	3.646	92	6.468	132	9.281	172	12.09
13	0.914	53	3.726	93	6.539	133	9.351	173	12.16
14	0.984	54	3.797	94	6.609	134	9.421	174	12.23
15	1.055	55	3.867	95	6.679	135	9.491	175	12.30
16	1.125	56	3.987	96	6.750	136	9.562	176	12.37
17	1.195	57	4.008	97	6.820	137	9.632	177	12.44
18	1.266	58	4.078	98	6.890	138	9.702	178	12.51
19	1.336	59	4.148	99	6.968	139	9.773	179	12.58
20	1.406	60	4.218	100	7.031	140	9.843	180	12.66
21	1.477	61	4.289	101	7.101	141	9.913	181	12.73
22	1.547	62	4.359	102	7.171	142	9.984	182	12.80
23	1.617	63	4.429	103	7.242	143	10.05	183	12.87
24	1.687	64	4.500	104	7.312	144	10.12	184	12.94
25	1.758	65	4.570	105	7.382	145	10.19	185	13.01
26	1.828	66	4.640	106	7.453	146	10.26	186	13.08
27	1.898	67	4.711	107	7.523	147	10.34	187	13.15
28	1.969	68	4.781	108	7.593	148	10.41	188	13.22
29	2.039	69	4.851	109	7.663	149	10.48	189	13.29
30	2.109	70	4.921	110	7.734	150	10.55	190	13.36
31	2.180	71	4.992	111	7.804	151	10.62	191	13.43
32	2.250	72	5.062	112	7.874	152	10.69	192	13.50
33	2.320	73	5.132	113	7.945	153	10.76	193	13.57
34	2.390	74	5.203	114	8.015	154	10.83	194	13.64
35	2.461	75	5.273	115	8.085	155	10.90	195	13.71
36	2.531	76	5.343	116	8.156	156	10.97	196	13.78
37	2.601	77	5.414	117	8.226	157	11.04	197	13.85
38	2.672	78	5.484	118	8.296	158	11.11	198	13.92
39	2.742	79	5.554	119	8.367	159	11.18	199	13.99
40	2.812	80	5.625	120	8.437	160	11.25	200	14.06

Table 2. Pressure conversion table

3. STRUCTURE OF SINGLE STAGE CENTRIFUGAL CHILLER

3-1. Cycle of the chiller

Single stage Standard Centrifugal Chiller

Cycle of the Centrifugal chiller is generally used for reciprocating same form as a screw refrigeration cycle, uses a high-pressure refrigerant R-134a. In this cycle, as shown in the Figure 1-1, the low temperature and low pressure refrigerant gas vaporized from the evaporator goes through guide vane and taken into the impeller of the compressor. The amount of gas taken in at this time is adjusted by the opening of the guide vane to control the chiller capacity. The refrigerant gas taken into the impeller is compressed to high temperature and high pressure refrigerant gas, discharged to condenser, and condensed after losing heat by cooling water in the condenser heat transfer tubes. The condensed refrigerant liquid goes through the orifice and goes into the lower part of the evaporator, is distributed evenly through all length of the evaporator by the distribution plate, and is evaporated after taking heat from the chilled water flowing inside the evaporator heat transfer tubes, and the same cycle is repeated. Part of the refrigerant liquid over-cooled in the condenser flows through valve, filter, sight glass, and is separated and flows to motor cooling and oil cooling system. The refrigerant liquid that entered the motor is sprayed to cool down the motor coil and returns to the evaporator. The refrigerant flowing to the oil cooling system flows to the plate type heat exchanger (oil cooler), and the refrigerant leaving the heat exchanger returns to the evaporator.

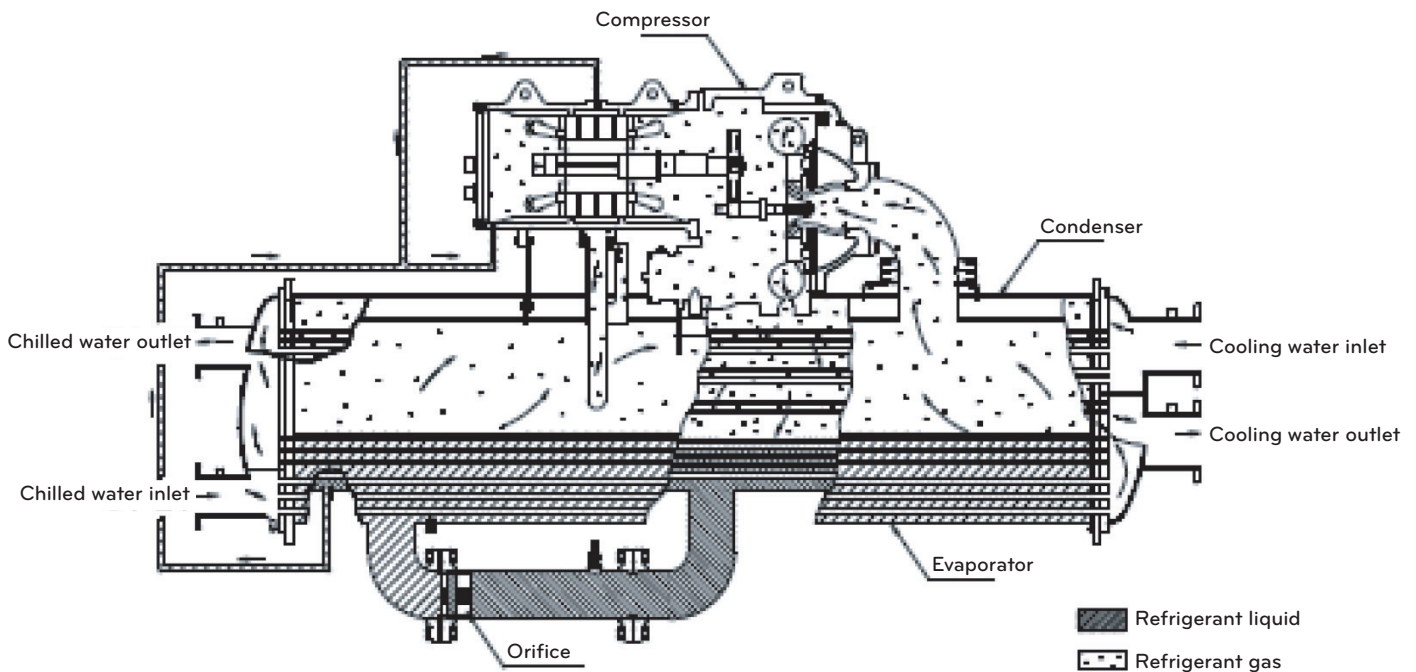

Fig 4. Single stage centrifugal chiller

3-2. Main components of the two stage centrifugal chiller

Compressor

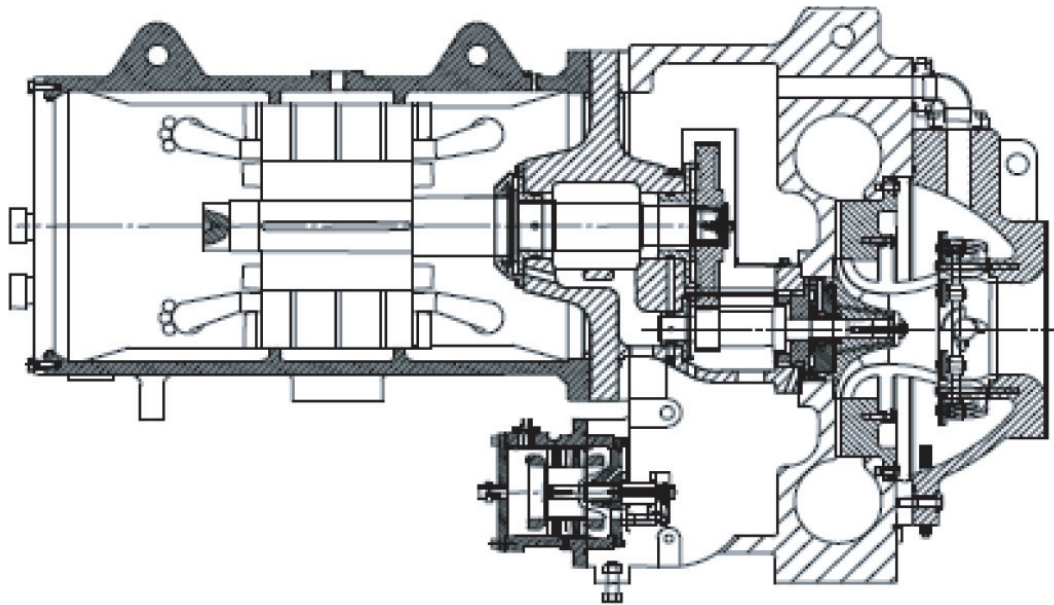

Fig 5. Hermetic single stage high-speed compressor

*The single stage turbo chiller compressor is composed of an impeller, bearing, diffuser, capacity control device and high-speed gear. The low temperature and low pressured gas taken from the evaporator, goes through impeller, dif-fuser and is finally discharged to the condenser as high temperature high pressure gas.

The characteristics of the main components are as follows.

1. Impeller

- The vane of impeller designed aerodynamically based on the 3D fluid analysis, guarantees the reliability in any operational condition.
- To minimize vibration, the impeller takes on the dynamic balancing work. It also guarantees the overall reliability of the impellers by taking the strength test, hardness test, and non-destructive test.

2. Bearings

- Bearings are composed of a bearing in the motor axis, radial bearings and thrust bearings on the impeller axis.
- Bearings are made of white metal to achieve persistence and corrosion resistance. It is designed to be used safely avoiding metal to metal contact during operation as the lubricating structure of Figure 8.
- To increase the reliability of the journal bearings, Offset type and 3-Lobe type bearings are applied.

3. Capacity control device

- It adjusts the refrigerant amount taken through the compressor inlet to adjust the capacity of the chiller, and it adjusts the opening of the vanes using the external actuator.
- The amount of refrigerant taken in is adjusted according to the set of chilled water outlet temperature.

Heat exchanger

Heat exchanger of single stage centrifugal chiller is composed of two shell type for easy separation into evaporator and condenser. The tubes are arranged so as to maximize the heat exchanging ability. It is also designed so that the refrigerant can be spread evenly on all tubes for the sake of surge prevention and the COP decrease in part load operation. Efficiency increasing purpose sub cooler is adopted for the subcool of the condensed refrigerant. A relief valve for an abnormal situation is at the upper part of the heat exchanger.

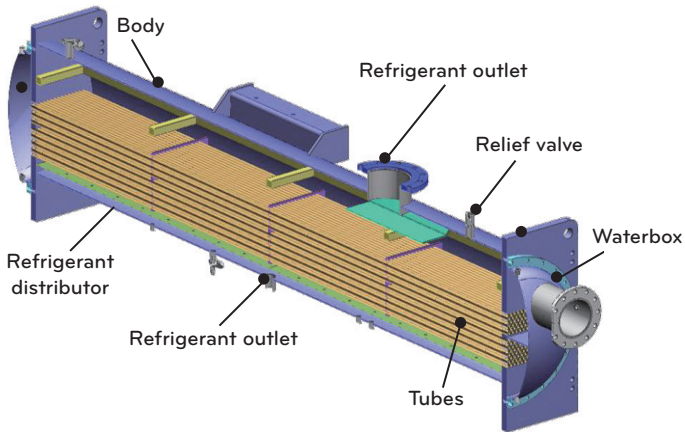

Figure 6. Evaporator

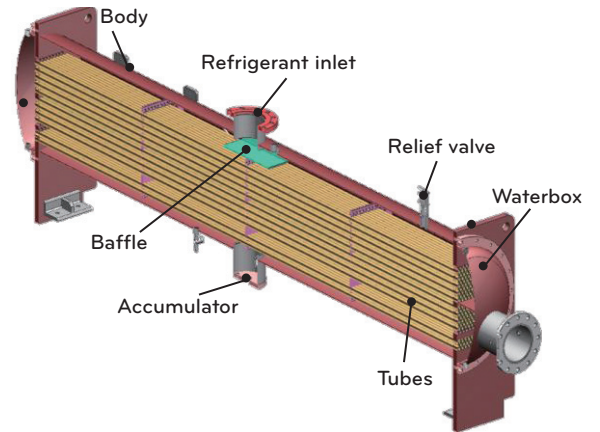

Figure 7. Condenser

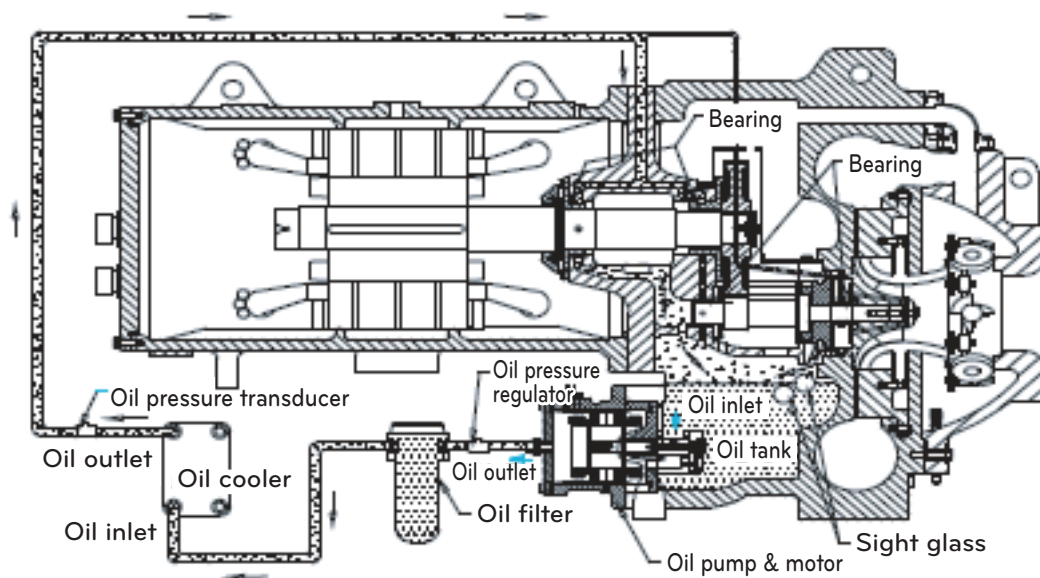

Figure 9. Lubrication cycle

Introduction

The discharged lubricating oil by the oil pump enters the oil filter to get rid of any unnecessary foreign substance. This oil becomes cooled to the temperature appropriate for operation condition after through the oil cooler, part of it directly enters gear and high speed side bearings, and the remainder directly enters motor shaft bearings. After the process, it will be drained into the oil tank. The above figure shows the lubrication system of single stage compression type.

Lubrication cycle

Lubricating oil is forwarded through the manual oil charge valve to the Lubrication System.

Oil level can be detected through a sight glass on the oil tank. During the operation, the level should be able to be detected at least from one of them.

The temperature of the oil tank is indicated on the control panel and its temperature range is 30~65 °C while operating. What the oil pump does is to transfer the oil from the oil tank to the system and the adequate pressure different would be 1.0 kg/cm² that is maintained by the oil pressure controller. The differential pressure can be seen on the control panel pressure gauge display by the differential pressure between oil tank and oil pump.

The oil pump also helps to send the oil to the oil filter. A valve is installed at the oil filter so that no need to drain the whole oil when replacing the filter only.

After the oil is sent to the oil cooler it is cooled by the refrigerant flowing from the condenser. The refrigerant cools the oil at the temperature between 40~60 °C.

A part of the oil flows through the thrust bearing and gear spray, whereas the rest lubricates the motor shaft bearings and the radial bearings. The oil temperature in the oil tank is measured by temperature sensor and displayed.

The timer automatically activates the oil pump for 120~180 seconds to maintain a constant pressure first before starting compressor. After the system has been shut down, 300~600 seconds lubricating is taken place after the compressor is stopped.

Oil reclaim system

Oil reclaim system provides the system to reclaim the oil from the heat exchanger and let it come back to the oil tank. Normally, it is reclaimed at the evaporator, and the vane housing. Refrigerant which came back into the oil tank will then be evaporated to the gas and flow through the DEMISTER line which is located at the upper part of the casing, and then it will be sent to the inlet of the compressor. Oil that is contained in the refrigerant is separated by the demister filter.

MAINTENANCE

Most of the lubrication related deficiencies in rotating parts of the chiller are because of the oil itself. If adequate viscosity, pressure and flow are not obtained, lubricating performance will decrease. Impure substances that are present in the oil also are a cause for the deficiencies.

Freon type refrigerant have chemical attraction with the oil. The viscosity changes according to the temperature and pressure of oil. We have designed the chiller with these problems into consideration.

An oil pump run by hermetic electro motor and a heater controlled by the controlling device are installed in the oil tank to prevent the trouble caused by the refrigerant inflow into the oil, decrease of the viscosity, damage of the pump caused by the cavitation (vaporizing of water and formation of bubbles as becoming partially low pressurized when water or flow at high speed) and the oil inflow into the refrigerant by forming. For these reasons the oil tank is maintained at a high temperature.

The reason to start the oil pump for certain while before the startup of the chiller, is to prevent the compressor's initial unsteady operation because the left over oil in bearings or in the oil line may contain significant amount of refrigerant flow in during the stoppage.

After the chiller has been shut down, oil pump will be operated until the compressor is totally stopped since the compressor rotates due to the internal force.

The only action that can be taken to prevent lubrication inferiority caused by blazing of the oil is replacing the oil itself. Thus when it is time for cooling operation, make sure that you do the oil replacing adequately.

Safety devices

For the sake of safe operation and the protection of the chiller, safety devices are ready as the next table.

No.	Safety Devices	Installation Location	Measurement Item	Description	Quantity		
1	Chilled Water Temperature Low	Chilled water inlet nozzle	Chilled water inlet temperature	Chiller stops operation if the chilled water outlet temperature below 3°C to prevent freezing of the chilled water. Do not change this set value.	1		
2	Evaporator Pressure Low (Temperature Low)	Evaporator shell	Vaporizing pressure (temp.)	If the pressure inside of evaporator reaches below of the following table, then the chiller stops operation. <table border="1" style="width: 100%; border-collapse: collapse;"> <tr> <td style="width: 60%;">Standard setting value</td> <td style="width: 40%; text-align: center;">1.95kg/cm²</td> </tr> </table>	Standard setting value	1.95kg/cm ²	1
Standard setting value	1.95kg/cm ²						
3	Condenser Pressure High (Temperature High)	Condenser shell	Condensing pressure (temperature)	If the pressure inside of condenser reaches above of the following table, then the chiller stops operation. <table border="1" style="width: 100%; border-collapse: collapse;"> <tr> <td style="width: 60%;">Standard setting value</td> <td style="width: 40%; text-align: center;">10.00kg/cm²</td> </tr> </table>	Standard setting value	10.00kg/cm ²	1
Standard setting value	10.00kg/cm ²						
4	Motor Temperature High	Motor coil	Motor coil temperature	To prevent the motor of the compressor, temperature sensors were installed on each phase of coil and when the temperature exceeds 90°C, the chiller stops operation.	3		
5	Compressor Temperature High	Compressor outlet	Compressor discharge temperature	If the discharging gas temperature of the compressor exceeds over 70°C, the chiller stops operation.	1		
6	Bearing Temperature High	Thrust bearing	Bearing temperature	Temperature sensor is installed on the thrust bearing that holds the impeller's thrust. Chiller will stop operation if the temperature exceeds 85°C.	1		
7	Oil Differential Pressure Low	Oil tank, oil pump outlet	Differential pressure of supplied and intake oil pressure	If the differential pressure between the oil pressure supplied to the bearing and the oil pressure in the oil tank is below 1.0 kg/cm ² , the chiller will stop the operation.	1		
8	Oil Temperature High	Oil tank	Oil temperature inside of oil tank	The chiller will stop if the oil temperature in the oil tank is above 74°C.	1		
9	Oil Temperature Low	Oil tank	Oil temperature inside of oil tank	The temperature should be over 30°C as an initial operating condition to enable the chiller to operate.	1		
10	Chilled Water Pump Abnormal	Chilled water header	Chilled water head loss	The chiller will stop if the head loss of the chilled water flow passing through the evaporator tubes decreases so much that the loss head becomes lower than the standard.	1		
11	Cooling Water Pump Abnormal	Cooling water header	Cooling water head loss	The chiller will stop if the head loss of the cooling water flow passing through the condenser tubes decreases so much that the loss head becomes lower than the standard.	1		
12	Current Limiting Function	Control panel	Current	It is a controlling function of Motor Amps that can be set freely in the range of 40 ~ 100% to adjust the current load to the motor of compressor.	1		
13	Moisture Indicator	Refrigerant supply pipe	Moisture in the refrigerant	The moisture indicator changes the color depending on the amount of moisture in the refrigerant. When there is no moisture it will be green, but if not it will be yellow. It is the time to change into a new filter if you can see the yellow color.	1		

No.	Item	Installation Location	Measurement Item	Description	Quantity
14	Relief Valve	Evaporator & condenser shell	Relief valves	To prevent the accident by unexpected fire, and so on which can cause pressure increase in the chiller, the relief valve will be operated and exhaust the refrigerant into the air if the pressure exceeds more than the standard. If the chiller is used in a closed environment, please install a pipe that starts from the relief valve to the outer air.	1
15	Vane Full Close Interlock	Vane motor	Operability of temperature sensors	To minimize the starting current, it is a function to enable the compressor to operate only after full close of the guide vane installed at the inlet of the impeller.	1
16	Temperature Sensor Abnormal	6 locations including chilled water nozzle	Each temperature sensor	It alarms when temperature sensor is not connected or due to the sensor's own flaw.	1
17	Pressure Sensor Abnormal	4 locations including Evaporator shell	Each pressure sensor	It alarms when pressure sensor is not connected or due to the sensor's own flaw.	1
18	Overload relay	Control panel	Current	If overload is imposed on compressor motor or oil pump motor, it stops the motor.	1
19	Hot Gas Bypass Valve	Evaporator shell, Condenser shell	Guide vane / hot gas valve opening	It prevents frequent start ups at low load, and hot gas bypass valve opens proportionally when vane becomes 30% or lower. At this time, hot refrigerant gas of condenser goes to evaporator and makes certain chiller load to prevent surge and to prevent frequent startup stop of the chiller.	1

Table 3. Safety devices

4. CONTROL SYSTEM

4-1. Components and Major Parts of the Control Panel

HMI

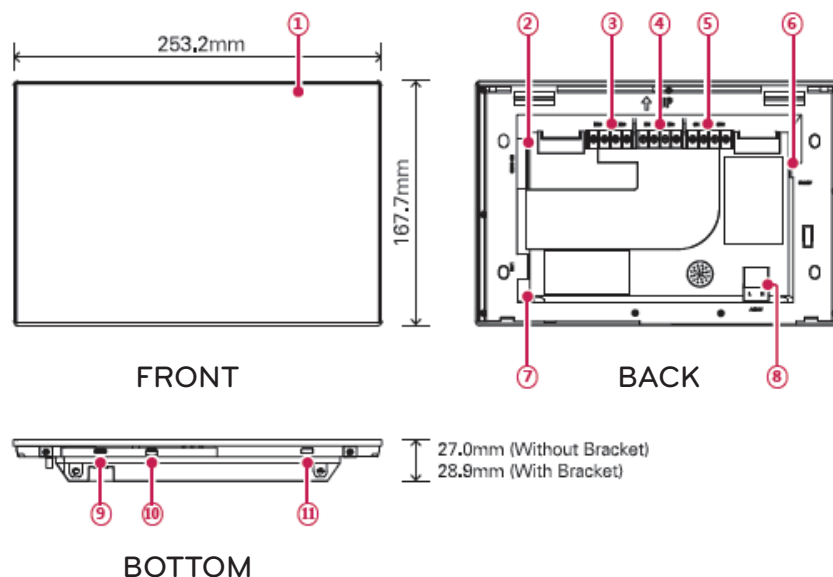

Figure 10. HMI Components

No.	Item	Description
①	Touch screen	<ul style="list-style-type: none"> • 10.2 inch LCD control panel • AC Smart Premium control and display various information
②	SD memory slot (for services)	SD card memory slot for S/W upgrades
③	DO port	2CH DO port
④	DI port	2CH DI port
⑤	485 port	2CH 485 port
⑥	DC 12V input port	DC 12V power input port
⑦	LAN port	LAN Cable connection port for Ethernet connection (Support 100Mbps/10Mbps)
⑧	AC 24V input port	AC 24V power input port
⑨	Micro USB port	Support port USB 2.0 for USB memory Stick connection
⑩	Mini USB port (for services)	PC connection power for S/W upgrades
⑪	Power ON/OFF	<ul style="list-style-type: none"> • Control AC Smart Premium LCD backlight for pressing less than 10 seconds • Reset AC Smart Premium system for pressing more than 10 seconds • LCD for not using AC Smart Premium for a long period • It is recommended to turn off when AC Smart Premium is not used for a long time so that the lifespan of LCD backlight could be extended.

Table 4. HMI Component Names and Functions

MASTER/SLAVE

The Master board and Slave board has the same hardware. They are used as Master or Slave by DIP switch settings. (SW4 OFF : Master, ON : Slave)

Analog input/output and digital input/output consist of RS232 and RS485 communication connectors for the user's convenience.

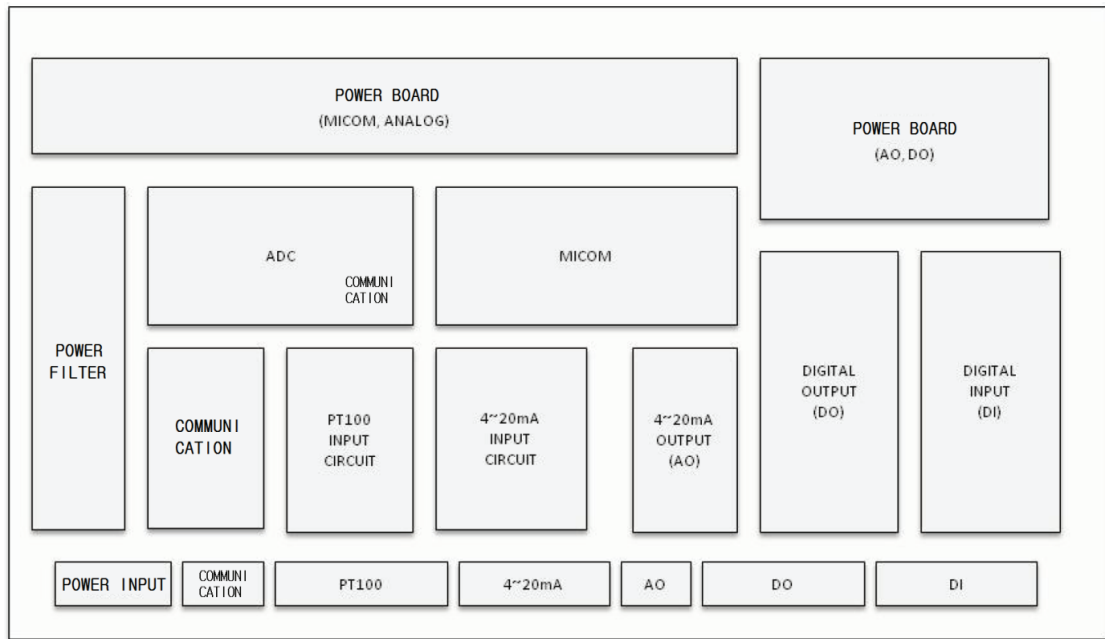
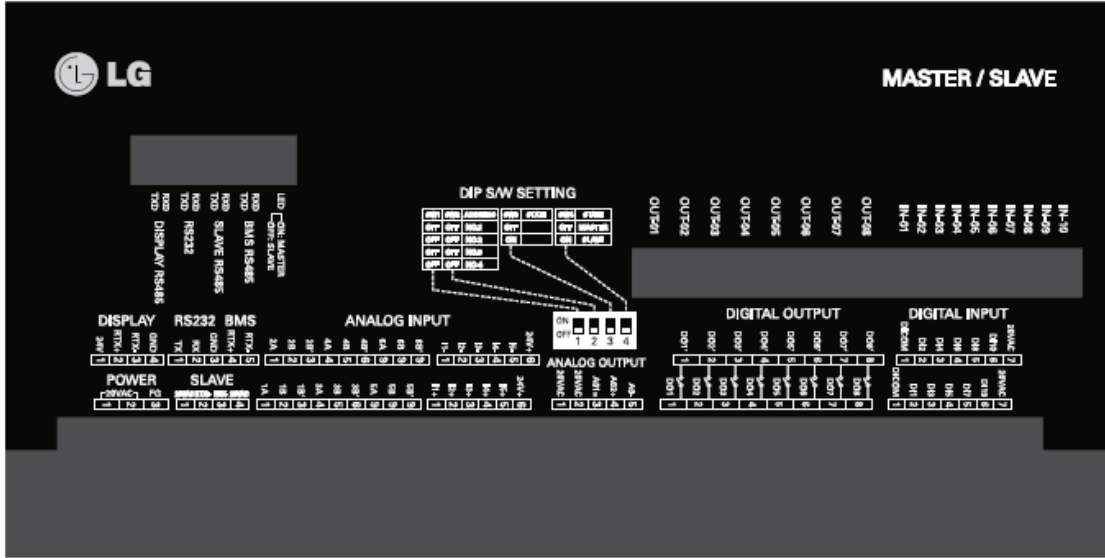

Figure 11. Master/Slave Board Internal Diagram

Control System Block Diagram

The Master, Slave, HMI and Relay boards communicate in the RS485 communication method, and one Master/Slave board consists of the analog input (12 channels for temperature, 10 channels for current), analog output (4 channels for current), digital input (20 channels) and digital output (16 channels).
 The Relay board is responsible for controlling the guide vane and diffuser vane.

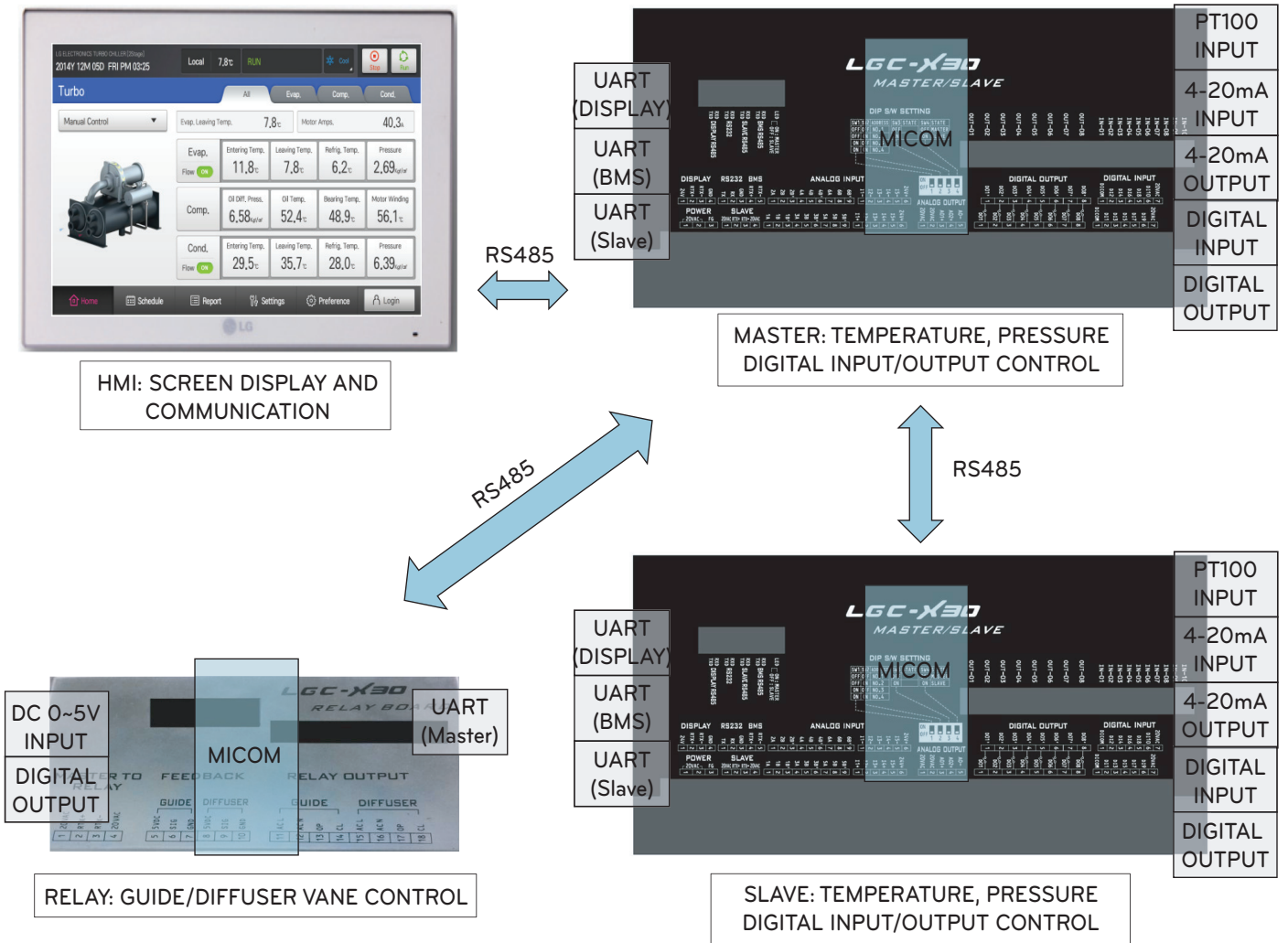

Figure 12. Controller Block Diagram

Other control parts

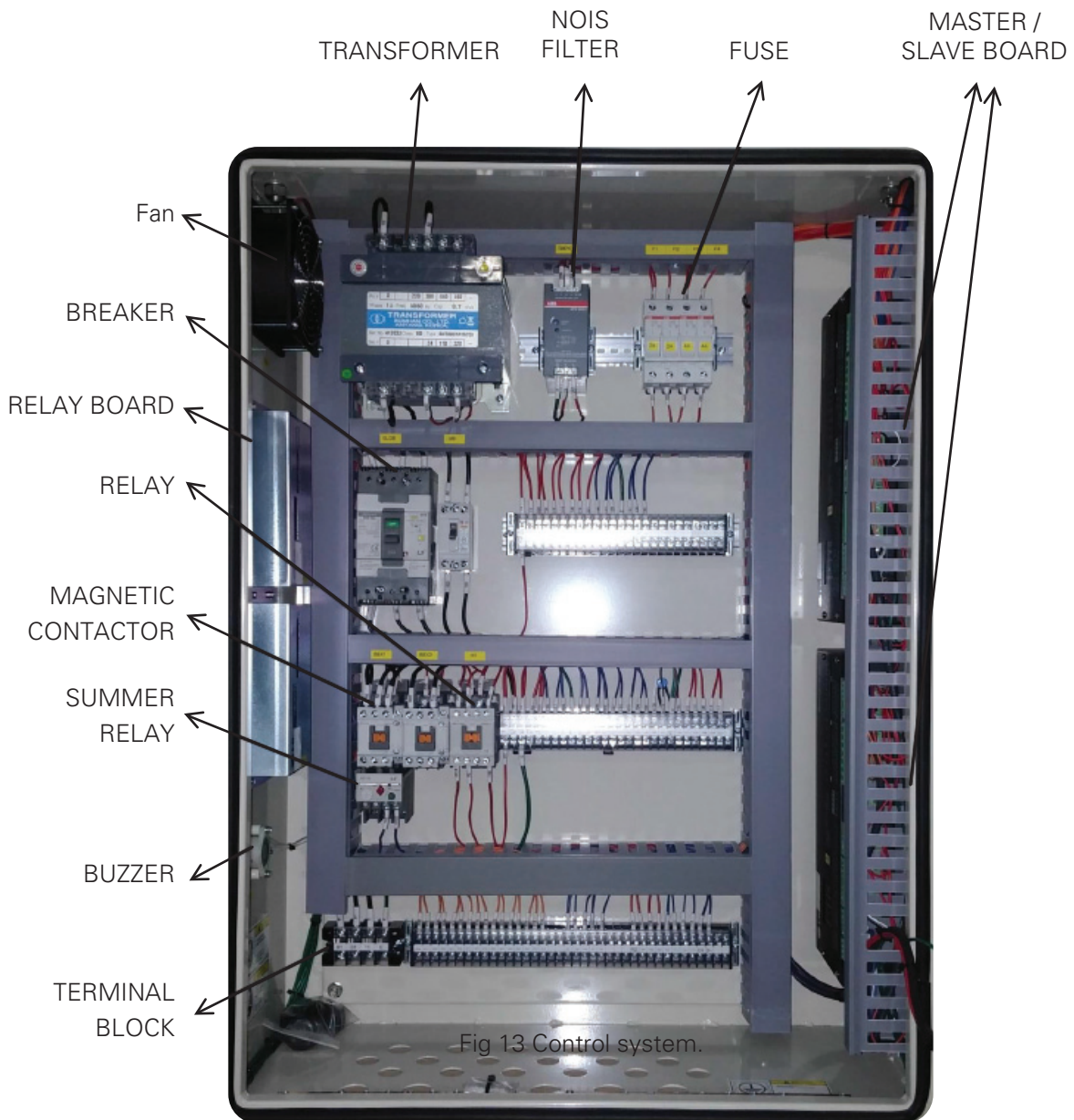

Figure 13. Control System

* Please refer to the approved diagram for details as the arrangement shown above may vary by model and change for design improvements and the user's convenience.

Option Parts Related to Control

BACnet Converter

Our controller basically supports Modbus communication protocol.

If the higher communication protocol is BACnet, the protocol should be converted by applying a separate BACnet.

A communication converter can only be attached inside the control board.

Refer to the table shown below for meanings and explanations for each lamp.

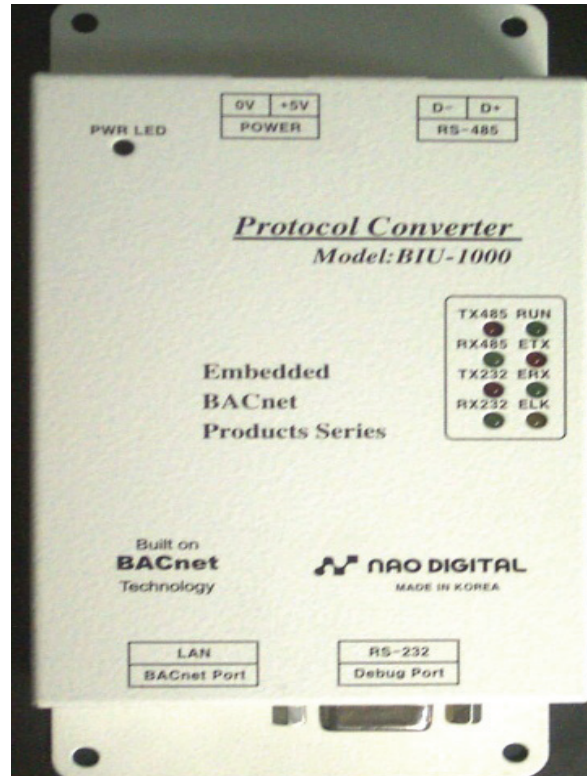

Figure 14. Converter

LED name	State	Explanation
TX485 RX485	Flicker	Communication with the MYCOM works normally
	Off	Error, check communication lines
TX232 RX232	Flicker	Communication with BACnet works normally
	Off	Error, check communication lines
RUN	Flicker every second	Board works normally after completing a Power-On test
	Maintain On/Off status	Error. Press reset button, or cut and resupply the power
ETX ERX ELK	Ethernet Line status LED	ELK is always on when LAN cables are connected, ERX is on when receiving data and ETX flickers when transmitting data

Table 5. LED Status Display

4-2. Components and Major Parts of the Starter Panel

Starter

Starter is an electric panel to protect and to start the motor of the Turbo Chiller compressor and has protection function from the short-circuit current and overcurrent.

This has the effect of reducing electric capacity of services by lowering the starting current when operating the motor.

Refer to the drawing supplied with the product for an arrangement of the starter, as the starter is arranged in various ways based on starting methods, high/low pressure power, options, etc.

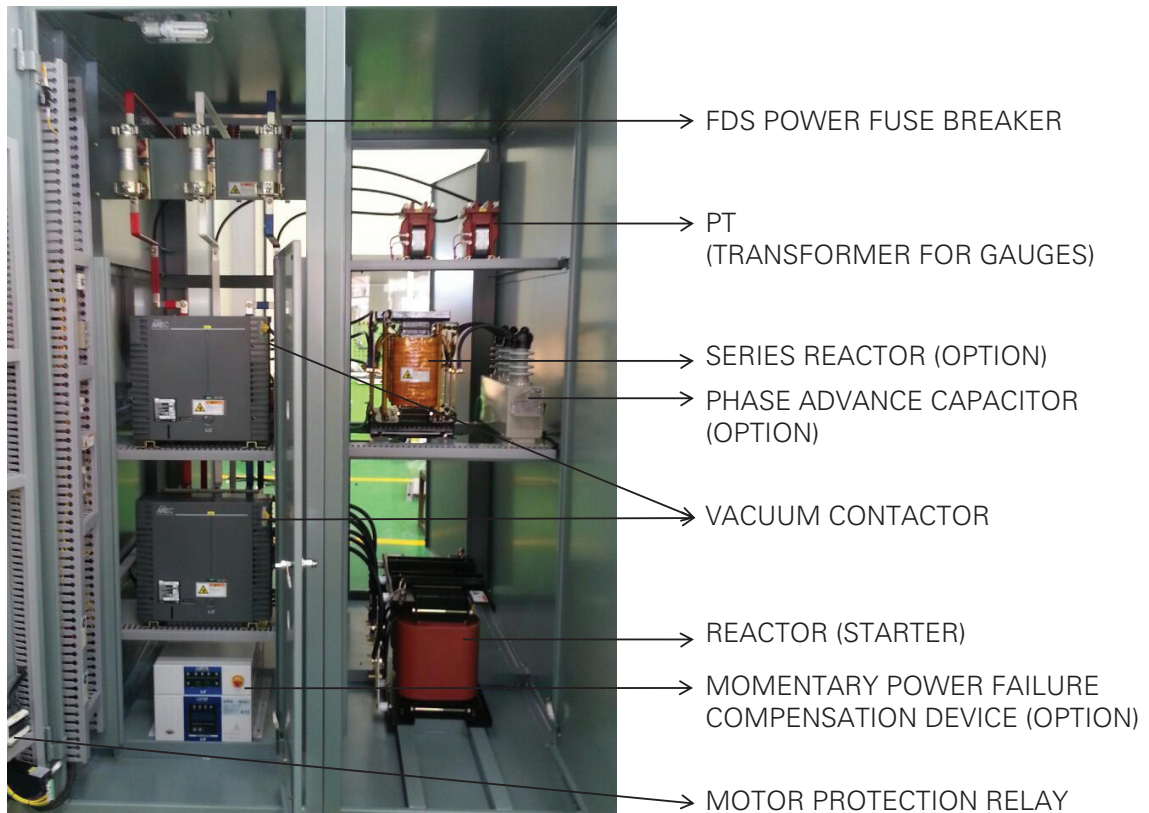

Figure 15. 6600V Reactor Starter Method

* Please refer to the approved diagram for details as the arrangement shown above may vary by model and change for design improvements and the user's convenience.

4-3. Control Parts Attached on the Product

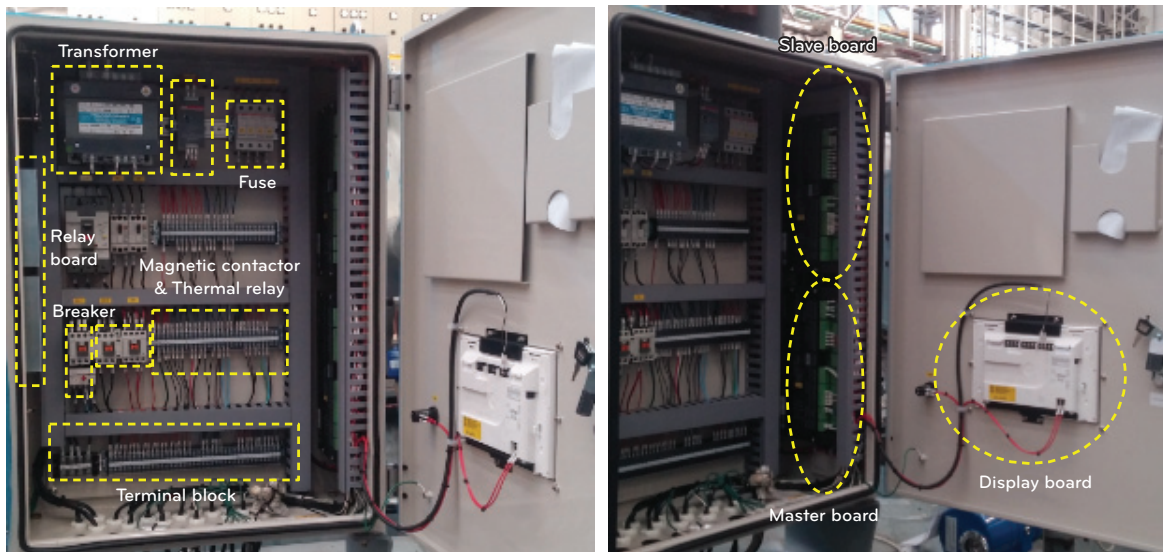

Figure 16. Control Board

4-4. Basic Control Algorithm

The algorithm managed to implement the best control by minimizing Under-shoot and Over-shoot when automatically/manually converting time to approach a goal, steady status error, initial operation and vane adjustment compared to the previous method by applying unique P (proportion), I (integration) and D (differentiation) algorithms to the cold water temperature control.

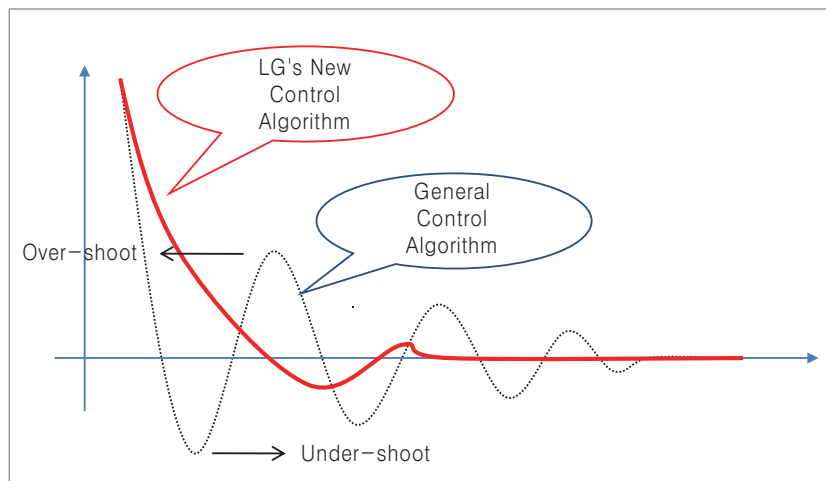

Figure 17. P.I.D Operating Control

- Soft loading
 - Approach a control goal by soft operation
 - Resolved unnecessary emergency stop due to rapid guide vane opening which occur in operating
- Advanced control
 - High precision control is realized by applying the far advance algorithm compared with existing PID control methods.
 - Prevent temperature Cycling phenomenon due to Over-shoot/Under-shoot when converting from manual to automatic mode.
 - Intensive Safety Control
 - Minimized unnecessary stops for abnormality of the Chiller by implementing preventive control before the Chiller starts to stop for abnormality

4-5. BMS Support Function

The basic communication of the Turbo Chiller is Modbus protocol, and it is compatible with higher communication methods.

Communication Protocol Support

- Communication method
 - Standard: RS-485, Ethernet (option)
- Protocol
 - Standard: MODBUS
 - Option: BACnet, TCP/IP

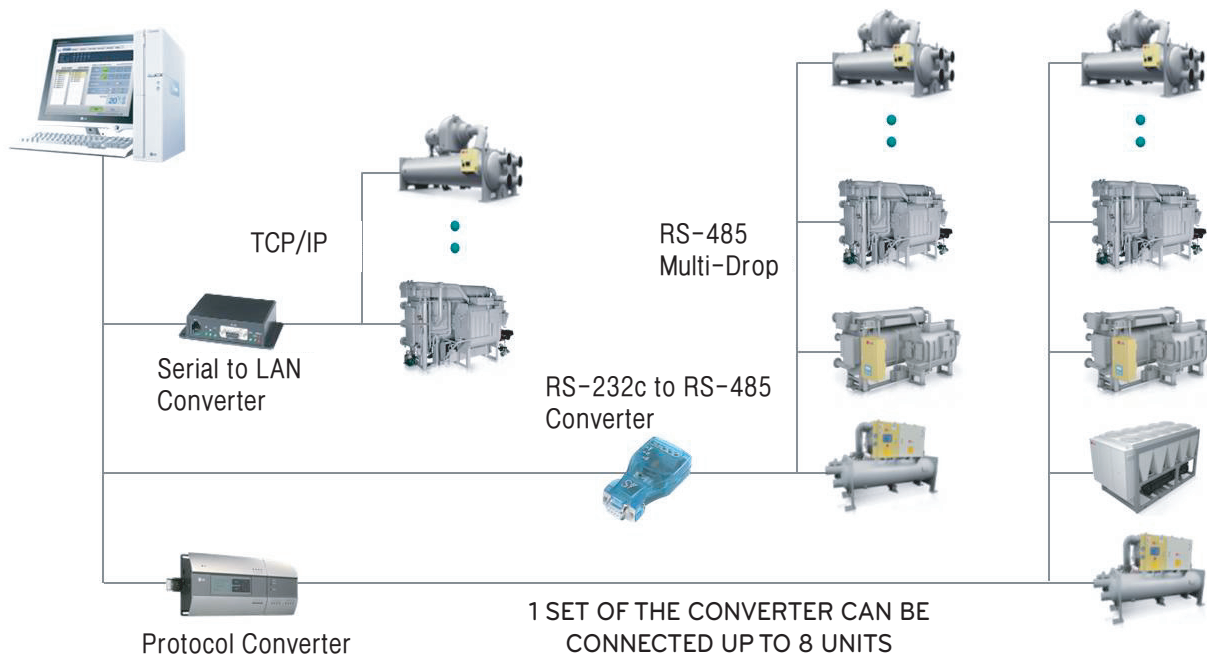

Figure 18. BMS Detail Drawing

4-6. Remote Control Signal and Status Signal Connection

How to connect remote start/stop signals

Two wire consecutive signals for a point of contact of zero voltage

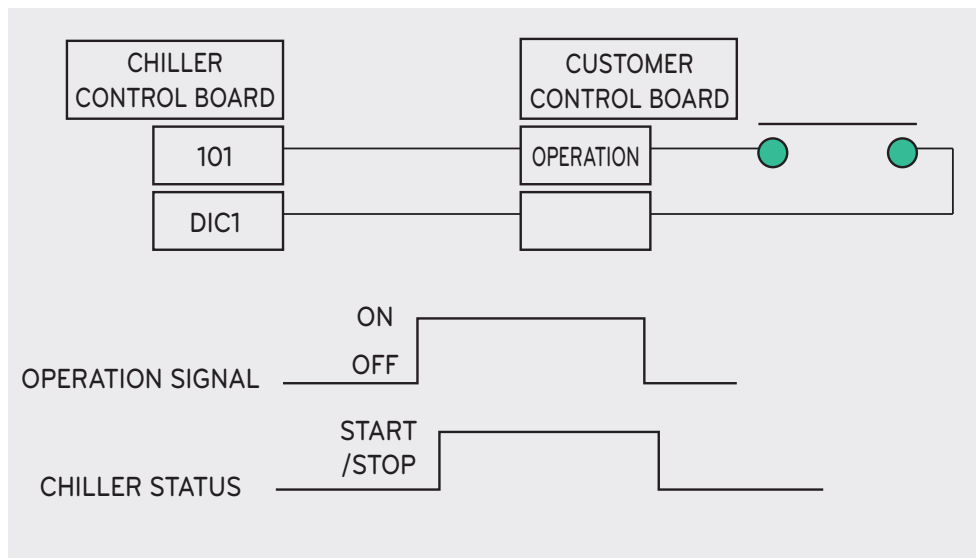

Figure 19. Control Signal

* Minimum time to maintain start/stop pulse: maintain for at least 2 seconds.

4-7. Power Panel and Interface Signal

Signal name	Signal type	Signal meaning	Notes
Cold water pump interlock Coolant pump interlock	Input (contact of zero voltage)	The interlock checks the operation of the electric contactor for pump operation. If there is no signal when operating, the Chiller does not start. No input even when operating may cause abnormalities.	Detect status of a contact by outputting DC24V. Make sure to avoid resistance of contact above 100Ω. (Conduit process should not be carried out with other power lines.)
Cold water pump start/stop Coolant pump start/stop Cooling tower fan start/stop	Output (contact of zero voltage)	This is the start/stop signal of the pump or fan. Access when operating by linking with start/stop signals from the Chiller.	Use it at AC250V 0.1A (resistance load)

4-8. Central Monitoring Panel and Interface Signal

Signal name	Signal type	Signal meaning	Notes
Check motor operation Contact for signal	Output (contact of zero voltage)	ON when inputting operational signal OFF when inputting stop signal	Use it at AC250V 0.1A (resistance load)
Contact for start/stop display	Output (contact of zero voltage)	ON when operating the Chiller OFF when stop operating the Chiller	
Contact for abnormality display	Output (contact of zero voltage)	ON when the Chiller has a defect	
For remote operation display	Output (contact of zero voltage)	ON when remote operation mode is selected	
Contact for warning display	Output (contact of zero voltage)	ON when alarm is activated	

4-9. Start and Control Order

Turbo Chiller Signal Flow Graph

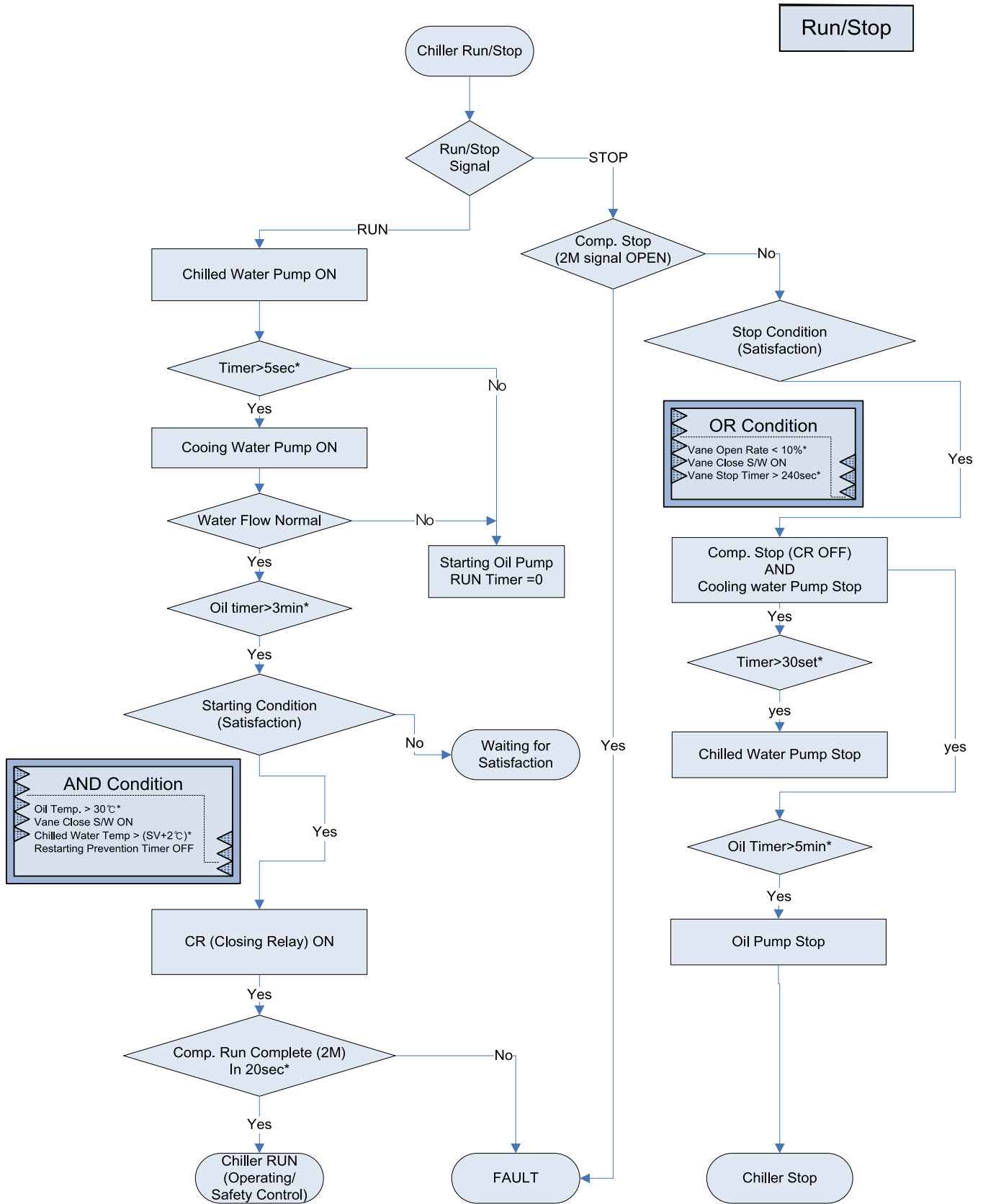
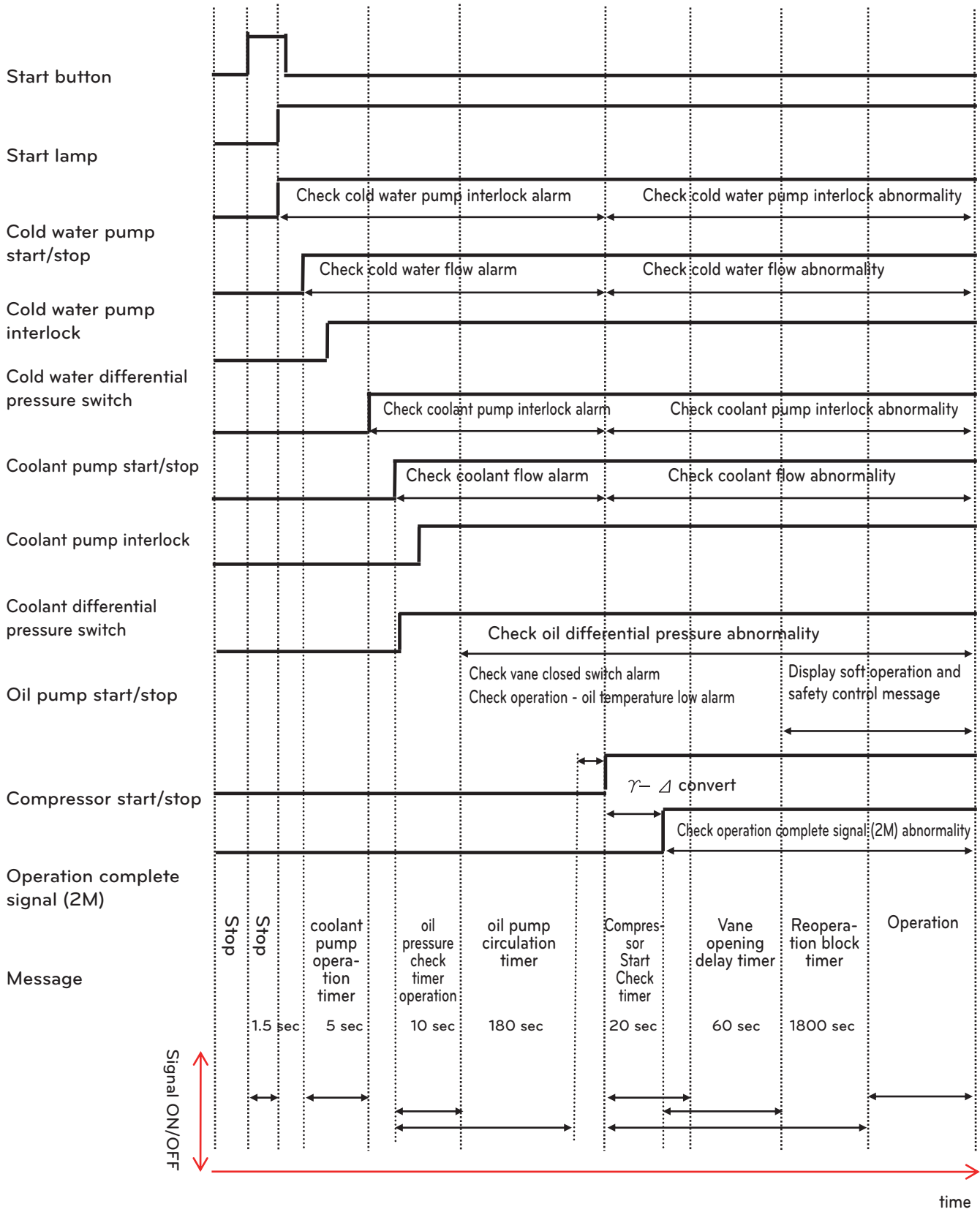

Figure 20. Turbo Chiller Signal Flow Graph

Turbo Timing Sequence - Run



Turbo Timing Sequence - Stop

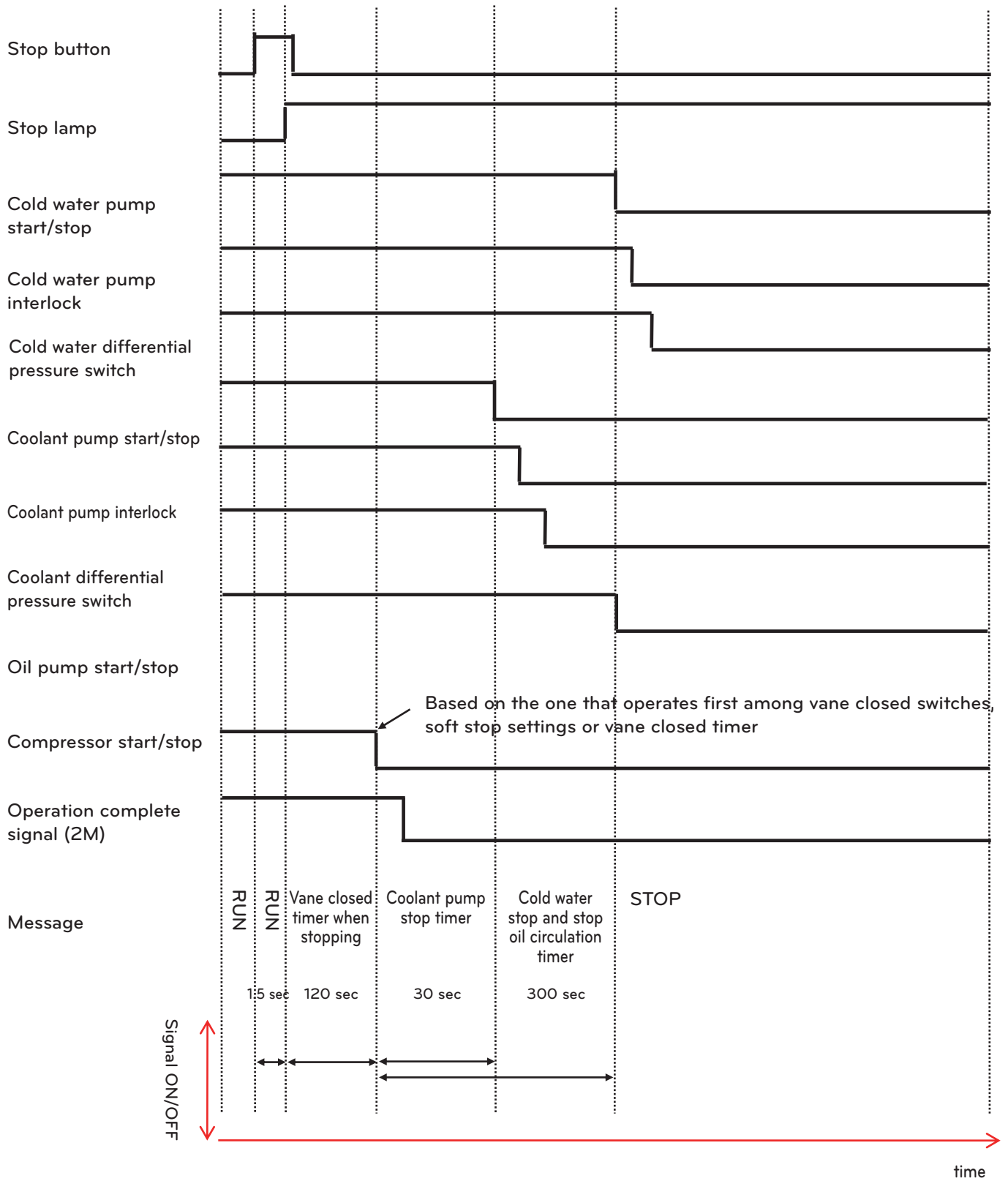

Figure 21. Timing Sequence

4-10. Product Protection Function

Category	Description	Cause	Action	Status
Sensor	Sensor abnormality such as temperature, pressure and current, etc.	Detected temperature, pressure and current sensor abnormality	The Chiller stops	Abnormal
Interlock	Cold water pump interlock abnormality	Detected pump interlock abnormality when operating	The Chiller stops	Abnormal
	Coolant pump interlock abnormality	Detected pump interlock abnormality when operating	The Chiller stops	Abnormal
	Low cold water flow abnormality	Detected flow interlock abnormality when operating	The Chiller stops	Abnormal
	Low cold coolant flow abnormality	Detected flow interlock abnormality when operating	The Chiller stops	Abnormal
Temperature & Pressure	High oil temperature abnormality control	Detected high oil temperature	The Chiller stops	Abnormal
	High condenser pressure abnormality	Detected high condenser pressure	The Chiller stops	Abnormal
	Low evaporator pressure abnormality	Detected low evaporator pressure	The Chiller stops	Abnormal
	Evaporator refrigerant block abnormality	Detected low evaporator refrigerant temperature	The Chiller stops	Abnormal
	high Compressor outlet temperature abnormality	Detected high condenser outlet temperature	The Chiller stops	Abnormal
	high Motor winding temperature abnormality	Detected high motor winding temperature	The Chiller stops	Abnormal
	high Bearing temperature abnormality	Detected high bearing temperature	The Chiller stops	Abnormal
	low Cold water temperature abnormality	Detected low cold water outlet temperature	The Chiller stops	Abnormal
Surging	Compressor surge current abnormality	Detected compressor surge current	The Chiller stops	Abnormal
Voltage	Low voltage abnormality	Detected low compressor motor voltage	The Chiller stops	Abnormal

Category	Description	Cause	Action	Status
Block control	Block low oil run	Oil temperature \leq operation oil Low temperature setting value	Display low oil temperature block control caution message	Caution
	Block low voltage	The guide closes the vane when a compressor motor voltage goes below low voltage block setting $-(100\text{-setting})/2$.	Display low voltage block control caution message	Caution
	Block high condenser	The guide vane closes when a condenser pressure goes above high pressure block setting $+ (100\text{-setting})/2$.	Display high condenser pressure block control caution message	Caution
	Block low evaporator pressure	The guide vane closes when an evaporator pressure goes below low pressure block setting $-(100\text{-setting})/2$.	Display low condenser pressure block control caution message	Caution
	Block low evaporator refrigerant temperature	The guide vane closes when an evaporator temperature goes below low temperature block setting $-(100\text{-setting})/2$.	Display low evaporator refrigerant temperature block control caution message	Caution
	Block high compressor outlet temperature	The guide vane closes when a compressor outlet temperature goes above high temperature block setting $-(100\text{-setting})/2$.	Display high compressor outlet temperature block control caution message	Caution
	Block high bearing temperature	The guide vane closes when a bearing temperature goes above high temperature block setting $+ (100\text{-setting})/2$.	Display high bearing temperature block control caution message	Caution
	Low cold water temperature block control	The guide vane closes when a cold water temperature goes below low temperature block setting $-(100\text{-setting})/2$.	Display low cold water outlet temperature block caution message	Caution
	Compressor surge current block	The guide vane closes when current goes above a setting value for more than the setting (setting number/3) within setting time.	Display compressor surge current block control caution message	Caution
	Motor overcurrent block control	The guide vane closes when a compressor motor current reaches setting*105% to make the current go below the setting.	Display compressor motor overcurrent block control caution message	Caution
	High motor winding temperature block	The guide vane closes when a motor winding temperature goes above high temperature block setting $+ (100\text{-setting})/2$.	Display high motor winding temperature block control caution message	Caution
	Condensing block control	1. The refrigerant gets condensed in oil 2. Viscosity of oil is low	Display condense block control	Caution (Operation unavailable)

Category	Description	Cause	Action	Status
Switch contact	High motor winding temperature contact opens	Coil temperature input contact opens	The Chiller stops	Abnormal
	Low evaporator refrigerant temperature contact closes	Low evaporator refrigerant temperature contact closes	The Chiller stops	Abnormal
	Oil pump overcurrent contact closes	Thermal type overcurrent relay contact attached on the oil pump power line closes	The Chiller stops	Abnormal
	High bearing temperature contact closes	High bearing temperature contact closes	The Chiller stops	Abnormal
	High condenser pressure contact closes	High condenser pressure contact closes	The Chiller stops	Abnormal
	Failure to operate	No input signal for compressor operation complete	The Chiller stops	Abnormal
	Delta contactor opens when operating	Starter contactor opens when operating	The Chiller stops	Abnormal
	Starter abnormality contact closes	Starter abnormality input contact closes	The Chiller stops	Abnormal
	Compressor motor power contact opens	Compressor power contact opens when operating	The Chiller stops	Abnormal
	Low oil pump pressure	Low oil pump pressure contact closes	The Chiller stops	Abnormal

Table 6. Protection Logic

4-11. Checklists before inspection

- 1) Thorough preparation
Check emergency treatment method, cleanness of surroundings, and safety of facilities and machines.
- 2) Review based on the circuit diagram
When the power system is supplied through other systems, check various power sources, if the 1st breaker is supplying the power or not and installation status of the ground wire.
- 3) Contact
Check if you can closely and clearly communicate with relevant organizations.
- 4) Check zero voltage status and safety measures
Review lists shown below for safety when reviewing the main circuit.
 - a) Make the main circuit zero voltage by opening related breaker and disconnecting switch.
 - b) Check zero voltage stage with an electroscope and ground at needed spots.
 - c) Take out circuit breakers to make short a circuit and attach display "inspecting."
 - d) Adjust disconnecting switches after cutting the power.
 - e) Especially when the power is supplied with incoming/distributing panel from a consumer, automatic control, or MCC board, take measures in (c) and (d) above for those switches.
- 5) Warnings about current and voltage
Implement grounding after discharging the remaining current when inspecting parts of the condenser and cable.
- 6) Prevention of malfunction
Attach power cut and caution marks.
- 7) Prepare for protective tools for insulation
Wear protective tools for safety that match the rated voltage such as insulated gloves, safety helmets, insulated tall boots, safety apparel, etc.
- 8) Measures for invasion of mice and insects
Prepare measures to prevent mice, insects, snakes, etc. from entering the site.

4-12. Checklists after inspection

1) Final check list

- Check if a worker is inside the site.
- Check if demolition of temporary buildings constructed for inspection is not delayed.
- Check that bolts are tightened properly.
- Check if tools, etc. are left.
- Check if mice and insects, etc. did not invade.

2) Inspection history

Make sure to record main points of inspection and repair, failure status and dates when inspecting to utilize histories as reference for next inspection.



CAUTION

Set the routine inspection to check loading, operating hours, and operating environment, etc. of the operating machine.

As the inspection period suggested in this manual is routine inspection, establish inspection plans depending on the load of the machine and frequency of use.

Do not conduct insulation resistance tests on second transformers for the controller or control power.

Do not conduct insulation resistance tests on parts (sensors, switches, etc.) connected to the controller, etc.

4-13. General Checklist

Inspection	Inspection categories	Inspection items				Criteria
			Daily	1 year	2 years	
All	Ambient environment	Is there any dust? Is the ambient temperature and humidity adequate? Is there any abnormal vibration?				Refer to Chapter 1. Environmental conditions
	Equipment	Is there any vibration or noise?				No abnormality
Main circuit / Control circuit	Input voltage	Is the main circuit voltage normal? Is the main circuit voltage normal?				Refer to Chapter 1. Environment
	Insulation resistance test	Disconnect all power before testing insulation resistance. Insulation between the transformer 1st side and grounding bus-bar. When measuring the resistance, disassemble all grounding wires connected to grounding bus-bar.				*Low voltage (600Vac or less) DC 500V class mega, it shall be 5M Ω or more. *High voltage (exceeding 600Vac, 7000Vac) DC 1000V class mega, it shall be 30M Ω or more.
	Overheating	Is there any trace of overheating in each component?				No abnormality
	Fixed parts	Is there any missing fixed parts?				No abnormality
	Conductor/wire	Is there any contamination of conductor? Is there any damage in the wires?				No abnormality
	Terminal	Is there any damaged part?				No abnormality
	Relay /contactor	Is there any oscillation during operation? Is there any damage on the connector?				No abnormality
	Space heater	Is there any color change of the heater component in starter panel?				No abnormality
	Sensor & switch	Is there any disconnection or short circuit? Is there any damage in the contact part?				No abnormality
	Grounding	Is there any rust on the connection part? Is there any damage in the grounding conductor? Is there any noise in the grounding system? Note: Grounding resistance shall meet the requirements of the related codes and standards.				No abnormality
	Phase advance capacitor	Is the expansion under the limit?				No abnormality
	Cooling fan	Is there any abnormal noise? (Control Panel)				No abnormality
Control function	Safety function Is the safety function in normal operation? Is the start-up sequence normally carried out? Is the stop sequence normally carried out? Is the temp. regulation within the specification?				Normal control	
Display	Analog value	Is the displayed value correct?				No abnormality
	Indication Lamp	Is the indication lamp displayed with the normal brightness?				No abnormality

Table 7. General Checklists

5. HMI

5-1. Start HMI

1.1 Menu Structure

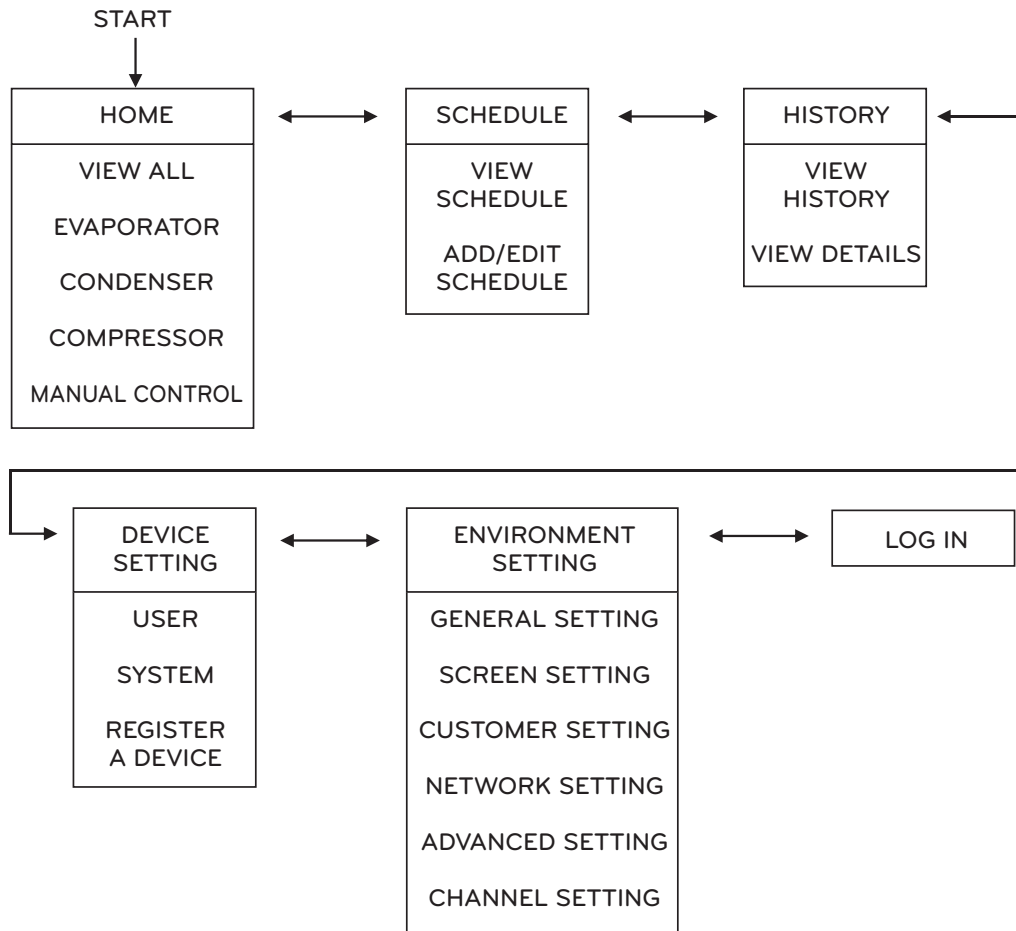

Figure 22. Menu Structure

1.2. How to Input Information

A touch keyboard appears at the bottom of the screen by touching the information input column. Enter information using the touch keyboard.

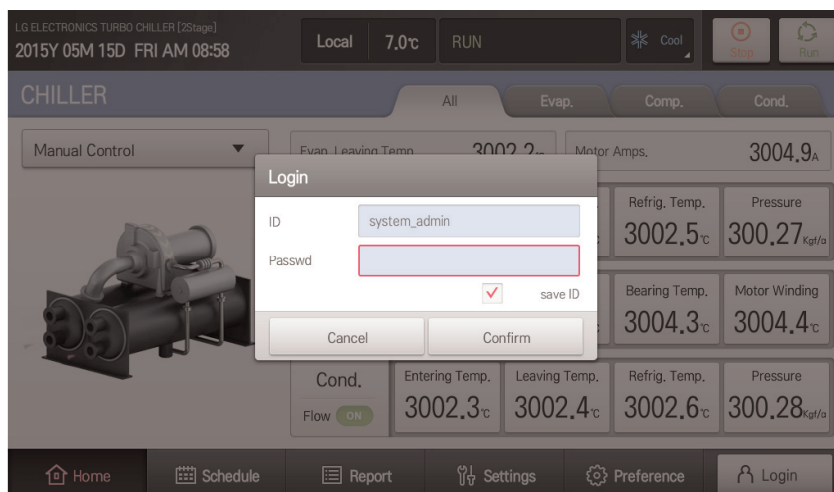

Figure 23. Login Screen

1.3. How to LOGIN

It is divided into LOGOUT/LOGIN (ADMINISTRATOR/INSTALLER).

General users other than the administrator and installer cannot access major setup items by categorizing accessible areas for each authority.

All setup items except operation stop can be accessed after login including operation start.

Function	LOG OUT	LOG IN (administration authority)	LOG IN (installer authority)
Top menu (stop operating)	○	○	○
Top menu (start operating)	X	○	○
Top menu (operation mode)	X	○	○
Schedule (add/edit/delete)	X	○	○
History (delete items)	X	X	○
Device setting (user)	X	○	○
Device setting (user → initialization of operating hours)	X	X	○
Device setting (system)	X	X	○
Device setting (device registration)	X	X	○
Environment setting (general setting)	X	○	○
Environment setting (screen setting)	X	○	○
Environment setting (customer setting)	X	○	○
Environment setting (network setting)	X	○	○
Environment setting (advance setting)	X	X	○
Environment setting (channel setting)	X	X	○

Table 8. LOGIN Policy

1.4. Top Menu

The top menu consists of date/time information, product information, control mode, temperature settings, operation status, warning message, operation mode and the operation control button.

When messages for abnormality appear, the disable warning button feature is additionally provided on the right side of operation status and warning message area.

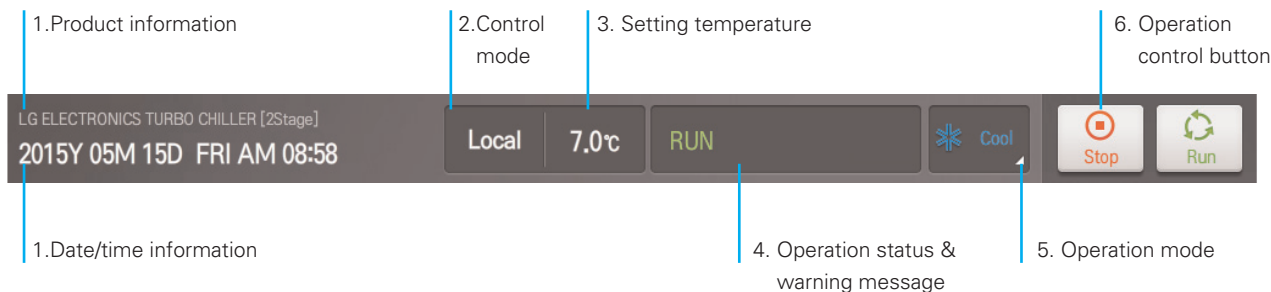

Figure 24. Top Menu

1. Date/hour/product information

- Display the connected product information (brand + product type + model no.).
- Display current date and time information in the order of date, day and time.

2. Control mode

- There are three control modes. Local Operation directly operates on site. Schedule Operation automatically operates the product according to a scheduled time. Remote Operation operates the product remotely. The control mode currently set is displayed on the screen.

3. Setting temperature

- Display the temperature setting of the evaporator outlet.

4. Operation status & warning message/Disable warning button

- Display the system operation status information and warning message.
- Display the warning message and Disable Warning button message by expanding to the control mode/temperature setting/operation mode area in case of abnormality.
- When a message appears, yellow represents warning and red represents abnormality.

5. Operation mode

- Display the currently set operation mode.

6. Operation control setting

- The Chiller starts operating when the start button is pressed, and the Chillers stops operating when the stop button is pressed.

1.5. Bottom Menu

The bottom menu consists of the main menu and the login button at the bottom of the screen.

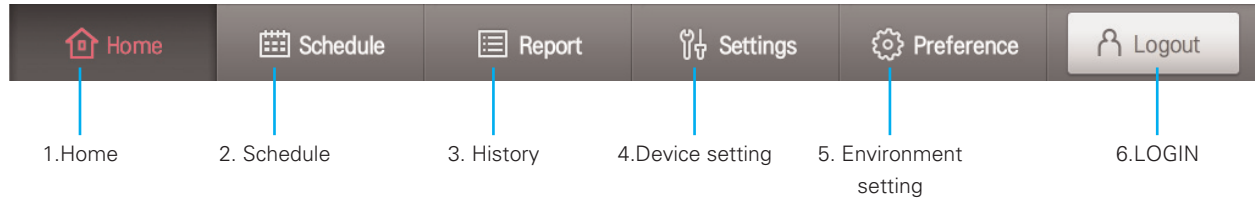

Figure 25. Bottom Menu

1. Home
Go to Home screen.
2. Schedule
Go to schedule screen.
3. History
Go to history screen.
4. Device setting
Go to user menu of device setting screen.
5. Environment setting
Go to language setting menu of the environment setting screen.
6. LOGIN/LOGOUT toggle button
Display LOGIN button when logged out.
Display LOGOUT button when logged in.
* Automatically log out when there is no control for 30 minutes after logging in.

5-2. Home Screen Composition

2.1. View All

This consists of the main menu and LOGIN buttons at the bottom of the screen.



Figure 26. View All

No.	Component	Description
1	Device name	Provides device names.
2	View all tab	This tab provides overall information about the Chiller, and it is the default when accessing the home screen for the first time.
3	Evaporator tab	Provides evaporator information screen when selected.
4	Compressor tab	Provides compressor information screen when selected.
5	Condenser tab	Provides condenser information screen when selected.
6	Manual control button	Provides manual control list.
7	Animation	Provides a current animation of the Chiller (R134a, 2Stage, R123).
8	Major information of the device	Provides evaporator leaving water temperature and motor current. Provides the same information when moving to other information tabs.
9	Evaporator	Provides evaporator entering water temperature/leaving water temperature/ refrigerant temperature/ pressure information.
10	Compressor	Provides compressor oil differential pressure/oil temperature/bearing temperature/motor winding information.
11	Condenser	Provides condenser entering water temperature/leaving water temperature/ refrigerant temperature/pressure information.
12	Operation mode	Provides different colors depending on an operation mode. Blue: cooling, orange: heating, ice manufacturing: blue-black, stop: gray.

Table 9. View All Items

2.2 Evaporator

Displays DATA related to the animation screen of the evaporator.



Figure 27. Evaporator

No.	Component	Description
1	Animation	Provides the evaporator animation.
2	Major information of the device	Displays evaporator leaving water temperature and motor current. Provides same information when moving to other information tabs.
3	Main information	Provides evaporator pump interlock/flow contact/outlet water setting temperature information.
4	Additional information	Displays evaporator entering water temperature/leaving water temperature/pressure/refrigerant temperature/LTD/ flow/ECO level/ECO calculation/ECO valve information.

Table 10. Evaporator Items

2.3. Compressor

Display data related to the compressor animation display.

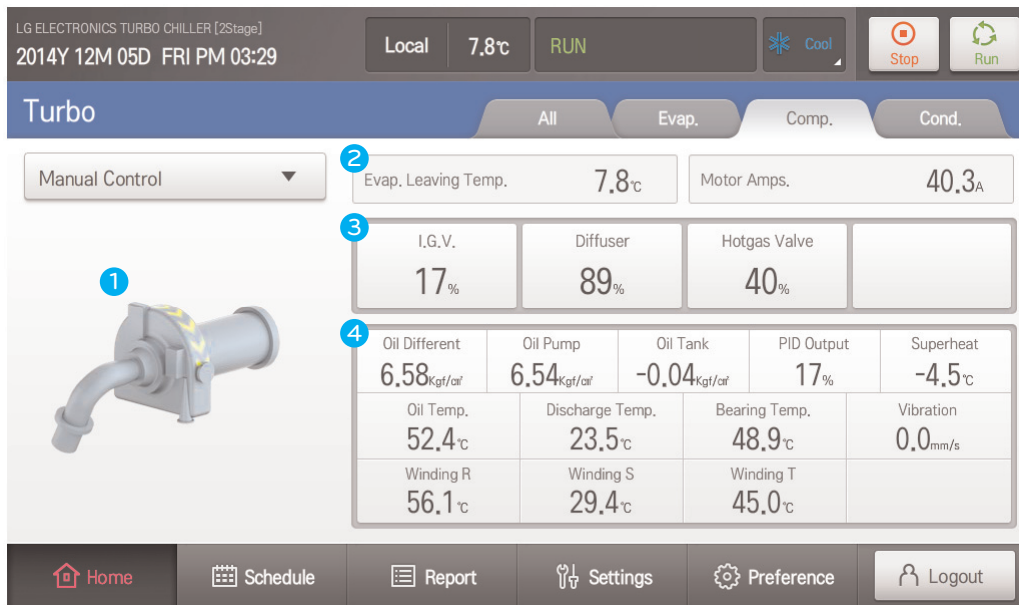

Figure 28. Compressor

No.	Component	Description
1	Animation	Provides the compressor animation.
2	Major information of the device	Displays evaporator leaving water temperature, inverter pressure and flow. Provides the same information when moving to other information tabs.
3	Main information	Provides inverter frequency/one stage variable diffuser/two stage variable diffuser/hot gas valve information.
4	Additional information	Provides compressor inverter outlet current/inverter outlet frequency/ inverter DC LINK voltage/inverter temperature/PID calculation/ motor winding R temperature/motor winding S temperature/motor winding T temperature/outlet temperature/bearing temperature/vibration information.

Table 11. Compressor Items

2.4. Condenser

Display DATA related to the condenser animation.

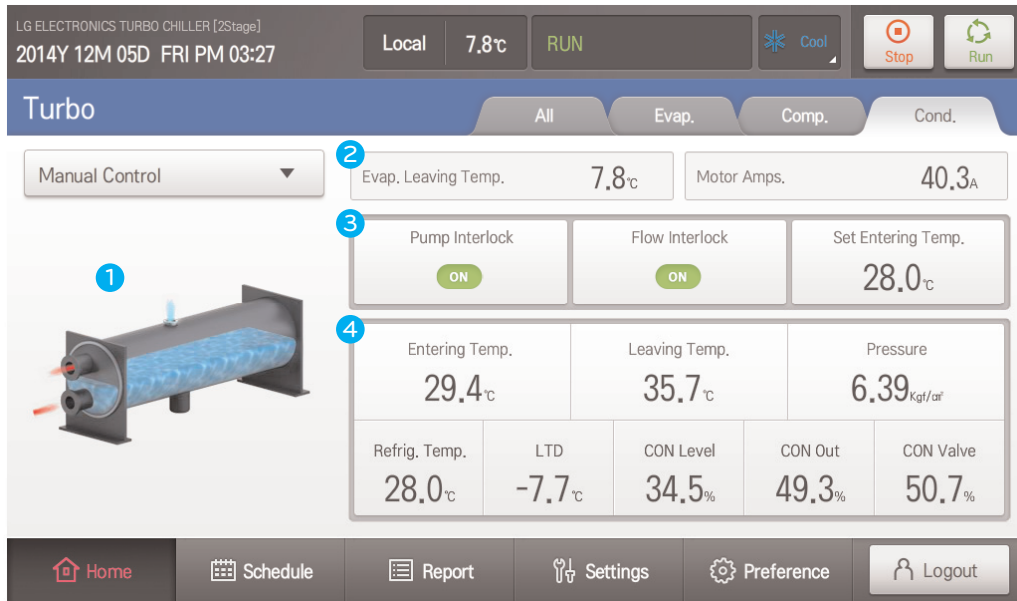

Figure 29. Condenser

No.	Component	Description
1	Animation	Provides the condenser animation.
2	Major information of the device	Displays evaporator leaving water temperature and motor current. Provides the same information when moving to other information tabs.
3	Main information	Provides condenser pump interlock/flow contact/pressure information.
4	Additional information	Provides condenser entering water temperature/leaving water temperature/pressure/refrigerant temperature/LTD/ CON level/CON calculation/CON valve information.

Table 12. Condenser items

2.5. Manual control

Display DATA related to the condenser animation screen.



Figure 30. Manual Control

No.	Component	Description
1	Vane opening	Displays a vane opening value and provides 0~100% control function when selecting manual/automatic setting and automatic by pressing the setting button. Manual opening does not work when the product doesn't operate since closing is enforced by circuit.
2	Diffuser opening	Displays a diffuser opening value and provides manual/automatic setting function and 0~100% control function when manual is selected by pressing the setting button.
3	Hot gas valve	Displays a hot valve value and provides manual/automatic setting function and 0~100% control function when manual is selected by pressing the setting button.
4	Eco valve	Displays a ECO valve value and provides manual/automatic setting function and 0~100% control function when manual is selected by pressing the setting button.
5	CON valve	Displays CON valve value and provides manual/automatic setting function and 0~100% control function when manual is selected by pressing the setting button.
6	Oil pump	Displays oil pump status and provides manual/automatic setting and ON/OFF control function by selecting the setting button. Manual stop does not work while operating to protect the Chiller.

Table 13. Manual Control Items

2.6. Home Screen Display Information

No.	Display menu	Display item	Display range	Display unit	Notes
1	View All	Displays evaporator leaving water temperature	3 digit and 1 decimal places (XXX.X)	°C(°F)	
2		Displays motor current	4 digit and 1 decimal places (XXXX.X)	A	
3		Displays evaporator flow contact	3 digit and 1 decimal places (XXX.X)	°C(°F)	
4		Displays evaporator entering water temperature	3 digit and 1 decimal places (XXX.X)	°C(°F)	
5		Displays evaporator leaving water temperature	3 digit and 1 decimal places (XXX.X)	°C(°F)	
6		Displays evaporator refrigerant temperature	3 digit and 1 decimal places (XXX.X)	°C(°F)	
7		Displays evaporator pressure	4 digit and 2 decimal places (XXXX.XX)	kgf/cm ² (kPa, psi, mmHg)	Note 2.
8		Displays compressor oil differential pressure	4 digit and 2 decimal places (XXXX.XX)	kgf/cm ² (kPa, psi)	
9		Displays compressor oil temperature	3 digit and 1 decimal places (XXX.X)	°C(°F)	
10		Displays compressor bearing temperature	3 digit and 1 decimal places (XXX.X)	°C(°F)	
11		Displays compressor motor winding temperature	3 digit and 1 decimal places (XXX.X)	°C(°F)	
12		Displays condenser flow contact	ON / OFF		
13		Displays condenser entering water temperature	3 digit and 1 decimal places (XXX.X)	°C(°F)	
14		Displays condenser leaving water temperature	3 digit and 1 decimal places (XXX.X)	°C(°F)	
15		Displays condenser refrigerant temperature	3 digit and 1 decimal places (XXX.X)	°C(°F)	
16		Displays condenser pressure	4 digit and 2 decimal places (XXXX.XX)	kgf/cm ² (kPa, psi)	
17	Evaporator	Displays evaporator pump interlock	ON / OFF		
18		Displays evaporator flow contact	ON / OFF		
19		Displays evaporator outlet water setting temperature	3 digit and 1 decimal places (XXX.X)	°C(°F)	
20		Displays remote temperature	3 digit and 1 decimal places (XXX.X)	°C(°F)	Note 1.
21		Displays evaporator entering water temperature	3 digit and 1 decimal places (XXX.X)	°C(°F)	
22		Displays evaporator leaving water temperature	3 digit and 1 decimal places (XXX.X)	°C(°F)	
23		Displays evaporator pressure	4 digit and 2 decimal places (XXXX.XX)	kgf/cm ² (kPa, psi)	
24		Displays evaporator refrigerant temperature	3 digit and 1 decimal places (XXX.X)	°C(°F)	
25		Displays LTD	3 digit and 1 decimal places (XXX.X)	°C(°F)	
26		Displays evaporator flow	4 digit places (XXXX)	m ³ /h (gal/min)	Note 1.
27		Displays ECO level	0.0% ~ 100.0% (XXX.X)	%	Note 1.
28		Displays ECO calculation	0.0% ~ 100.0% (XXX.X)	%	Note 1.
29		Displays ECO valve	0.0% ~ 100.0% (XXX.X)	%	Note 1.
30	Compressor	Displays vane opening	0% ~ 100% (XXX)	%	
31		Displays diffuser opening	0% ~ 100% (XXX)	%	
32		Displays hot gas valve	0% ~ 100% (XXX)	%	
33		Displays inverter	3 digit and 1 decimal places (XXX.X)	Hz	
34		Displays oil differential pressure	4 digit and 2 decimal places (XXXX.XX)	kgf/cm ² (kPa, psi)	
35		Displays oil pump pressure	4 digit and 2 decimal places (XXXX.XX)	kgf/cm ² (kPa, psi)	
36		Displays oil tank pressure	4 digit and 2 decimal places (XXXX.XX)	kgf/cm ² (kPa, psi)	Note 1.
37		Displays P.I.D calculation	0 ~ 100 (XXX)		
38		Displays overheat	3 digit and 1 decimal places (XXX.X)	°C(°F)	
39		Displays compressor oil temperature	3 digit and 1 decimal places (XXX.X)	°C(°F)	
40		Displays compressor outlet temperature	3 digit and 1 decimal places (XXX.X)	°C(°F)	

No.	Display menu	Display item	Display range	Display unit	Notes
41	Compressor	Displays bearing temperature	3 digit and 1 decimal places (XXX.X)	°C(°F)	
42		Displays vibration	3 digit and 1 decimal places (XXX.X)	mm/s	Note 1
43		Displays power	4 digit places (XXXX)	KW	Note 1.
44		Displays motor winding R temperature	3 digit and 1 decimal places (XXX.X)	°C(°F)	Note 1
45		Displays motor winding S temperature	3 digit and 1 decimal places (XXX.X)	°C(°F)	Note 1.
46		Displays motor winding T temperature ^{A)}	3 digit and 1 decimal places (XXX.X)	°C(°F)	Note 1.
47		Displays motor bearing temperature	3 digit and 1 decimal places (XXX.X)	°C(°F)	Note 1.
48	Condenser	Displays condenser pump interlock	ON / OFF		
49		Displays condenser flow contact	ON / OFF		
50		Displays condenser inlet water setting temperature	3 digit and 1 decimal places (XXX.X)	°C(°F)	
51		Displays condenser entering water temperature	3 digit and 1 decimal places (XXX.X)	°C(°F)	
52		Displays condenser leaving water temperature	3 digit and 1 decimal places (XXX.X)	°C(°F)	
53		Displays condenser pressure	4 digit and 2 decimal places (XXXX.XX)	kgf/cm ² (kPa, psi)	
54		Displays condenser refrigerant temperature	3 digit and 1 decimal places (XXX.X)	°C(°F)	
55		Displays LTD	3 digit and 1 decimal places (XXX.X)	°C(°F)	
56		Displays condenser flow	4 digit places (XXXX)	m ³ /h (gal/min)	Note 1.
57		Displays CON level	0.0% ~ 100.0% (XXX.X)	%	Note 1.
58		Displays CON calculation	0.0% ~ 100.0% (XXX.X)	%	Note 1.
59	Displays CON Valve	0.0% ~ 100.0% (XXX.X)	%	Note 1.	
60	Manual control	Vane opening	Automatic/manual, 3 digit places (XXX)	%	
61		Diffuser opening	Automatic/manual, 3 digit places (XXX)	%	Note 1.
62		Hot gas valve	Automatic/manual, 3 digit places (XXX)	%	Note 1.
63		ECO valve	Automatic/manual, 3 digit places (XXX)	%	Note 1.
64		CON valve	Automatic/manual, 3 digit places (XXX)	%	Note 1.
65		Oil pump	Automatic/manual, ON/OFF	-	

Note 1. Displayed on the screen depending on whether the sensor is used or not.

Note 2. Displayed in mmHg unit for R123 model.

Table 14. Home Screen Display and Setting Items

5-3. Schedule

The schedule is function for the device to implement desired actions at a specific time by appointing actions in advance.

The device can operate automatically only with the set schedules if the device is controlled at a fixed schedule. However, the schedule control for starting the operation can be implemented only when the device is standby to implement scheduled actions.

3.1 View Schedule

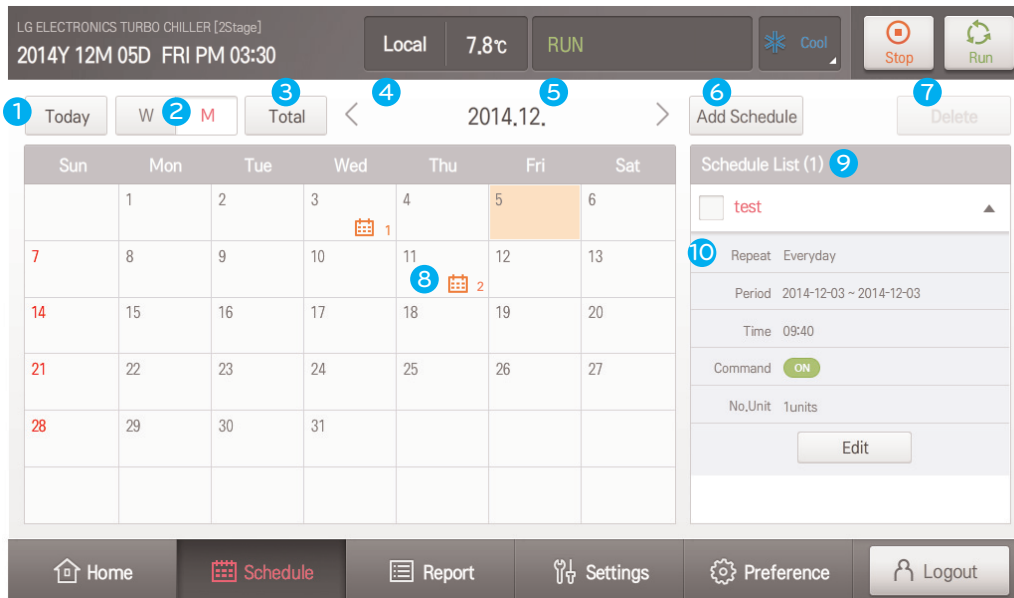

Figure 31. Schedule

No.	Component	Description
1	Today button	Goes to current year/month of the calendar and display screen for today's date when selecting the button.
2	Weekly/monthly display button	Provides weekly/monthly screen when selecting the button.
3	All schedule button	Displays all schedule information lists that are currently stored on the device on the right side of schedule.
4	Monthly navigation button	Navigation to move to the last/next month. The left button and right button provide functions to go to the last month and next month respectively.
5	Calendar year/month	Displays year/month that the calendar is displaying
6	Add schedule	You may add new schedules and go to add schedule screen when selecting the button.
7	Delete schedule	You may delete registered schedules. The button is enabled only when the checkbox is checked.
8	Display schedule	Displays whether there is a schedule or not by icons. Icon and number is displayed if there is any schedule.
9	Schedule	Provide schedule lists for selected date.
10	Checkbox	"Delete schedule" button is enabled when checkbox is selected.
11	Edit schedule	Provides schedule edit function when selecting the button.

Table 15. Schedule Items

3.2 Add/Edit Schedule

Figure 32. Add/Edit Schedule

No.	Component	Description
1	Enter schedule name	Enters schedule name after selecting
2	Enter setting time	Enters time to implement corresponding actions.
3	Set setting period	Sets valid period for corresponding schedules. *Default when adding schedules: today's date .
4	Repeating pattern setting combo box	Set repeating pattern for schedules. Available to select once/everyday/selected day setting .
5	Day setting button	Available to set when repeating pattern is day selection. Repeat schedule on selected day for setting period.
6	Operation status button	Setting button that defines the operation status when implementing schedules.
7	Operation mode	Setting button that defines operation mode when implementing schedules. Cooling operation in case of air conditioning chillers. Cooling and ice manufacturing operation in case of ice thermal chiller. Cooling and heating operation in case heat pump chiller is set.
8	Motor current block	Setting button that defines motor current block when implementing schedules. Available to adjust in the range of 50-100% by pressing up/down button.
9	Cooling setting temperature	Setting button that defines cooling setting temperature when implementing schedules. Available to adjust in the range of 3-50 °C by pressing the up/down button.
10	Heating setting temperature (heat pump chiller) Ice manufacturing setting temperature (ice storage chiller)	Setting button that defines heating/ice manufacturing setting temperature when implementing schedules. Available to adjust in the range of 10-90 °C / -20 ~ 30 °C by pressing the up/down button.
11	Cancel	Returns to the previous screen after cancelling all input until now
12	Confirm	Confirms, stores and applies all input until now Return to the previous screen when completed
13	Animation	Provides animation of the current chiller *Provides corresponding image depending on the model no. (2stage/R134a/R123)

Table 16. Add/Edit Schedule Items

5-4. History

This function displays the history related to operation and errors of the Chiller.

4.1. View History (operation/ Error)

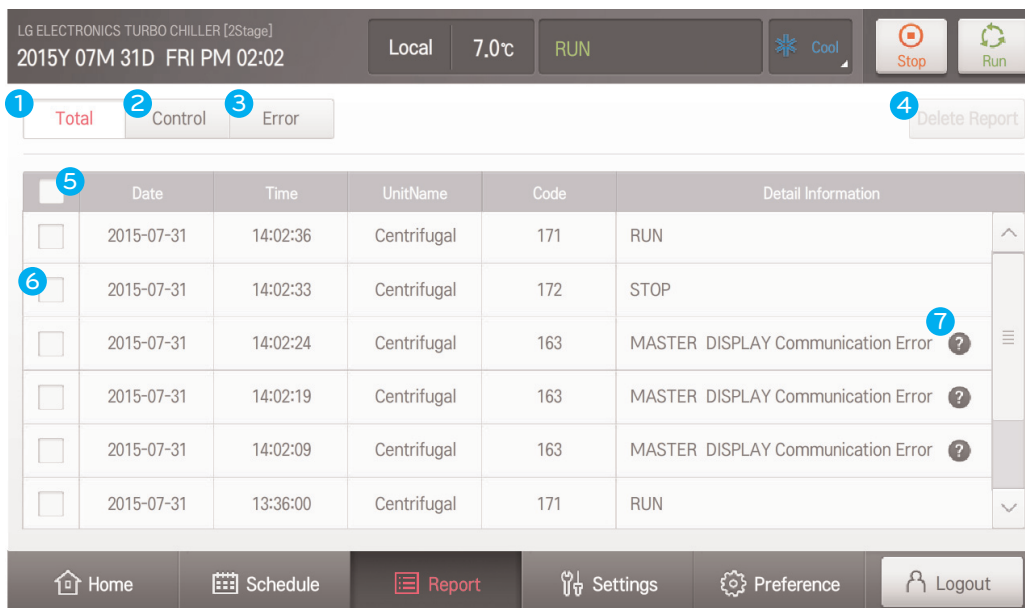

Figure 33. History

No.	Component	Description
1	All category tab	Provides all information whether it is an operation or error when selecting the all category tab.
2	Operation category tab	Provides list information corresponding to operation data when selecting the operation button.
3	Error category tab	Provides list information corresponding to error data when selecting the error button.
4	Report delete button	Function to delete operation/error data report. Delete function is enabled when each operation/error data checkbox is selected.
5	Operation/error history data	Provides operation/error occurrence date/occurrence time/ device name/code/detailed information.
6	Checkbox	Button available to select for each operation/error data.
7	View details button	Provides details for each list. Provides detailed information pop-up of a selected list when selected.

Table 17. History Items

4.2 View details

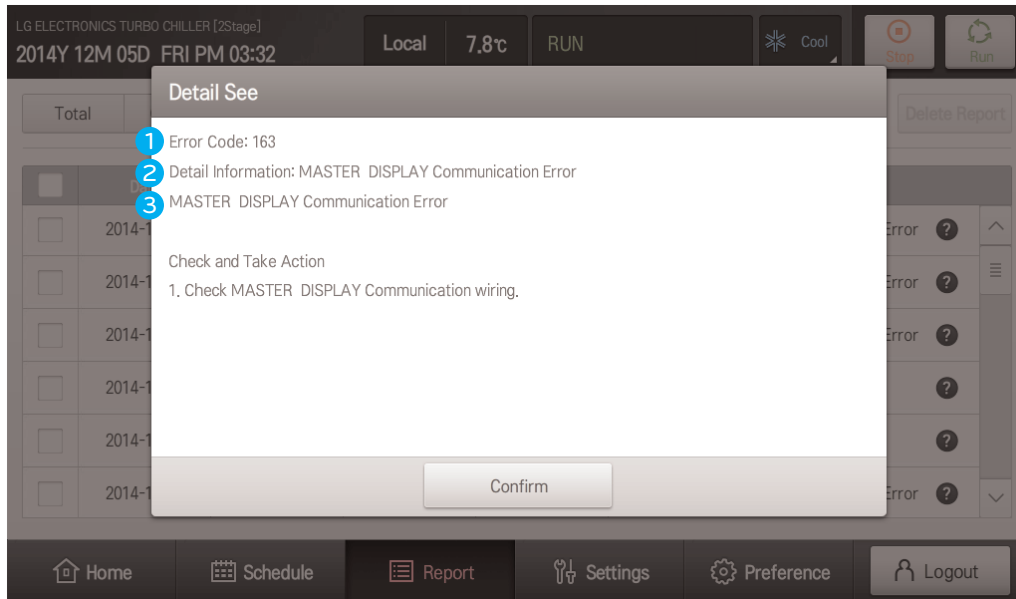

Figure 34. View Details

No.	Component	Description
1	Error code	Displays error code
2	Detailed information	Displays error message information.
3	Help	Provides cause of error and help inspection and corrective actions.

Table 18. View Details Items

5-5. Device Setting

5.1 User

5.1.1 Basic Setting

This menu for users to set values needed for operation of the Chiller.

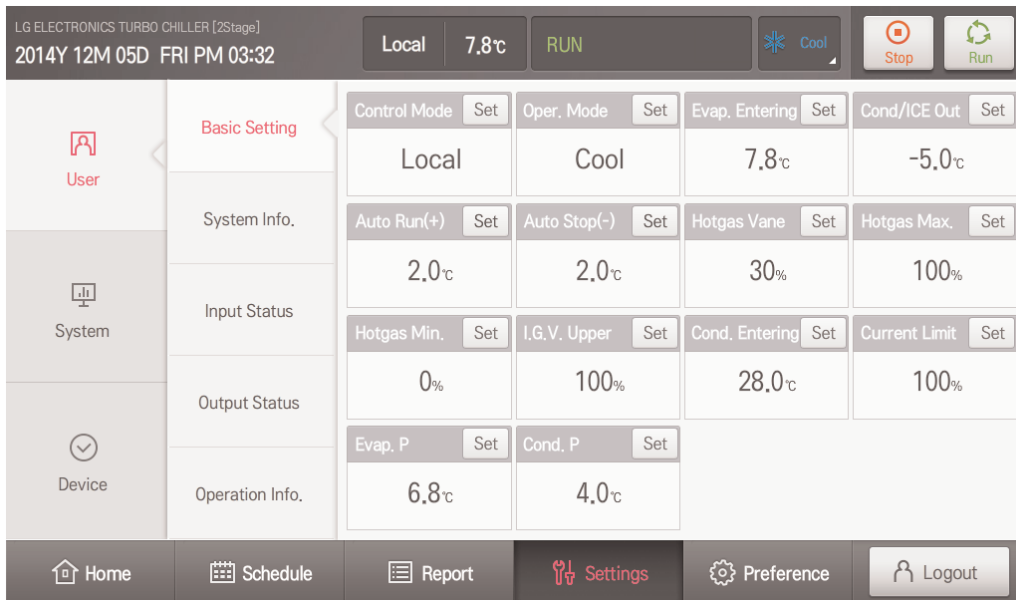

Figure 35. Basic Setting

1) Select Control Mode

- Local: This is to start/stop the Chiller by using the start/stop key on the control board of the controller at the site of installation.
- Remote: This is to start/stop the Chiller by using remote start/stop (zero voltage contact signal: switch, relay contact signal) from a remote area (office on site or automatic control board).
- Schedule: This is to start/stop the Chiller automatically according to scheduled programs by setting time and temperature in the controller to start/stop the Chiller.

2) Select Operation Mode

- Standard Chiller: Provides cooling setting.
- Ice Thermal Chiller: Provides cooling/ice manufacturing setting.
- Heat pump Chiller: Provides cooling/heating setting.

3) P.I.D Temperature Control

The optimized control is implemented by minimizing Under-Shoot and Over-Shoot when automatically/manually changing time to approach a goal, steady status error, initial operation and vane operation compared to the previous method by applying unique P (proportion), I (integration) and D (differentiation) algorithms to cold water temperature control.

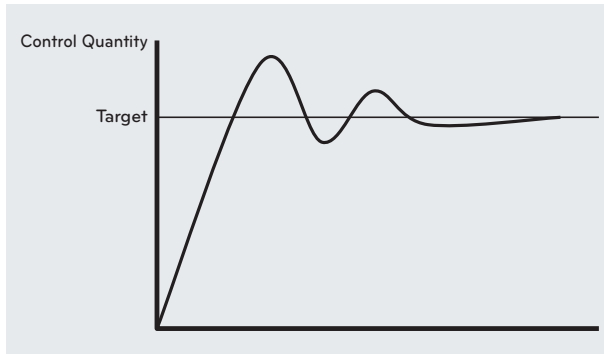

Figure 36. Previous Control Method

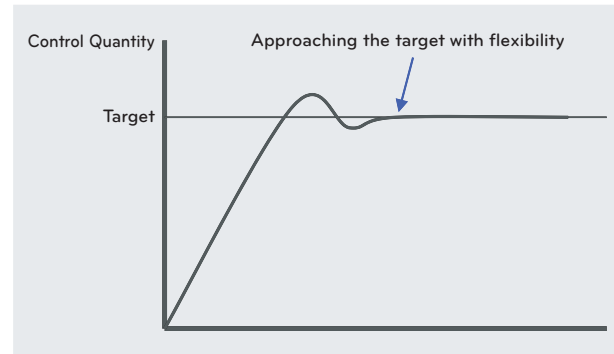

Figure 37. LG Control Method

(1) Evaporator exit water temperature

This is menu to set to the P.I.D. control temperature of the cold water outlet when cooling
This is setting temperature is a goal in P.I.D control calculation.

(2) Evaporator Temperature P

Set P value of proportional control sections used for P.I.D control of cold water temperature when cooling.

(3) Leaving Water Temperature of condenser/ice manufacturing

This menu sets control temperature of exit in ice manufacturing mode.

4) Fan inverter control of the cooling tower

This is a control method to supply stable coolant inlet temperature, and this is applied when an inverter is used in a fan motor control of the cooling tower.

Inverter should be selected for main menu/system menu/safety control setting/cooling tower control of the control device.

- Operation is available only when an inverter is attached on the user MCC(Motor Control Center) panel.

This is an option, and this can be applied after a consultation with LG.

- Control output of the cooling tower fan is available to have one of 4~20mA, 0~5Vdc or 0~10Vdc signals from the controller.

(1) Condenser temperature P

Set P, proportional section, of the P.I.D control when using an inverter to control coolant inlet control.

(2) Condenser entering water temperature

Set coolant inlet temperature that is the standard for the inverter control of the cooling tower.

5) Motor Current Block

This is to set motor and current control actions to protect the motor from overload.

The current block action is implemented as shown below, and temperature control is not implemented when current block action is under operation.

However, it is implemented in accordance with the P.I.D calculation value when P.I.D calculation value is smaller than the vane opening value while current control action is under operation.

- Current Block Action

For example, if the current block is set to 80% and rated current is 518A, at point (1) when the current is 80% of the rated current as shown in the figure below, vane opening stops, and when the current reaches point (2) that is 105% of the current block setting, the vane is closed until current goes down to point (1).

When the current is lower than the point (1), a normal temperature control starts again.

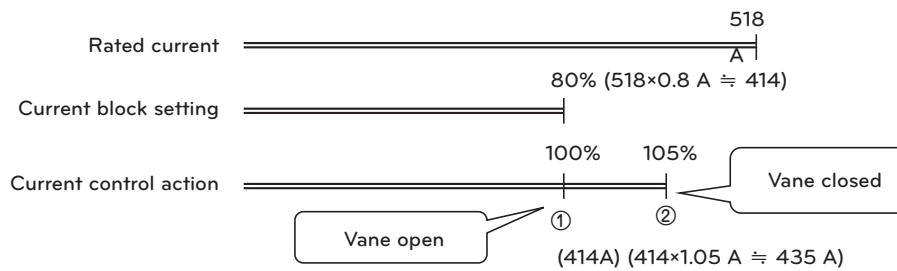

Figure 38. Motor Current Block

6) Guide Vane Maximum

This function is to protect the motor from overload or to block a load of the Chiller artificially.

This blocks the guide vane from opening bigger than the setting.

7) Hot Gas (Vane %)

This is an item to set when applying a hot gas bypass valve.

Action to open a hot gas bypass valve is implemented when opening reaches the setting when closing the vane after reading feedback signals for controlling the opening of the guide vane.

If this value is set to 30%, the hot gas bypass valve opens from the point when opening of the main guide vane reaches 30%, and when opening of the guide vane becomes 0%, the hot gas bypass valve opens to 100% (hot gas maximum setting).

8) Hot Gas Maximum

This is an item to set when applying the hot gas bypass valve.

This item is to set the maximum value of opening of the hot gas bypass valve and blocks the valve from opening larger than the setting.

If this value is set to 50%, the hot gas bypass valve does not open larger than that value.

9) Hot Gas Minimum

This is an item to set when applying the hot gas bypass valve.

The item is to set the minimum value of opening of the hot gas bypass valve and blocks the valve from closing smaller than the setting.

If this value is set to 5%, the hot gas bypass valve does not close smaller than that value.

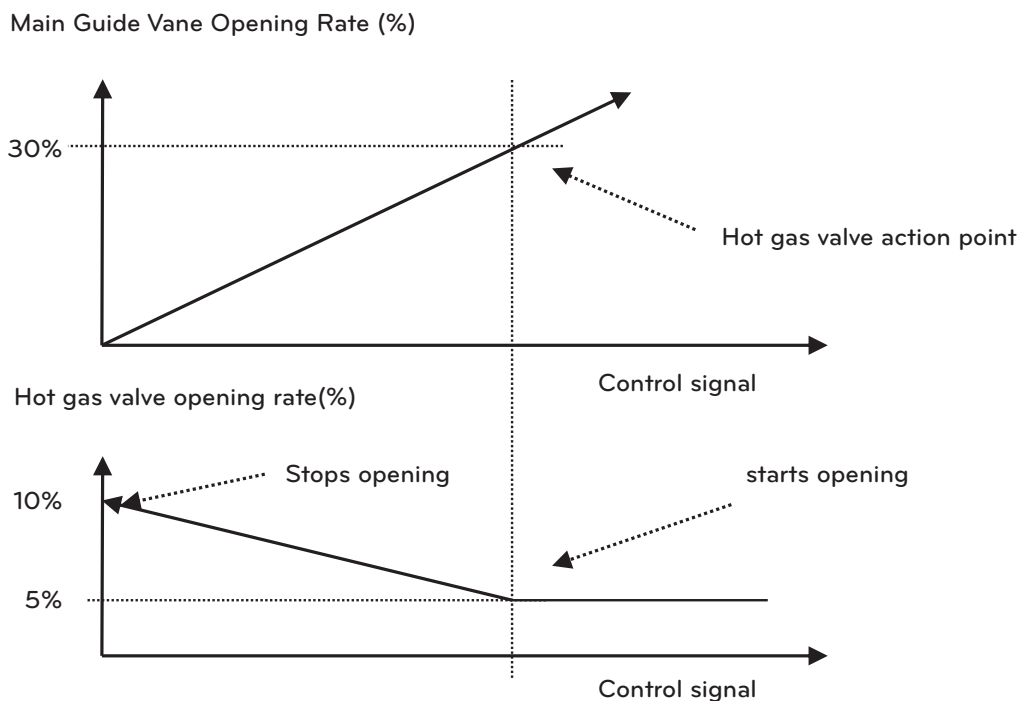

Figure 39. Hot Gas Valve Action

Item name	Setting Availability	Setting UI	Unit	Minimum Value	Maximum value	Adjustment Unit	Notes
Control mode	●	Select a list	-	-	-	-	Local/Schedule/Remote
Operation mode	●	Select a list	-	-	-	-	Control Mode : Cool → Cool
							Control Mode : Cold → Cool/Cold
							Control Mode : Heat → Cool/Heat
Evaporator leaving water temperature	●	Select a number	°C	3	50	0.1	
Condenser leaving water temperature	●	Select a number	°C	10	90	0.1	Operation Mode : Heat
				-20	30	-5	Operation Mode : Cold
Automatic operation (+)	●	Select a number	°C	0	10	0.1	
Automatic temperature (-)	●	Select a number	°C	0	10	0.1	
Hot gas (vane %)	●	Select a number	%	0	100	1	
Hot gas maximum	●	Select a number	%	1	100	1	
Hot gas minimum	●	Select a number	%	0	100	1	
Guide vane Maximum	●	Select a number	°C	1	100	1	
Condenser entering water temperature	●	Select a number	°C	10	50	0.1	
Motor current block	●	Select a number	%	50	100	1	
Evaporator temperature P	●	Select a number	°C	1	10	0.1	
Condenser temperature P	●	Select a number	°C	1	10	0.1	

Table 19. Basic Setting Items

5.1.2 System Check

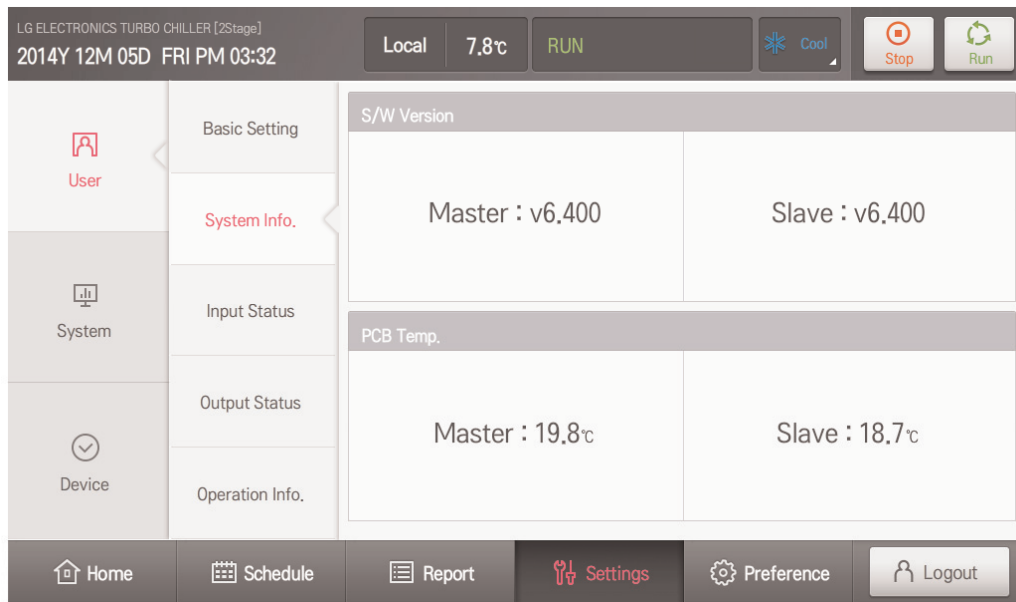

Figure 40. System Check

Item name	Setting availability	Setting UI	Unit	Minimum value	Maximum value	Adjustment Unit	Notes
Master	-	-	V	-	-	-	Monitoring (SW version)
Slave	-	-	V	-	-	-	Monitoring (SW version)
Master	-	-	°C	-	-	-	Monitoring (PCB temperature)
Slave	-	-	°C	-	-	-	Monitoring (PCB temperature)

Table 20. System Check Items

5.1.3 Check Input status

Display ON (Closed circuit)/OFF (open circuit) of the digital input port.

This menu is to check input signal ground stages connected to the control board of the Chiller.

When inspecting the digital input, make sure to check the control circuit drawing so that other signals are not input to the input terminal of the controller.

Mixed connection with other signal lines may damage the controller board.

5.1.3.1 Master

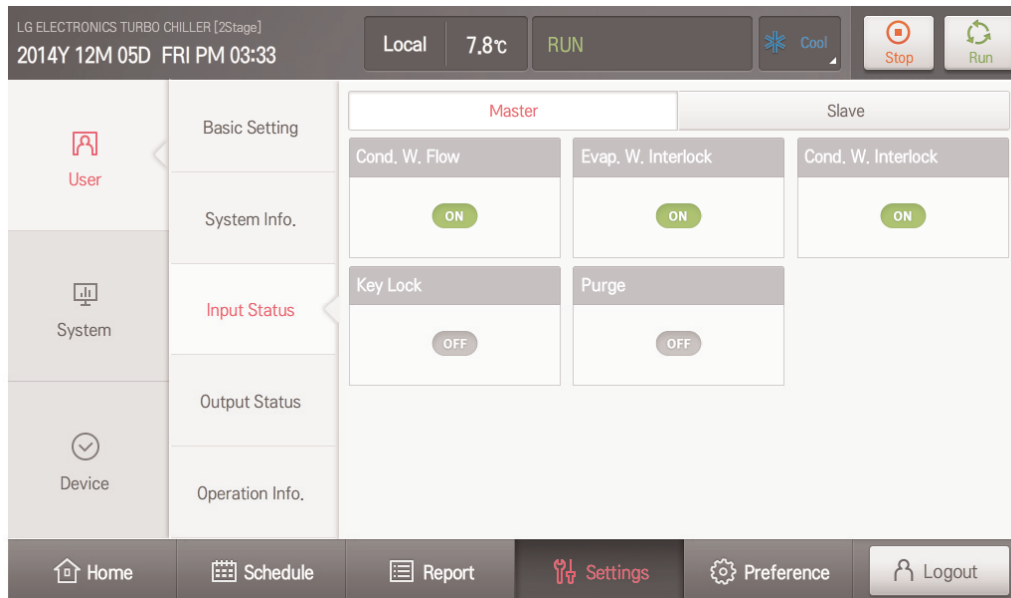

Figure 41. Input Status Check Master

Item Name	Setting availability	Contact Action Status	Notes
Normal Condenser flow contact	-	When flow is normal: closed circuit	ON/OFF
Evaporator pump interlock	-	When pump operates: closed circuit	ON/OFF
Condenser pump interlock	-	When pump operates: closed circuit	ON/OFF
Key Lock	-	-	ON/OFF
Purge	-	-	ON/OFF

Table 21. Input status Check Master Items

5.1.3.2 Slave

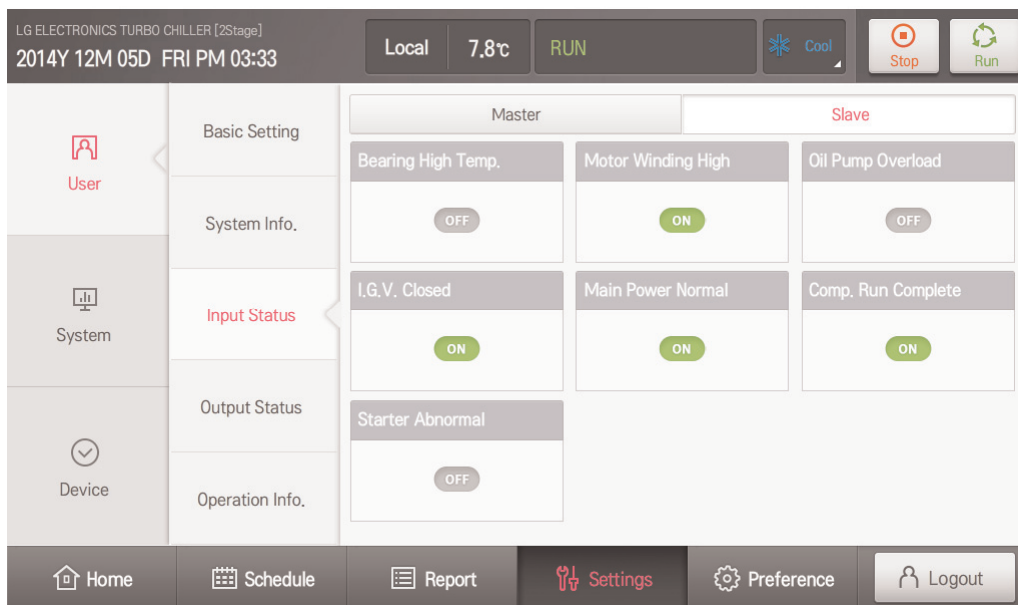

Figure 42. Input Status Check Slave

Item Name	Setting availability	Contact Action Status	Notes
High bearing temperature contact	-	When temperature is high: closed circuit	ON/OFF
High motor winding temperature contact	-	When temperature is high: closed circuit	ON/OFF
Oil pump overload contact	-	When there is overload: closed circuit	ON/OFF
Closed vane contact	-	When vane closes: closed circuit	ON/OFF
Normal compressor motor power	-	When power is supplied: closed circuit	ON/OFF
Compressor operation check	-	When compressor operate: closed circuit	ON/OFF
Abnormal starter	-	When there is abnormality: closed circuit	ON/OFF

Table 22. Input status Check Slave Items

5.1.4 Check Output Status

Display the status of ON (Closed circuit)/OFF (open circuit) of the digital output port and analog output.

This menu is to display the output status by internal calculation in the controller, and is structured in the way that output results by controller calculations can be found.

Status and wirings of the controller I/O board should be inspected when the actual output status and menu differ.

5.1.4.1 Master

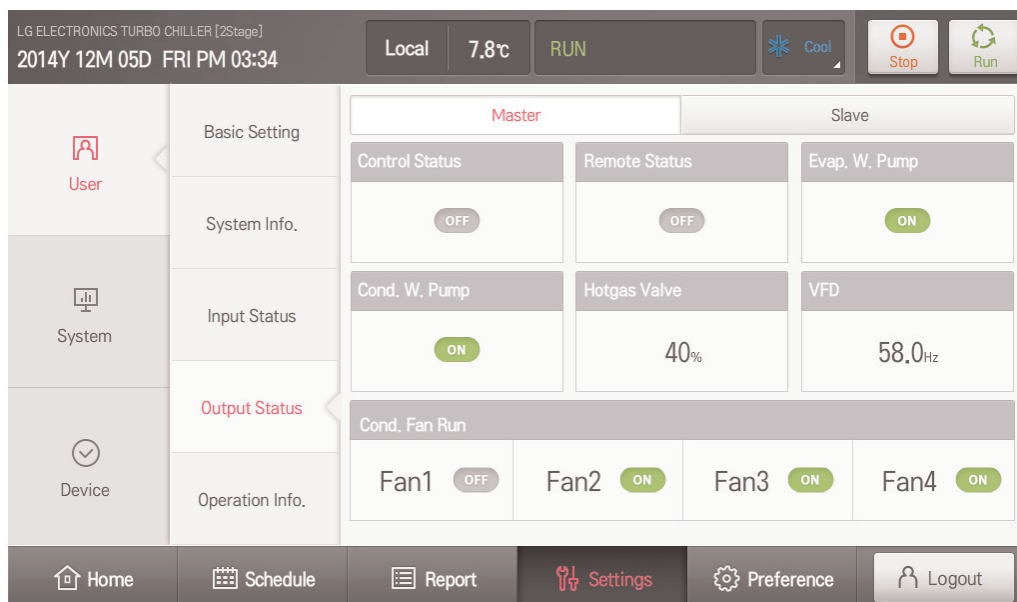

Figure 43. Output Status Check Master

Item Name	Setting availability	Contact Action Status	Notes
Control mode display	-	When it is on ice manufacturing mode: closed circuit	ON/OFF
Remote selection display	-	When selecting remote operation: closed circuit	ON/OFF
Evaporator water pump operation	-	When pump operates: closed circuit	ON/OFF
Condenser water pump operation	-	When pump operates: closed circuit	ON/OFF
Hot gas valve	-	-	ON/OFF
VFD	-	-	ON/OFF
Cooling tower fan 1 operation	-	When pump operates: closed circuit	ON/OFF
Cooling tower fan 2 operation	-	When pump operates: closed circuit	ON/OFF
Cooling tower fan 3 operation	-	When pump operates: closed circuit	ON/OFF
Cooling tower fan 4 operation	-	When pump operates: closed circuit	ON/OFF

Table 23. Output Status Check Master Items

5.1.4.2 Slave

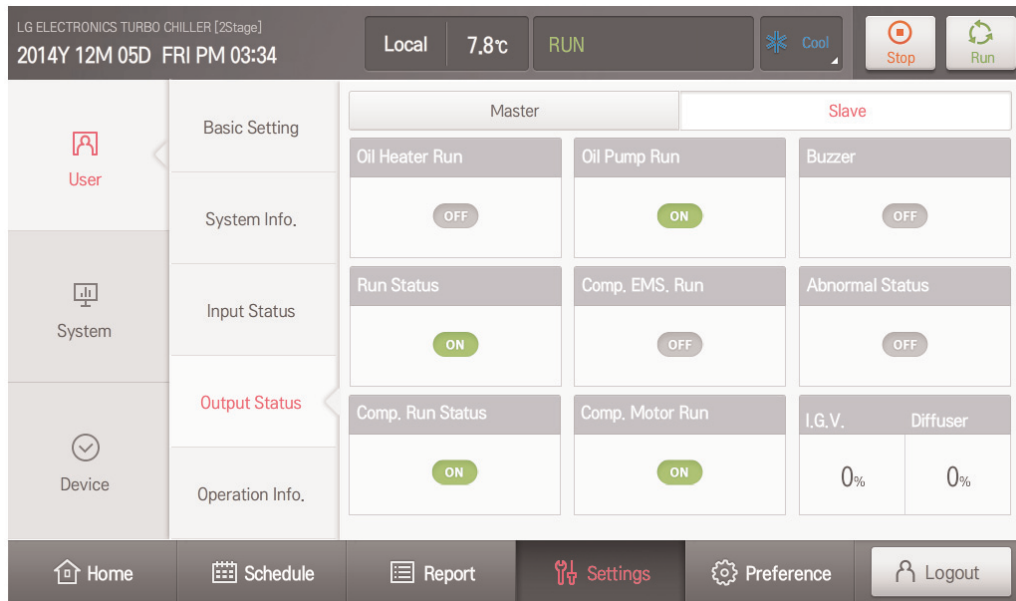

Figure 44. Output Status Check Slave

Item Name	Setting availability	Contact Action Status	Notes
Oil heater run	-	When heater operates: Closed circuit	ON/OFF
Oil pump run	-	When pump operates: Closed circuit	ON/OFF
Buzzer	-	When there is abnormality: Closed circuit	ON/OFF
Run status display	-	When operating: Closed circuit	ON/OFF
Compressor abnormal stop	-	When warning alarms: Closed circuit	ON/OFF
Abnormality status display	-	When there is abnormality: Closed circuit	ON/OFF
Compressor run status	-	When compressor operates Closed circuit	ON/OFF
Compressor motor run	-	When motor operates: Closed circuit	ON/OFF
Vane opening	-	-	%
Diffuser opening	-	-	%

Table 24. Output Status Check Slave Items

5.1.5 Check Operation Hours

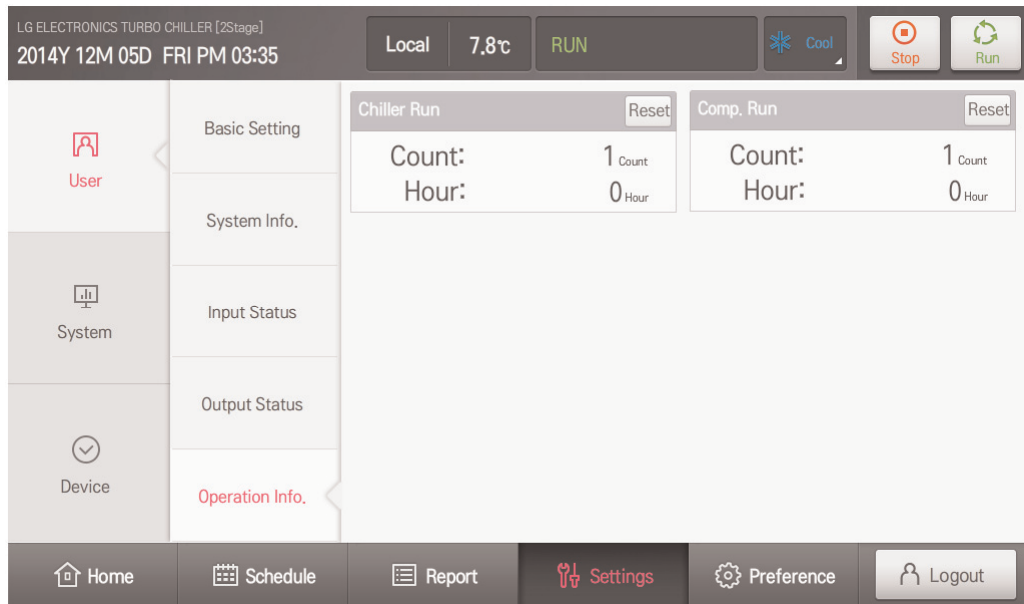

Figure 45. Check Operation Hours

Item name	Setting availability	Setting UI	Unit	Minimum value	Maximum value	Adjustment Unit	Notes
Number of Chiller operation	●	-	Rounds	-	-	-	-
Hours of Chiller operation	●	-	Hours	-	-	-	-
Number of compressor operation	●	-	Rounds	-	-	-	-
Hours of compressor operation	●	-	Hours	-	-	-	-

Table 25. Operation Hours Check Items

No.	Component	Description
1	Initialization button	When logged in with the installer account, chiller operation hours/numbers are initialized to 0 by pressing the button
2	Initialization button	When logged in with the installer account, compressor operation hours/numbers are initialized to 0 by pressing the button

Table 26. Operation Hours Check Initialization

5.2 System

5.2.1 Control Information

This is menu for the user to set values needed to operate the Chiller.

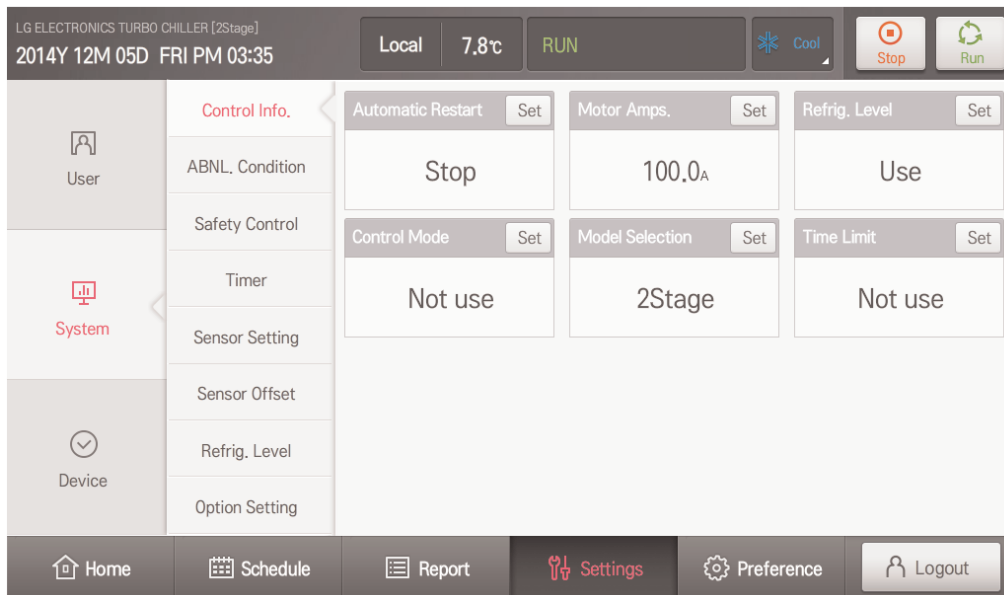

Figure 46. Control Information

Item name	Setting availability	Setting UI	Unit	Minimum value	Maximum value	Adjustment Unit	Notes
Automatic restart	●	Select a list	-	-	-	-	Stop/Restart
Motor Amps	●	Select a number	A	0	3000	0.1	
Refrigerant level use setting	●	Select a list	-	-	-	-	Use/not use
Control mode	●	Select a list	-	-	-	-	Unused/Cold/Heat
Model selection	●	Select a list	-	-	-	-	2stage/R134a/R123
Time block	●	Select a list	-	-	-	-	Use/not use

Table 27. Control Information Items

5.2.2 Abnormality Condition

This is menu to set values related to the abnormality of the Chiller.

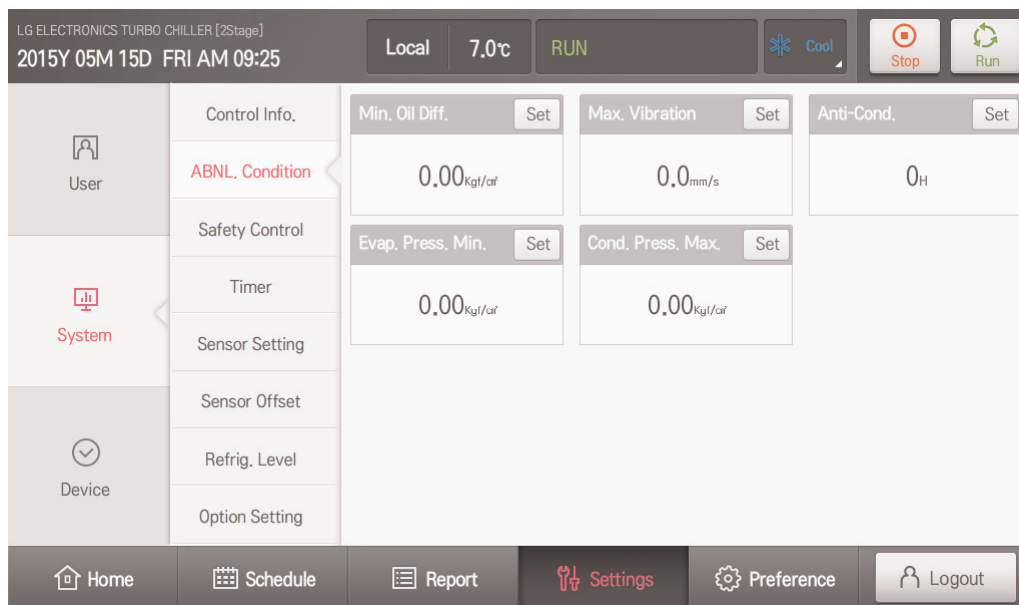

Figure 47. Abnormality Condition

1) Oil differential pressure Maximum

This is to set the minimum oil differential pressure.

The chiller stops due to abnormality if an oil differential pressure is below the setting when operating.

2) Low evaporator pressure

This is to set the minimum evaporator pressure.

The chiller stops due to abnormality if an evaporator pressure is lower than the setting when operating.

3) High condenser pressure

This is to set condenser pressure maximum.

The Chiller stops due to abnormality if a condenser pressure is lower than the setting when operating.

Item Name	Setting availability	Setting UI	Unit	Minimum Value	Maximum Value	Adjustment Unit	Notes
Minimum Oil differential pressure	●	Select a number	kgf/cm ²	0	3	0.01	
Maximum vibration	●	Select a number	mm/s	0	100	0.1	
Condense block time	●	Select a number	hr	0	48	1	
Low evaporator pressure	●	Select a number	kgf/cm ²	0	13	0.01	
High condenser pressure	●	Select a number	kgf/cm ²	0	35	0.01	

Table 28. Abnormality Condition Items

5.2.3 Safety Control

This is to set values related to the safety control of the Chiller.

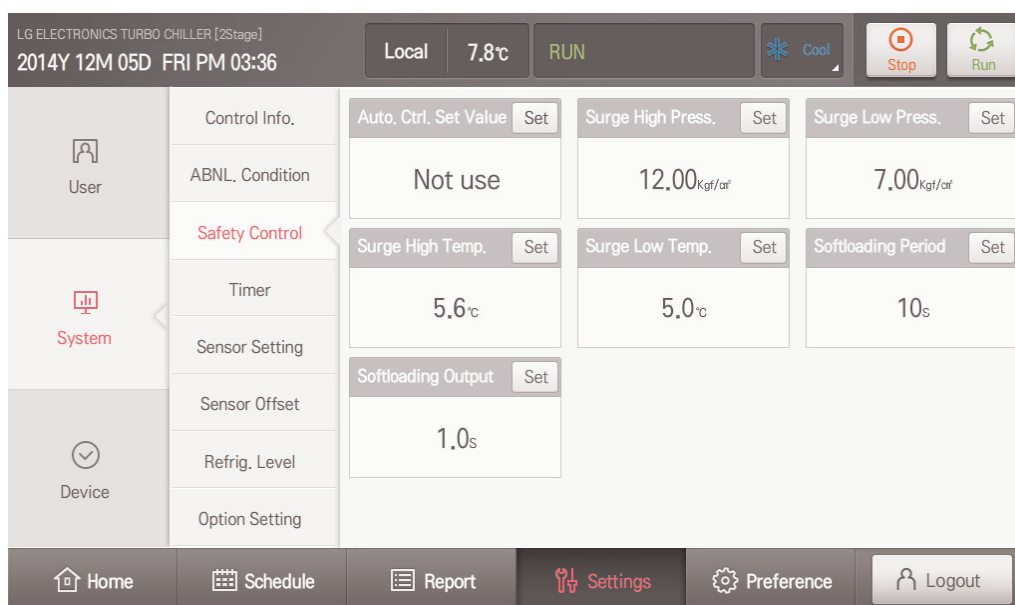

Figure 48. Safety Control

Item name	Setting availability	Setting UI	Unit	Minimum value	Maximum value	Adjustment Unit	Notes
Automatic Control Setting Value	●	Select a list	-	-	-	-	Use/Not use
Surge High Pressure	●	Select a number	kgf/cm ²	0	18	0.01	
Surge Low Pressure	●	Select a number	kgf/cm ²	0	18	0.01	
Surge High Temperature	●	Select a number	°C	0	12	0.01	
Surge Low Temperature	●	Select a number	°C	0	12	0.01	
Soft Loading Period	●	Select a number	Seconds	1	60	1	
Soft loading Output	●	Select a number	seconds	0.5	60	1	

Table 29. Safety Control Items

5.2.4 Timer

This is to set values related the timer needed for operation of the Chiller.

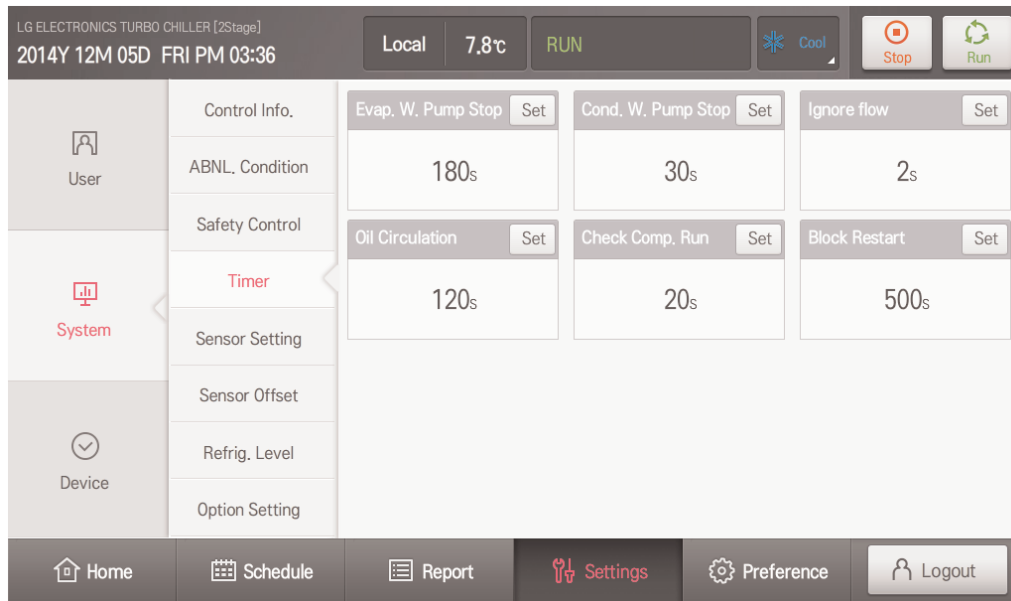

Figure 49. Timer

Item name	Setting availability	Setting UI	Unit	Minimum value	Maximum value	Adjustment Unit	Notes
Evaporator Water Pump Stop	●	Select a number	Seconds	1	1800	1	
Condenser Water Pump Stop	●	Select a number	Seconds	1	1800	1	
Ignore Flow	●	Select a number	Seconds	1	60	1	
Oil Circulation	●	Select a number	Seconds	30	600	1	
Check Compressor Run	●	Select a number	Seconds	5	60	1	
Block Restart	●	Select a number	Seconds	5	3600	1	

Table 30. Timer Items

5.2.5 Sensor Setting

In the master tab, the current sensor and signal can be set. Make sure to set accurately, and it is only valid when the sensor is being used.

In the guide vane/diffuser vane/ECO valve/CON valve tab, manually change AD values of the guide vane/diffuser vane/ ECO valve/ CON valve to minimum/maximum, change the sensor setting mode to ON and then select corresponding setting (minimum setting, maximum setting) to end the setting.

5.2.5.1 Master

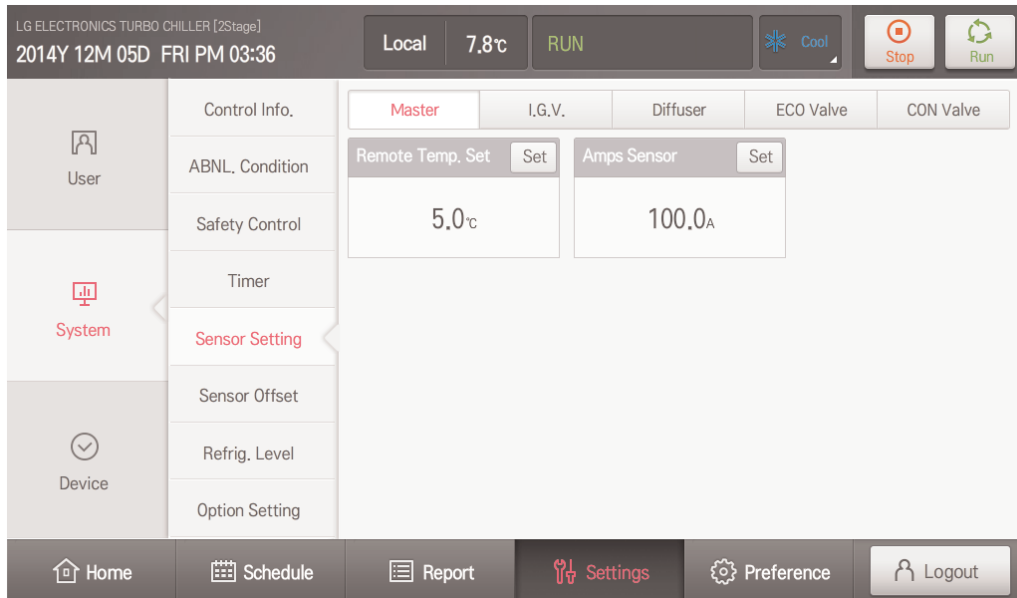

Figure 50. Sensor Setting Master

Item name	Setting availability	Setting UI	Unit	Minimum value	Maximum value	Adjustment Unit	Notes
Remote Temperature Setting	●	Select a number	°C	0	10	0.1	
Amps Sensor	●	Select a number	A	0	3000	0.1	

Table 31. Sensor Setting Master Items

5.2.5.2 Guide Vane

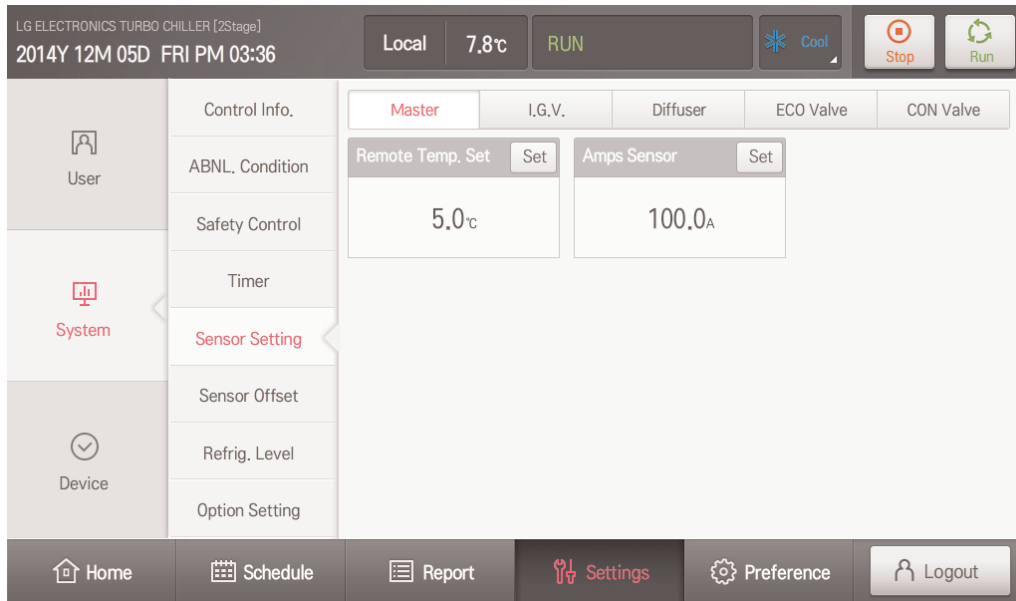

Figure 51. Sensor Setting Guide Vane

Item name	Setting availability	Setting UI	Unit	Minimum value	Maximum value	Adjustment Unit	Notes
Sensor setting mode	●	Select a list	-	-	-	-	ON/OFF
Manual/Automatic setting	●	Button	%	0	100	1	Manual/automatic
Minimum Guide Vane	●	Button	-	0	1023	-	(Available when the sensor setting mode is ON) Available to press the minimum button
Maximum Guide Vane	●	button	-	0	1023	-	(Available when the sensor setting mode is ON) Available to press the maximum button
Guide Vane AD	-	-	-	0	1023	-	Monitoring

Table 32. Sensor Setting Guide Vane Items

5.2.5.3 Diffuser Vane

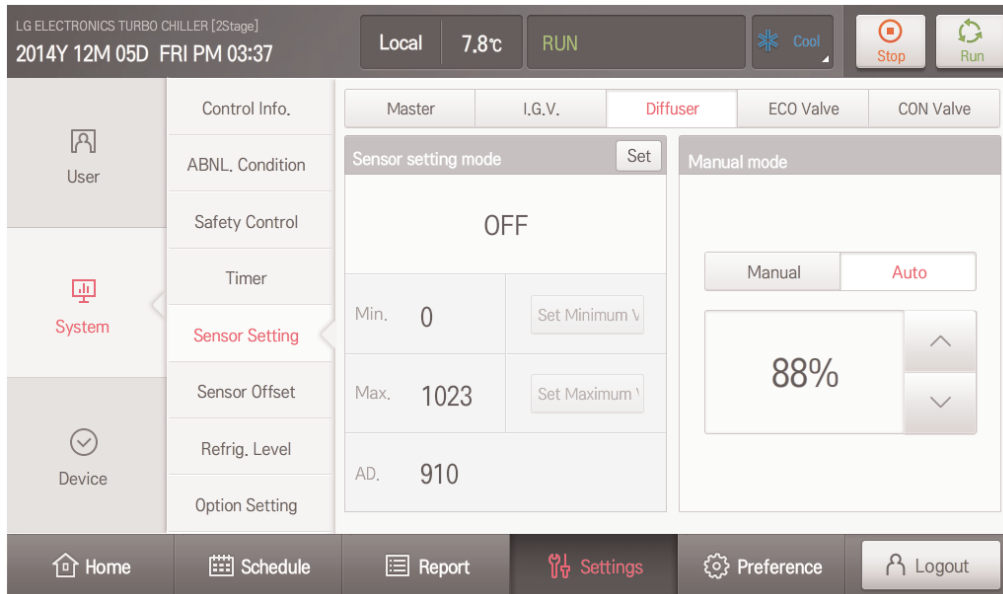

Figure 52. Sensor Setting Diffuser Vane

Item name	Setting availability	Setting UI	Unit	Minimum value	Maximum value	Adjustment Unit	Notes
Sensor setting mode	●	Select a list	-	-	-	-	ON/OFF
Manual/Automatic setting	●	Button	%	0	100	1	Manual/automatic
Diffuser Vane Minimum	●	Button	-	0	1023	-	(Available to use when the sensor setting mode is ON) Available to press the minimum button
Diffuser Vane Maximum	●	button	-	0	1023	-	(Available to use when the sensor setting mode is ON) Available to press the maximum button
Diffuser Vane AD value	-	-	-	0	1023	-	Monitoring

Table 33. Sensor Setting Diffuser Vane Items

5.2.5.4 ECO Valve

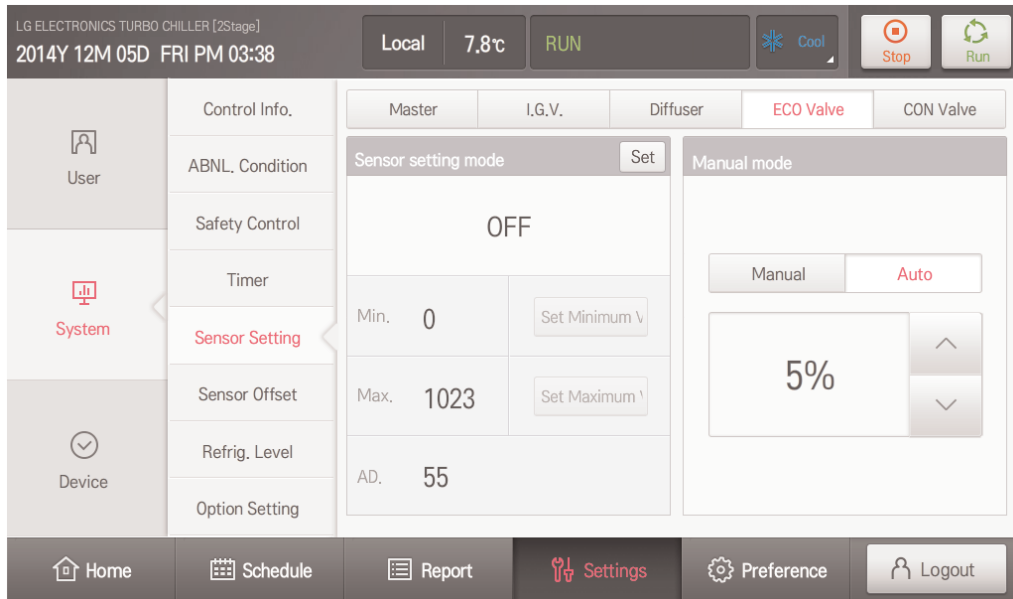

Figure 53. Sensor Setting ECO Valve

Item name	Setting availability	Setting UI	Unit	Minimum value	Maximum value	Adjustment Unit	Notes
Sensor Setting Mode	●	Select a list	-	-	-	-	ON/OFF
Manual/Automatic Setting	●	Button	%	0	100	1	Manual/Automatic
ECO Valve Minimum	●	Button	-	0	1023	-	(Available to use when the sensor setting mode is ON) Available to press the minimum button
ECO Valve Maximum	●	button	-	0	1023	-	(Available to use when the sensor setting mode is ON) Available to press the maximum button
ECO Valve AD value	-	-	-	0	1023	-	Monitoring

Table 34. Sensor Setting ECO Valve Items

5.2.5.5 CON Valve

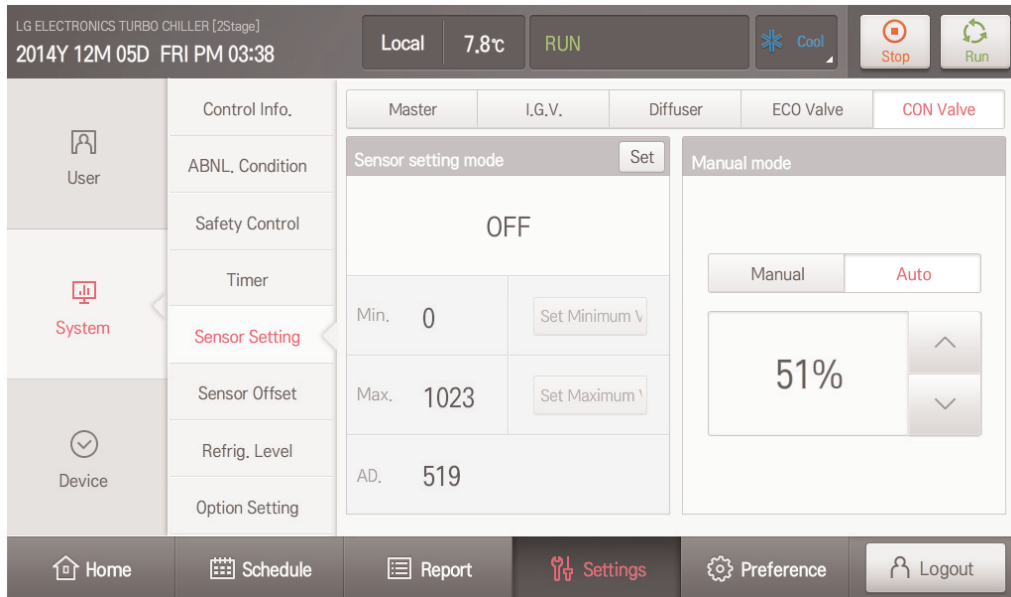

Figure 54. Sensor Setting CON valve

Item name	Setting availability	Setting UI	Unit	Minimum value	Maximum value	Adjustment Unit	Notes
Sensor Setting Mode	●	Select a list	-	-	-	-	ON/OFF
Manual/Automatic setting	●	Button	%	0	100	1	Manual/automatic
CON Valve Minimum	●	Button	-	0	1023	-	(Available to use when the sensor setting mode is ON) Available to press the minimum button
CON Valve Maximum	●	button	-	0	1023	-	(Available to use when the sensor setting mode is ON) Available to press the maximum button
CON Valve AD value	-	-	-	0	1023	-	Monitoring

Table 35. Sensor Setting CON Valve Item List

5.2.6 Sensor Offset

This is menu available for offset of each sensor value.

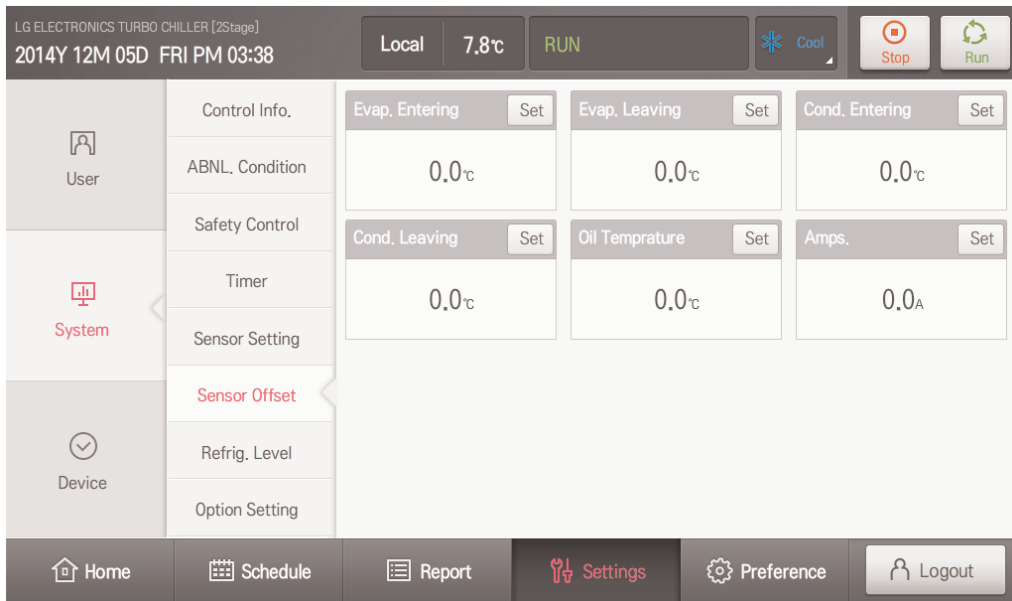

Figure 55. Sensor Offset

Item name	Setting availability	Setting UI	Unit	Minimum value	Maximum value	Adjustment Unit	Notes
Sensor Setting Mode	●	Select a list	-	-	-	-	ON/OFF
Manual/Automatic Setting	●	Button	%	0	100	1	Manual/Automatic
ECO Valve Minimum	●	Button	-	0	1023	-	(Available to use when the sensor setting mode is ON) Available to press the minimum button
ECO Valve Maximum	●	button	-	0	1023	-	(Available to use when the sensor setting mode is ON) Available to press the maximum button
ECO Valve AD value	-	-	-	0	1023	-	Monitoring

Table 36. Sensor Offset Item List

5.2.7 Refrigerant Level

5.2.7.1 ECO Refrigerant Level

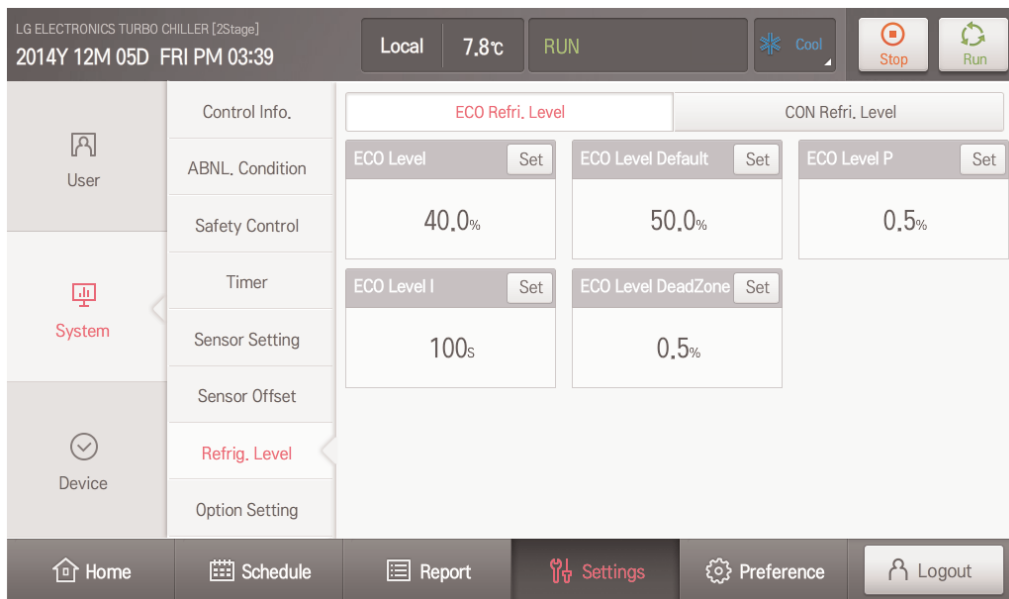

Figure 56. Refrigerant Level, ECO Refrigerant Level

Item name	Setting availability	Setting UI	Unit	Minimum value	Maximum value	Adjustment Unit	Notes
Sensor Setting Mode	●	Select a list	-	-	-	-	ON/OFF
Manual/Automatic setting	●	Button	%	0	100	1	Manual/automatic
CON Valve Minimum	●	Button	-	0	1023	-	(Available to use when the sensor setting mode is ON) Available to press the minimum button
CON Valve Maximum	●	button	-	0	1023	-	(Available to use when the sensor setting mode is ON) Available to press the maximum button
CON Valve AD value	-	-	-	0	1023	-	Monitoring

Table 37. Refrigerant Level, ECO Refrigerant Level Item List

5.2.7.2 CON Refrigerant Level

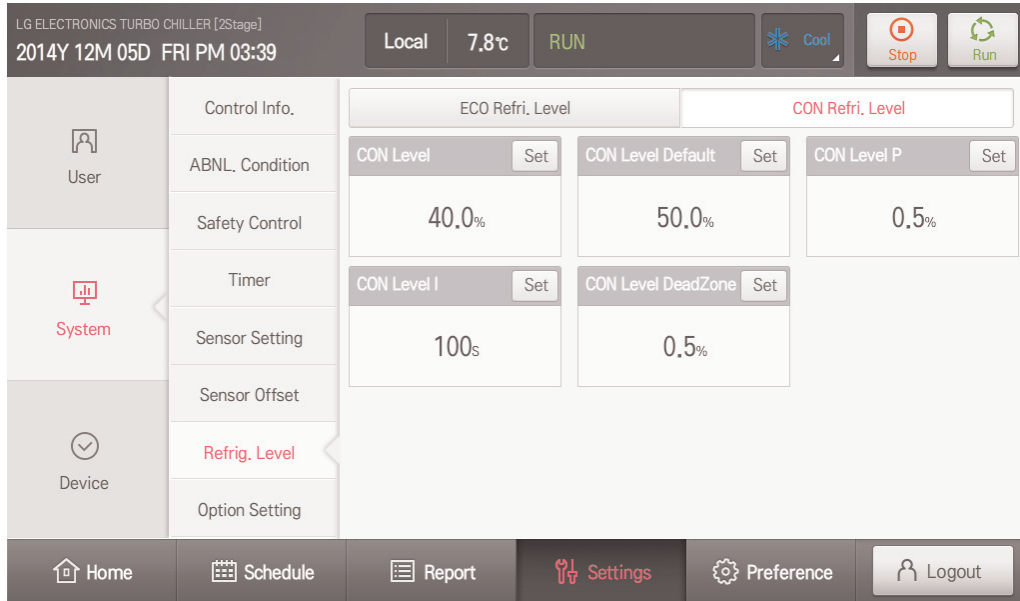

Figure 57. Refrigerant Level , CON Refrigerant Level

Item name	Setting availability	Setting UI	Unit	Minimum value	Maximum value	Adjustment Unit	Notes
CON Refrigerant Level Setting	●	Select a number	%	0	100	0.1	
CON Refrigerant Valve Default	●	Select a number	%	0	100	0.1	
CON Refrigerant Level P	●	Select a number	%	0	100	0.1	
CON Refrigerant Level I	●	Select a number	seconds	0	3600	1	
CON Refrigerant Dead Zone	●	Select a number	%	0	100	0.1	

Table 38. Refrigerant Level, CON Refrigerant Level Items

5.2.8 Option Setting

This is the menu to set to use/not use of the sensor.

5.2.8.1 Master

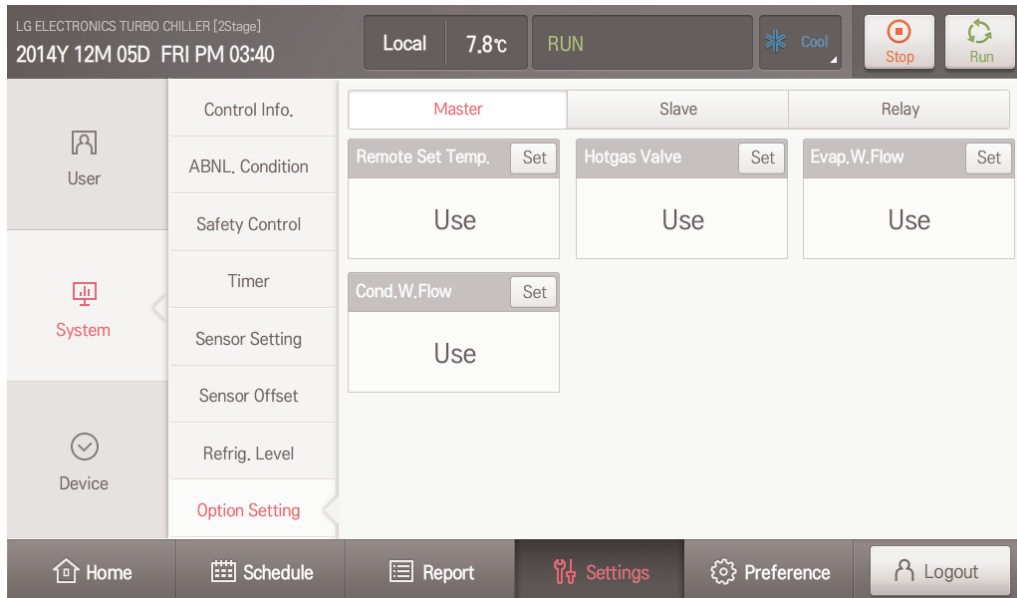

Figure 58. Option Setting Master

Item name	Setting availability	Setting UI	Unit	Minimum value	Maximum value	Adjustment Unit	Notes
Remote Setting Temperature	●	Select a list	-	-	-	-	Use/not use
Hot Gas Valve	●	Select a list	-	-	-	-	Use/not use
Evaporator Water Flow	●	Select a list	-	-	-	-	Use/not use
Condenser Water Flow	●	Select a list	-	-	-	-	Use/not use

Table 39. Option Setting Master Items

5.2.8.2 Slave

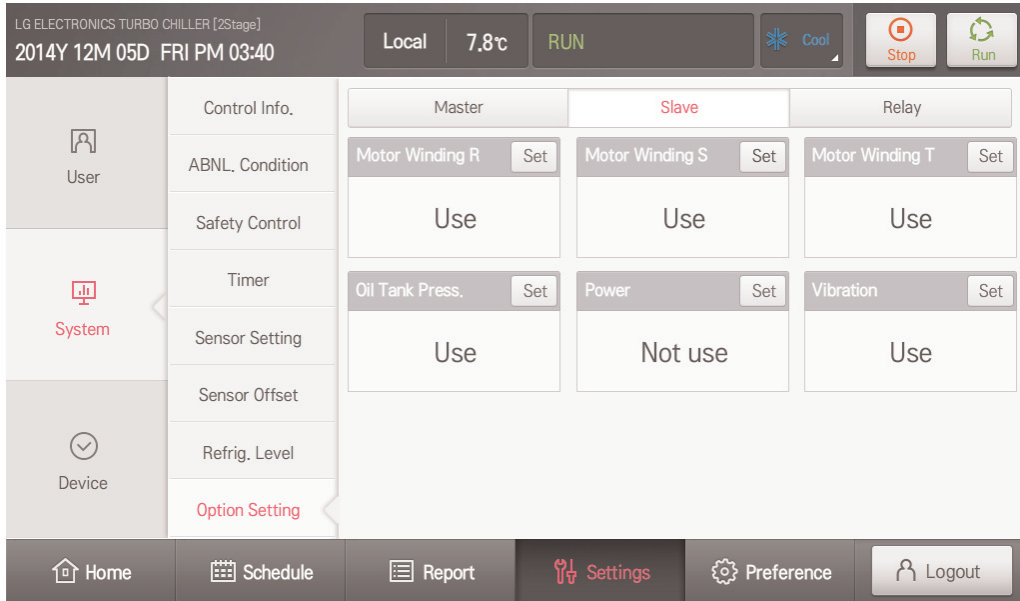

Figure 59. Option Setting Slave

Item name	Setting availability	Setting UI	Unit	Minimum value	Maximum value	Adjustment Unit	Notes
Motor Winding R temperature	●	Select a list	-	-	-	-	Use/not use
Motor Winding S temperature	●	Select a list	-	-	-	-	Use/not use
Motor Winding T temperature	●	Select a list	-	-	-	-	Use/not use
Oil Tank Pressure	●	Select a list	-	-	-	-	Use/not use
Power	●	Select a list	-	-	-	-	Use/not use
Vibration	●	Select a list	-	-	-	-	Use/not use

Table 40. Option Setting Slave Item List

5.2.8.3 Relay

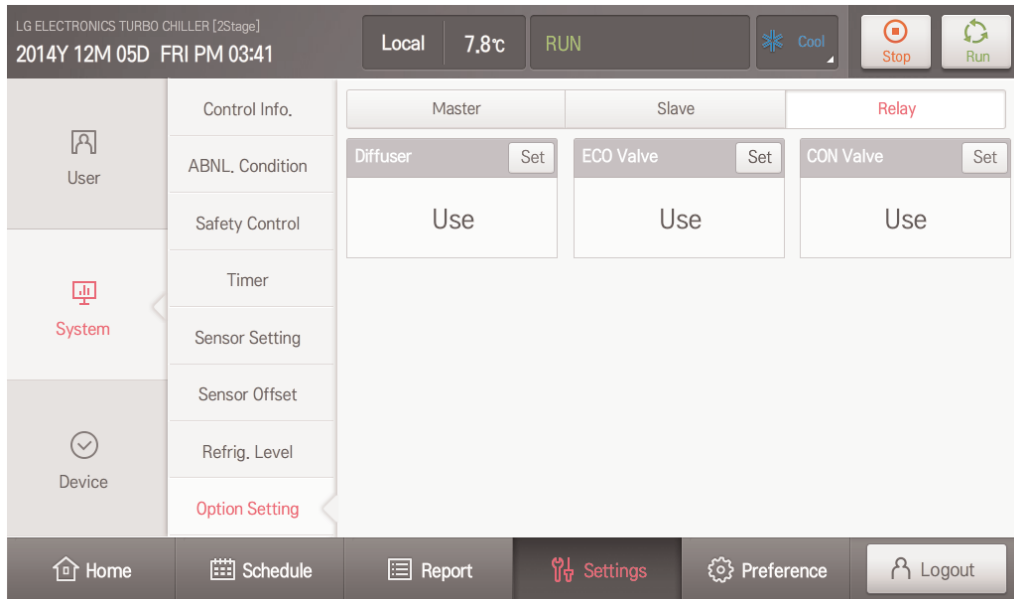

Figure 60. Option Setting Relay

Item name	Setting availability	Setting UI	Unit	Minimum value	Maximum value	Adjustment Unit	Notes
Diffuser Vane Sensor	●	Select a list	-	-	-	-	Use/not use
ECO Valve	●	Select a list	-	-	-	-	Use/not use
CON Valve	●	Select a list	-	-	-	-	Use/not use

Table 41. Option Setting Relay Item List

5-6. Environment Settings

This consists of the general settings, screen settings, customer settings, network settings, advance settings and channel settings. This is menu to set the HMI system.

6.1 General Setting

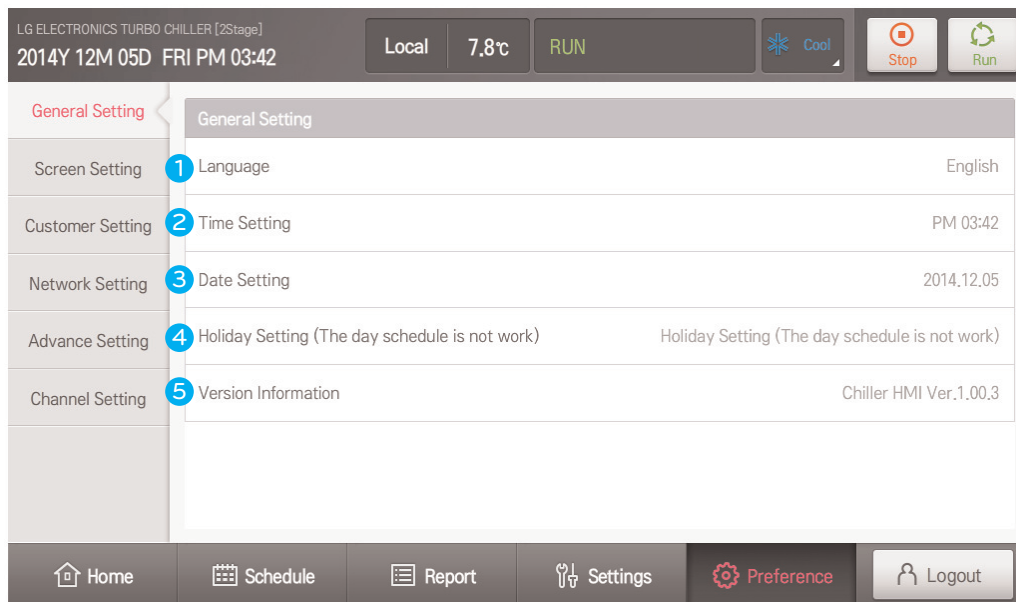

Figure 61. General Setting

No.	Component	Description
1	Language	Provides the evaporator animation. Provides lists of languages for setting (Korean/ English/Chinese).
2	Time Setting	Displays the time of the HMI system. Provides a setting list pop-up when selected.
3	Date Setting	Displays the date of the HMI system. Provides a time setting pop-up when selected.
4	Holiday Setting	Sets holidays that schedules do not work.
5	Version Information	Displays a version of the information of the HMI

Table 42. General Setting Items

6.1.1 Language Setting

Korean/English/Chinese settings are available.

1. Log in and press General Settings - Language.

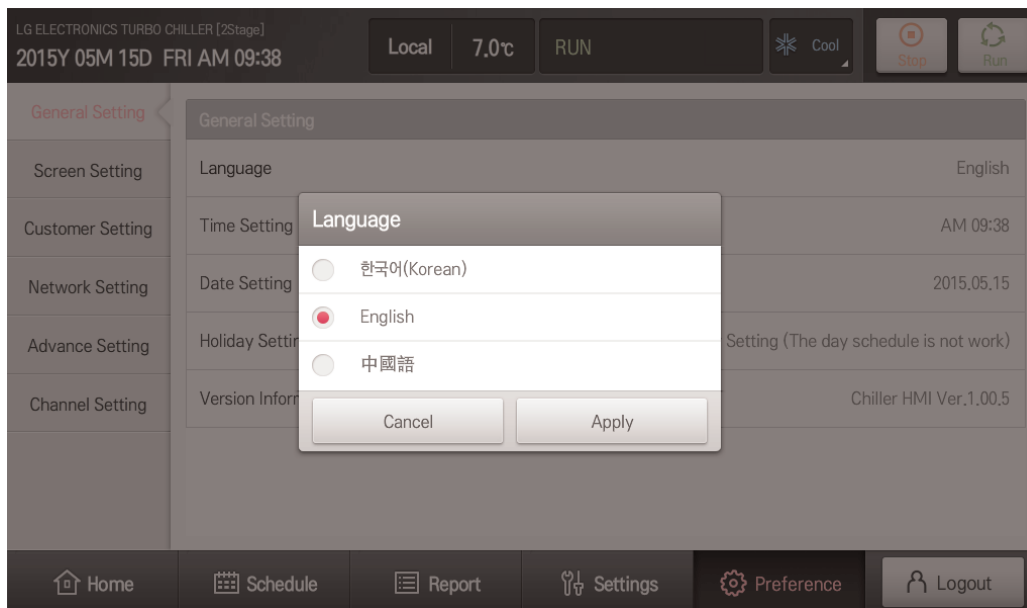

Figure 62. Language Selection List

2. Language change is completed by pressing "Apply" after selecting the desired language.



Figure 63. Language Setting → Korean



Figure 64. Language Setting → English



Figure 65. Language Setting → Chinese

6.2 Screen Settings

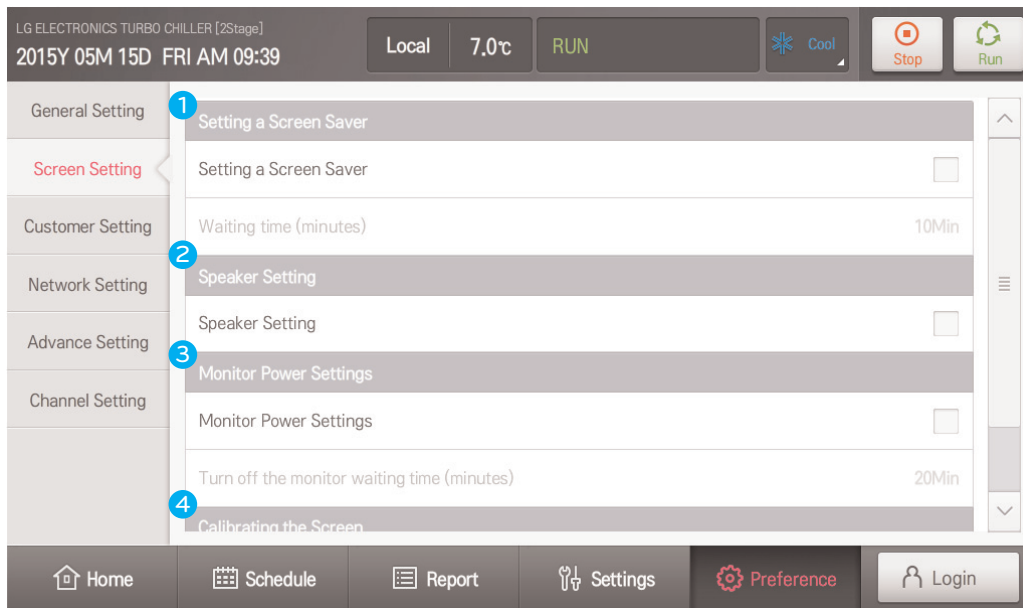

Figure 66. Screen Settings

No.	Component	Description
1	Screen Saver	Sets use/not use for the screen saver. Sets a waiting time with a list menu among 10, 20, 30, 40, 50 and 60 minutes.
2	Speaker Setting	Sets use/not use for the speaker.
3	Backlight Power Setting	Sets use/not use for the backlight. Sets a waiting time with a list menu among 10, 20, 30, 40, 50 and 60 minutes.
4	Screen Calibration	Screen calibration menu for accuracy of screen touch.

Table 43. Screen Setting Items

6.3 Customer Settings

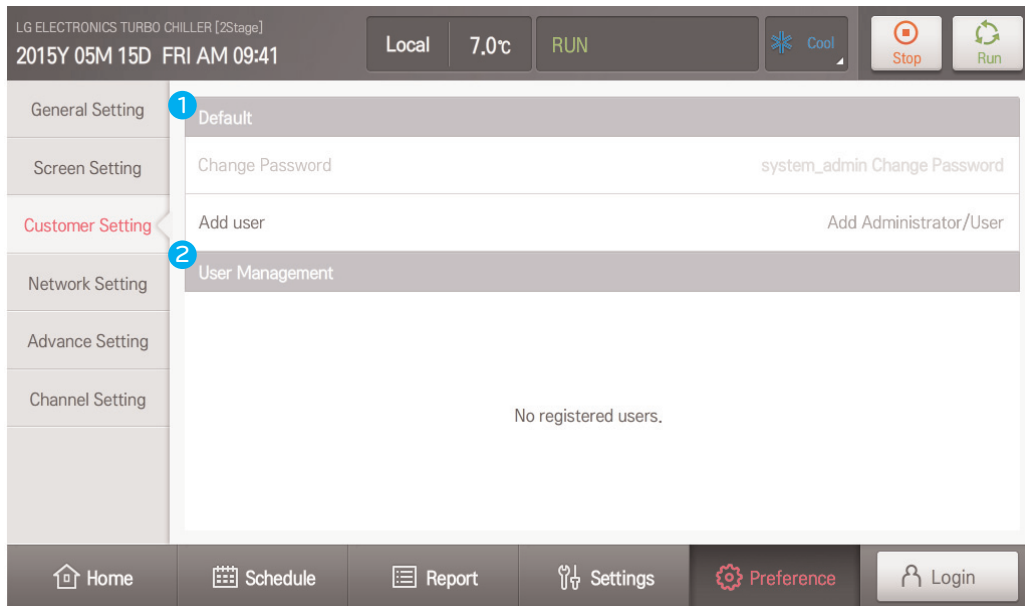

Figure 67. Customer Settings

No.	Component	Description
1	General Settings	Menu to change the password for currently logged in account and to add an administrator account.
2	User Management	Menu to delete or edit (change password) other administrator accounts.

Table 44. Customer Settings Item List

6.3.1 Administrator Account

1. Log in with the installer account.
2. Select Environment Settings - Customer Settings – Add User.

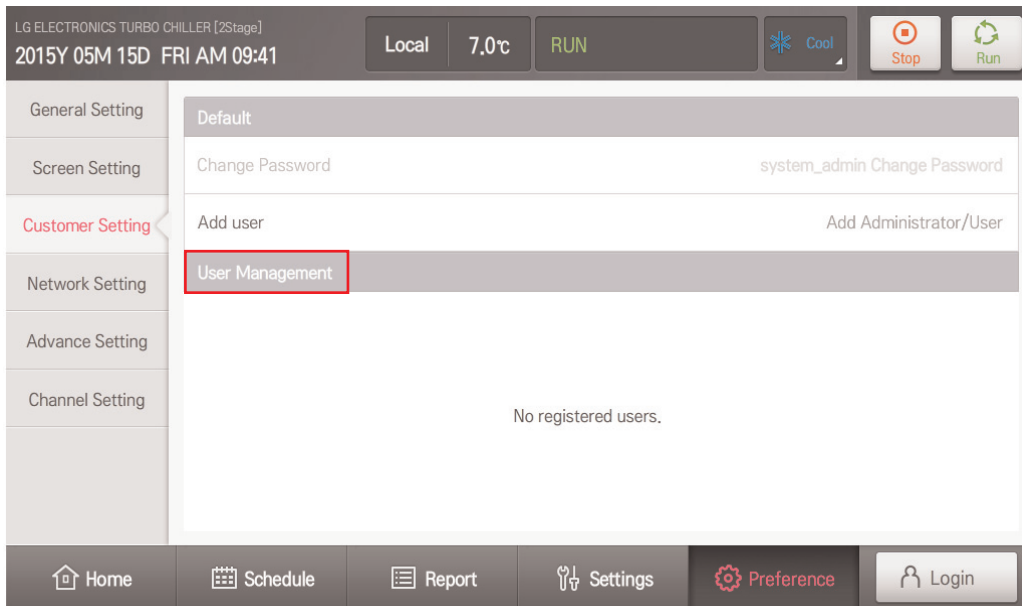

Figure 68. Add User

3. Enter ID/Password/Password Confirm in the “Add User” pop-up and press “Confirm” button.

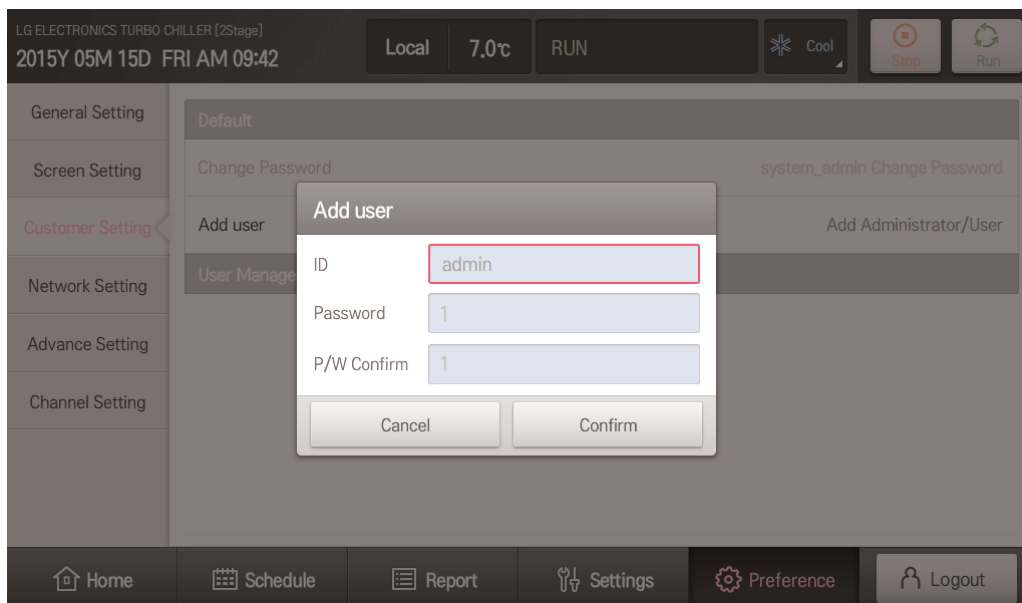

Figure 69. Add User Pop-Up

4. An “Administrator Account” with ID entered in the pop-up is created when pressing “Confirm” button.

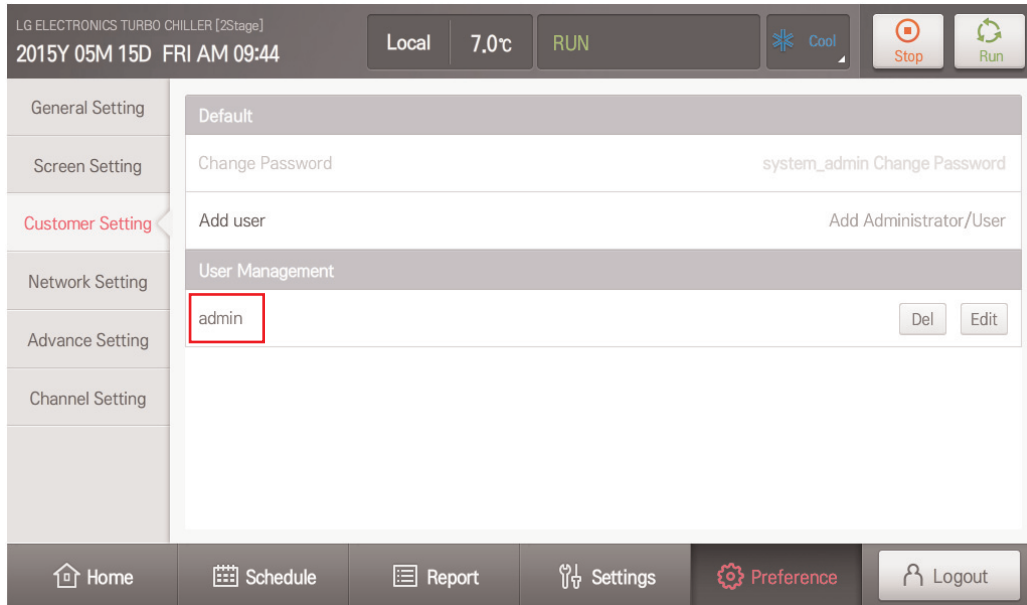

Figure 70. Administrator Account Creation

5. Log out and log in as the “Administrator account”

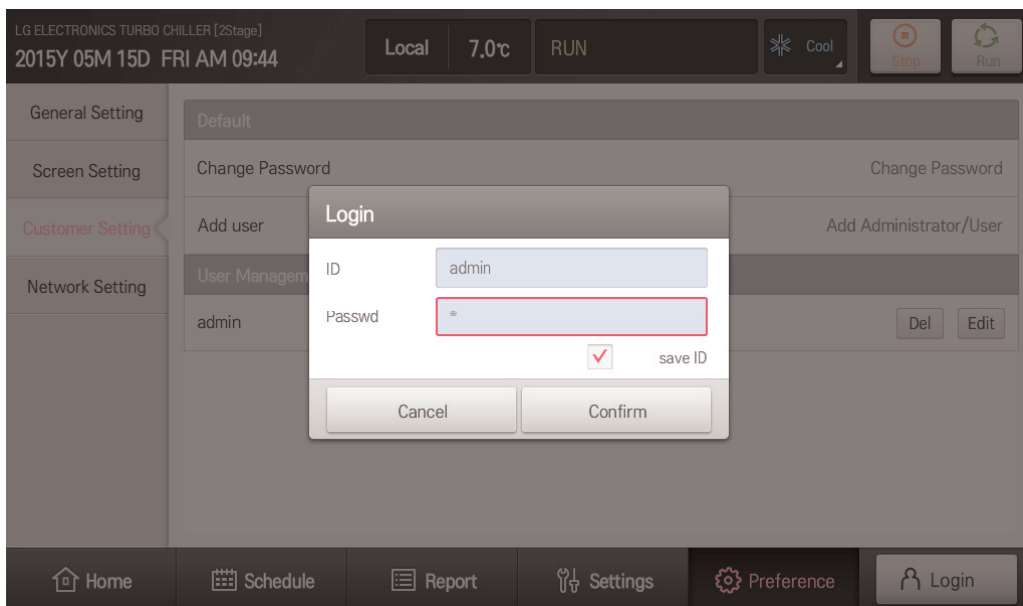

Figure 71. Log In

6.4 Network Settings

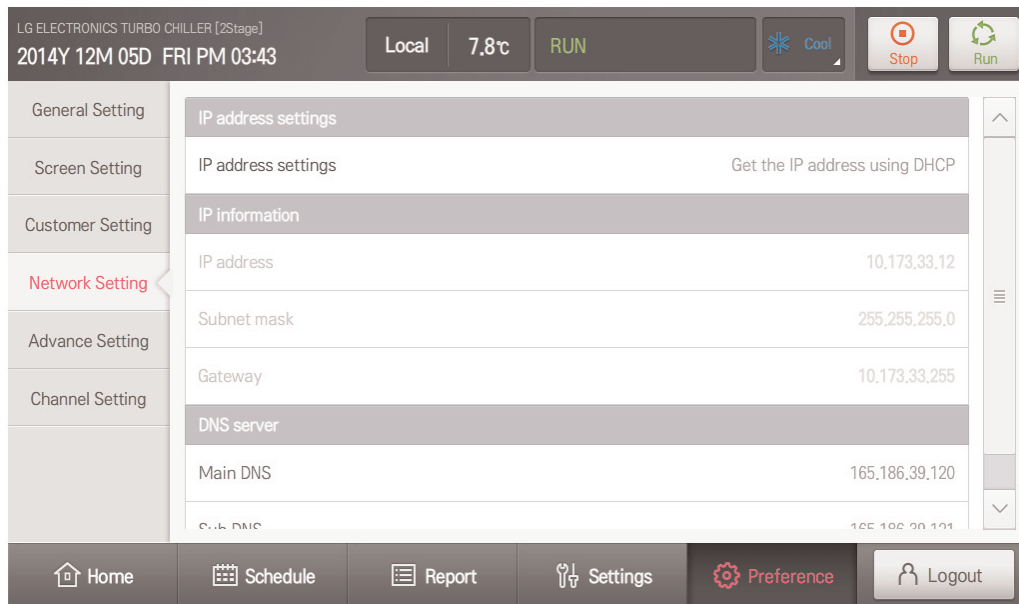

Figure 72. Network Settings

No.	Component	Description
1	IP Address Settings	Set an IP address setting method
2	IP Information	Enter IP address/subnet mask/gateway
3	DNS Server	Enter Main DNS Sub DNS

Table 45. Network Setting Item List

6.5. Advance Settings

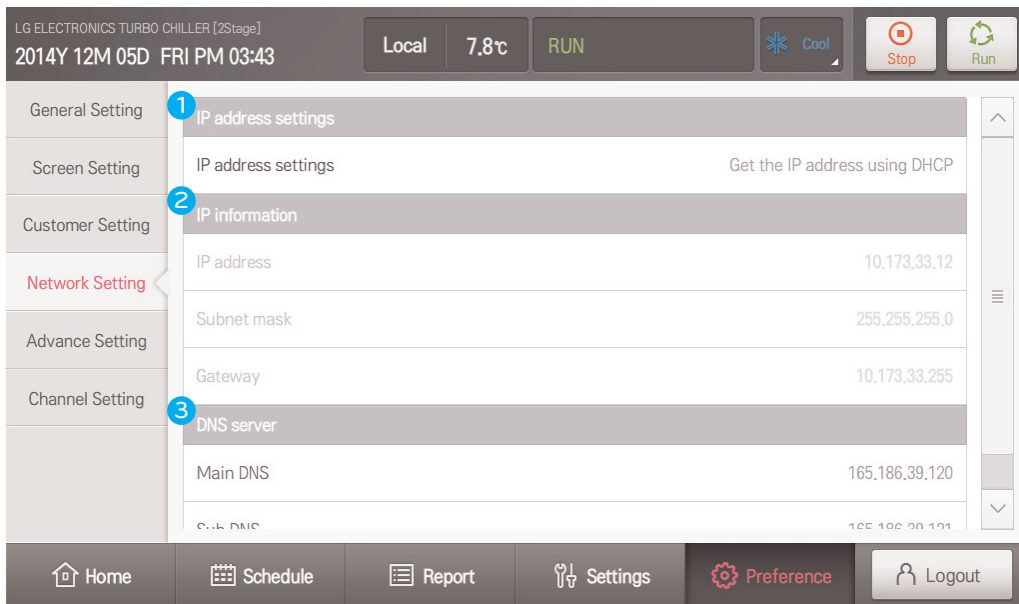

Figure 73. Advance Settings

No.	Component	Description
1	Set interlocking	Displays units applied to the HMI system. Provides an unit setting list pop-up when selected. Temperature Units: °C, °F Pressure Units: kgf/cm ² , kPa, psi Flow Units: m ³ /h, gal/min
2	Update S/W	Provides a function to upgrade the system to a new S/W when selected. (Only when SD CARD with a new S/W is inserted.)
3	DB management	Provides a function to manage DB that is used in the HMI system.

Table 46. Advance Settings Item List

6.6. Channel Settings

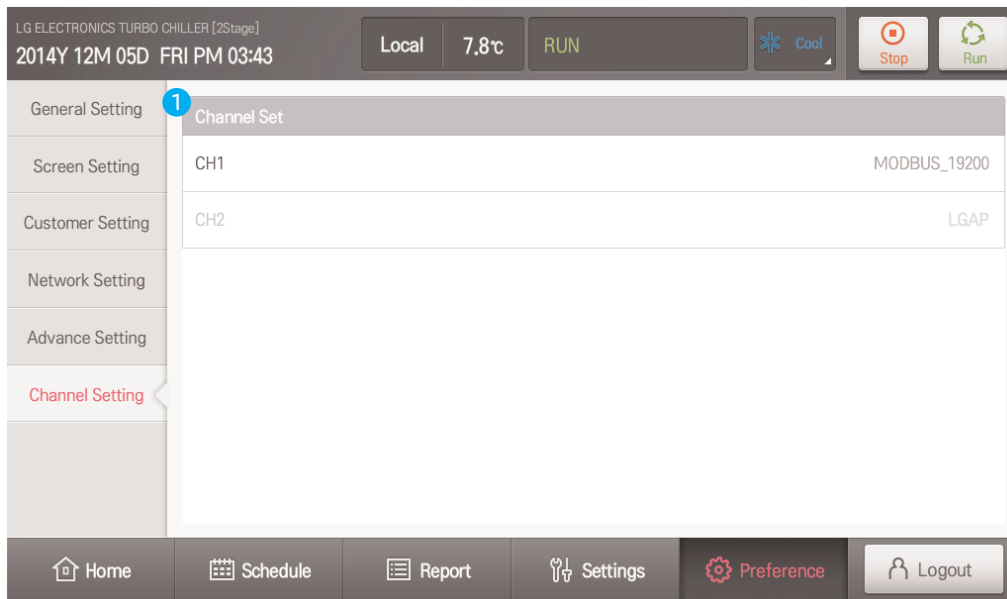

Figure 74. Channel Settings

No.	Component	Description
1	Channel Settings	Provides a function to set a communication speed of CH1/CH2. Communication speed: MODBUS_9600/ MODBUS_19200

Table 47. Channel Settings Item

5-7. Screen Saver

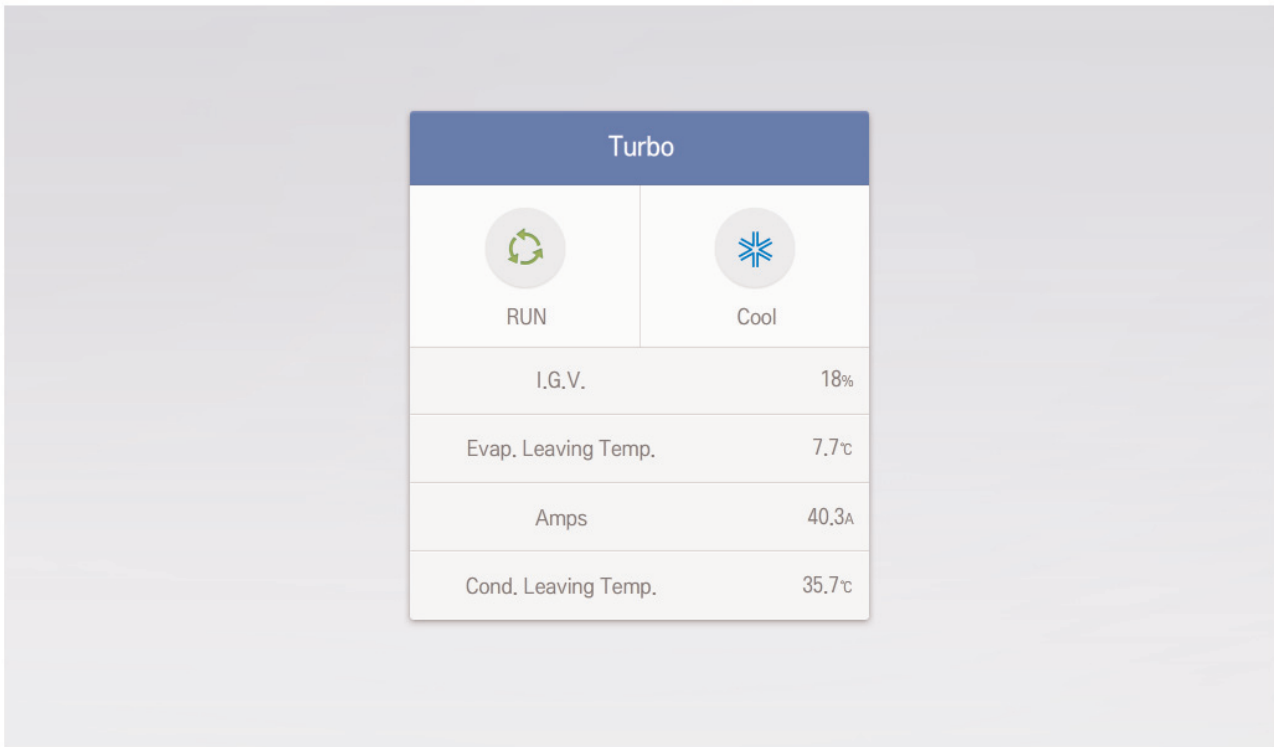

Figure 75. Screen Saver

No.	Component	Description
1	Screen Saver	Displays the device name/operation state/operation mode/vane opening/evaporator leaving temperature/motor current/condenser leaving temperature information.

Table 48. Screen Save Item

5-8. Data Storage

Component	Description
Data Storage	Generate important data in every 5 seconds. Compressed to Year_Month-Day.tar.gz(ex. 2013_01_01.tar.gz) form in a SD card.

Table 49. Data Storage Item

5-9. Web Function

This function monitors and controls the current status of the Chiller by remotely accessing it on the Web.

1. Connect LAN to HMI LAN port.
2. Select Environment Settings – Network Settings – IP Address Settings.

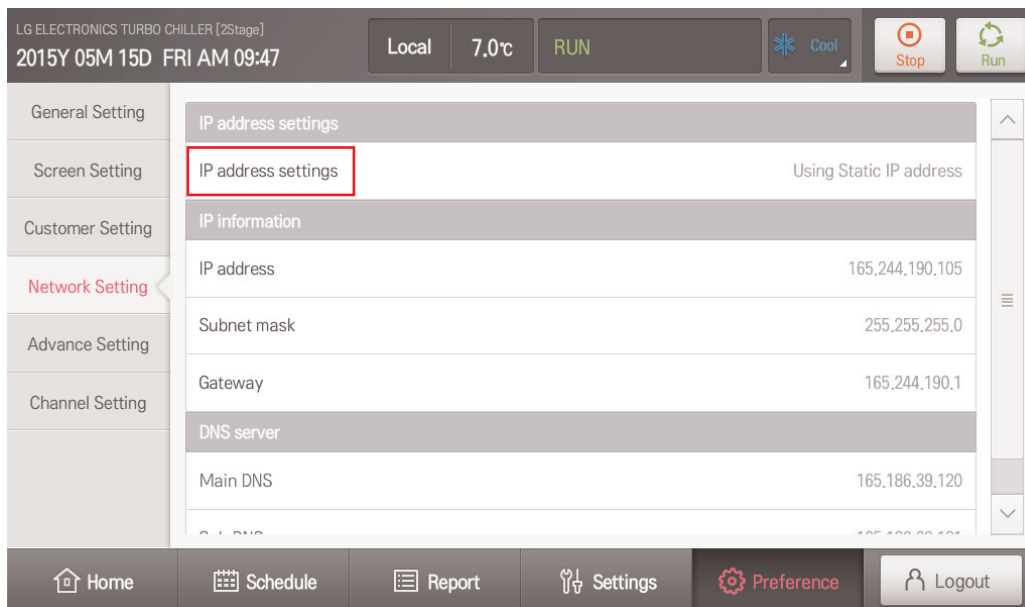

Figure 76. Network Settings

3. Press "Apply" button after selecting "Get the IP address using DHCP" in the "IP Address Setting Pop-up."

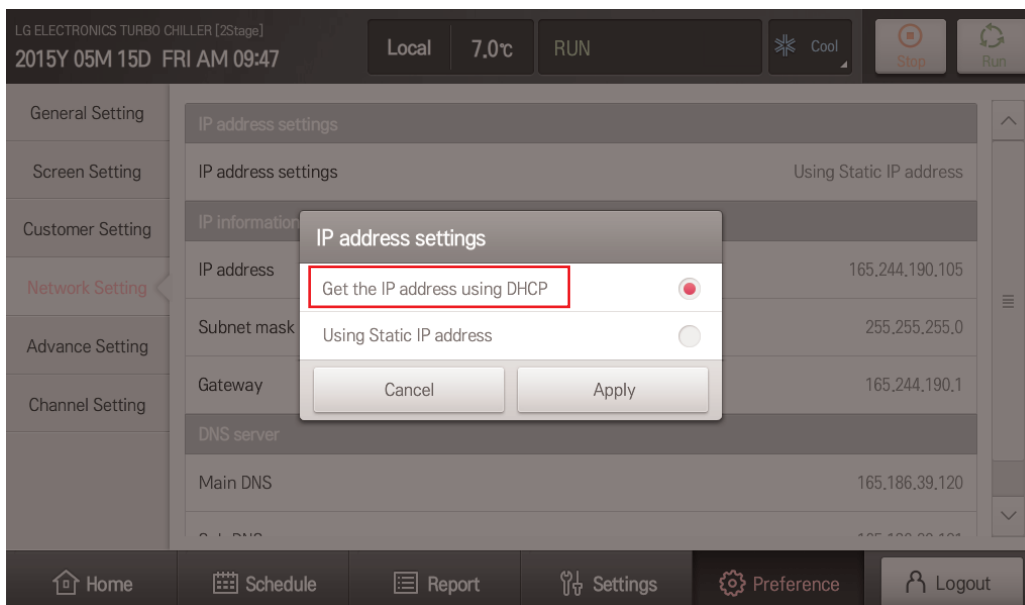

Figure 77. IP Address Settings

4. When the pop-up disappears, enter the IP address of the IP information in the Internet address bar in the form at <http://IPAddress>.

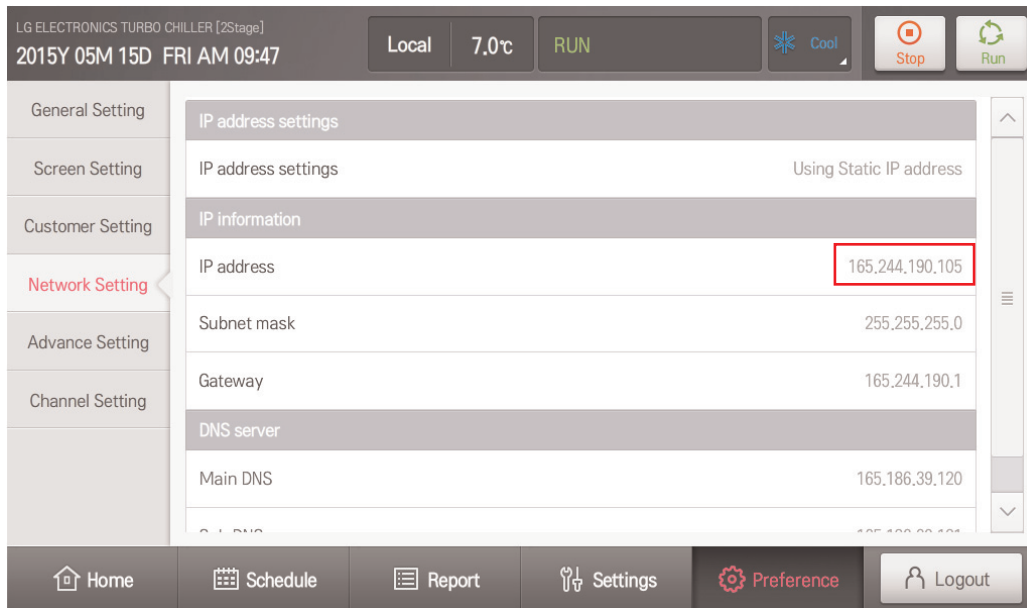

Figure 78. IP address of IP Information

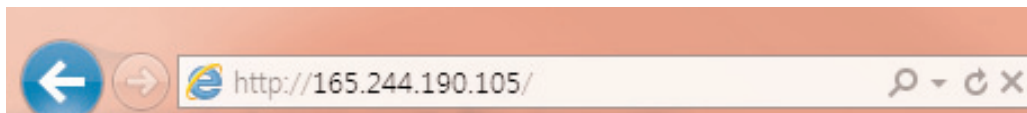

Figure 79. Enter IP address in the Internet Address Bar

5. HMI screen is displayed on the Web.

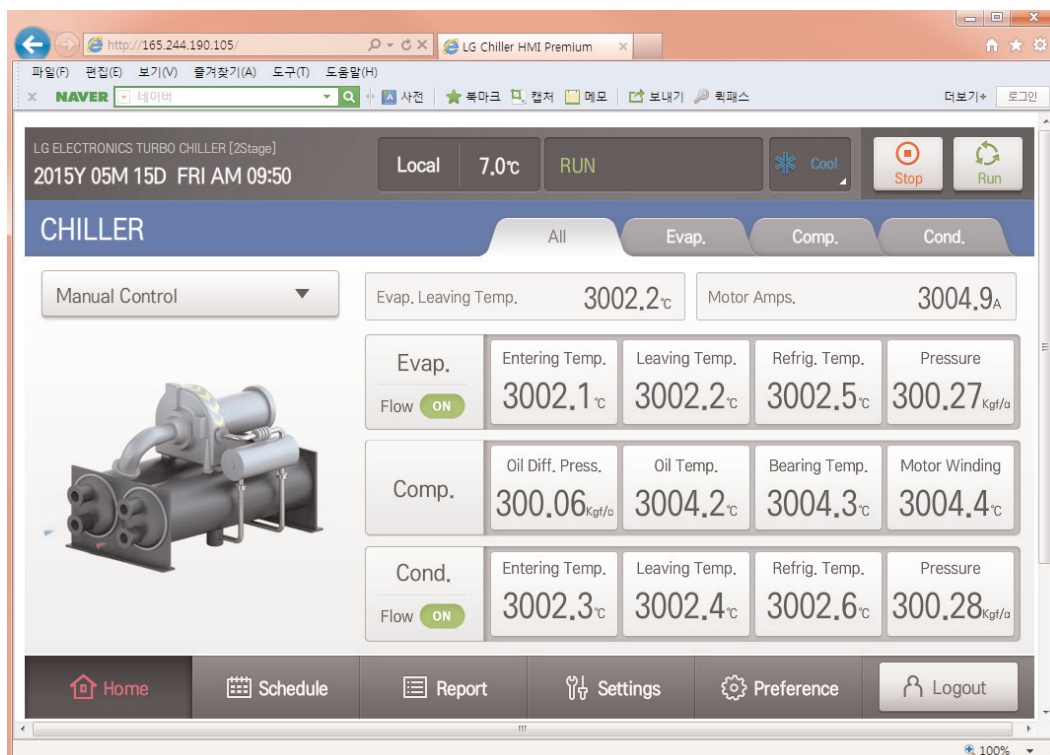
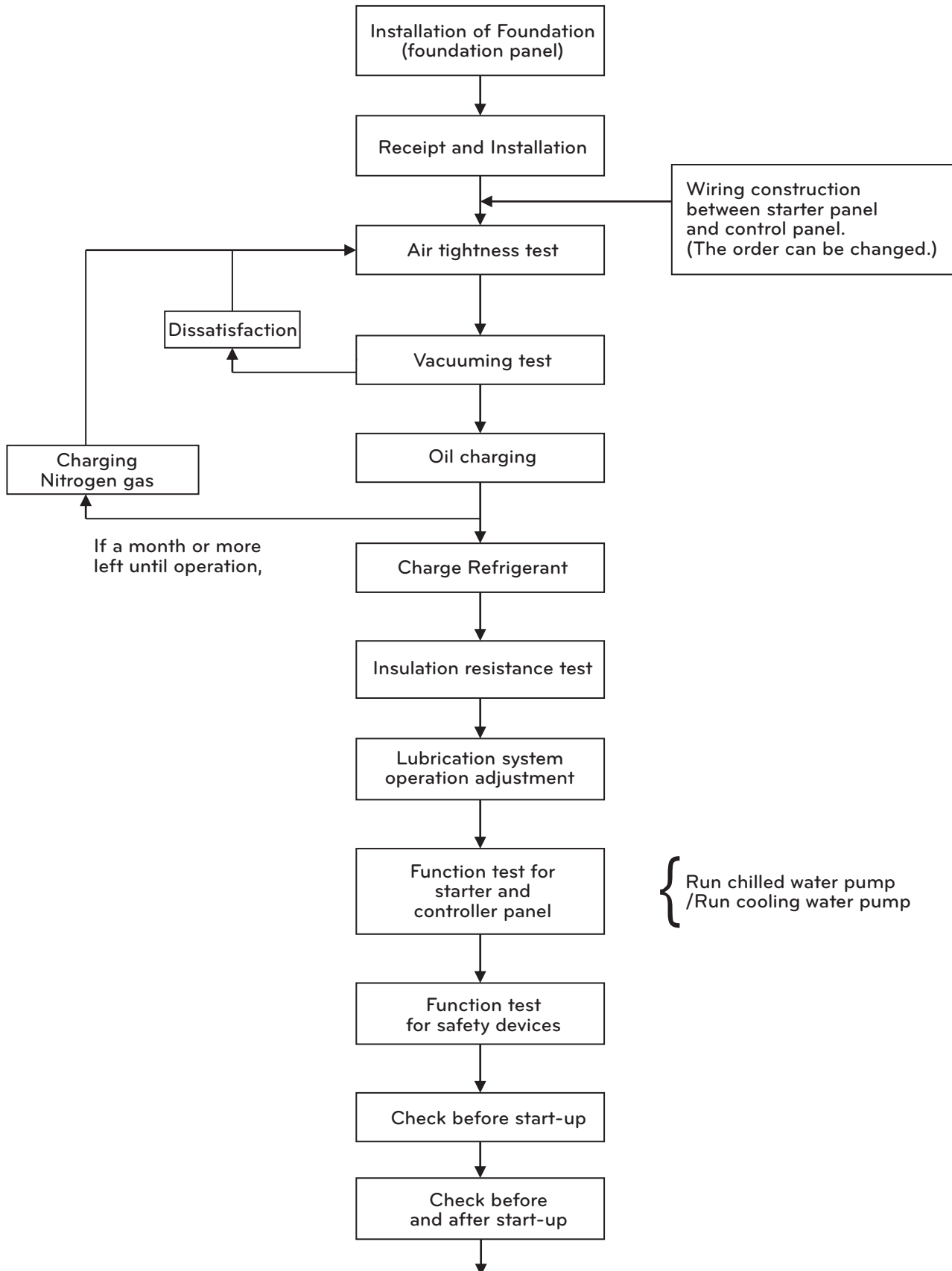

Figure 80. Web Access Screen

6. START-UP

6-1. Delivery and Installation Check

From Receipt, Installation to Startup



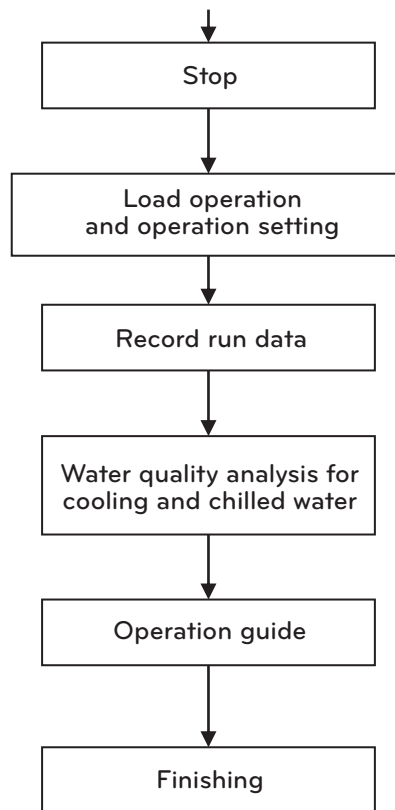

Figure 81. From receipt to Startup

Selecting a location

- If the chiller has to be installed near heat generating devices, keep distances more than 5 meters from boilers and hot-air blowers, and more than 2 meters from other heat generating devices.
- Choose a well-ventilated place and avoid place with high temperature.
- Choose a place with less humid.
- Provide ample space for service (for control and maintenance of pipes and tubes)

Foundation

- Build the foundation to withstand the concentrated heavy weight of the chiller.
- The foundation should be higher than the surface of the water, and install the drainage around.
- Be sure to install the drain pipe to the drainage hole.

Receipt and Installation

- The chiller should be installed evenly leveled to the ground.
- Install the chiller on a foundation with flat support surfaces, level within ± 1 mm with the manufacturer-supplied isolation pad assemblies under the unit.
- Make sure the foundation surface is flat and leveled within ± 1 mm using a level, and if not, readjust it within: ± 1 mm, using spacers.

6-2. Preparation for start-up

Preparation for start-up

- It is called start-up run that the first run after receipt and installation or the run after long-term stoppage (over 1 month) before the regular operation of the chiller.
- Preparation for start-up is the maintenance and repairing work at least once a year after installation, which is a very basic and important task.

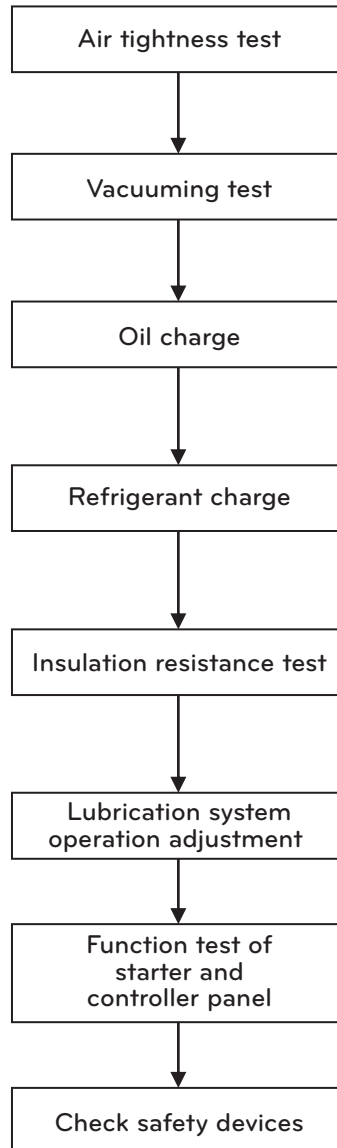

Figure 82. Preparation procedure for start-up

Checking the leak parts

It is recommended to perform leakage test following the steps in Fig 58. Refer to the temperature and pressure values of the refrigerant in Table 18.

Leakage Inspection

- The condition that requires the leak test
 - After the chiller is disassembled and repaired,
 - If the nitrogen's pressure charged in factory was lower during the transportation before the initial start-up:

- Weak Points for leak:
 - Parts where the gasket is used
 - Nut tighten part, bolt and nut
 - Copper tube connecting part
 - Sight-glass welded part
 - Compressor motor terminal

Inspection method

- 1) Charge the nitrogen in order until the internal pressure of the machine reaches 2 kg/cm², 5 kg/cm², 9~9.5 kg/cm².
- 2) Perform the soapy water test on every connecting part.
- 3) If the inspected pressure lasts for more than 30 min., prepare to do the soapy water test for smaller parts.
- 4) Mark the leaking point.
- 5) Eject the inner pressure of the machine.
- 6) Fix all the leaking points.
- 7) Do leak test again on the repaired points
- 8) After performing the large leaking test, increase the inner pressure up to the value of 9~9.5 kg/cm².
- 9) Do the small leak test and fix them all.
- 10) After the leak test is finished, exhaust the nitrogen gas very carefully.

* Please close the valve of evaporator, as when you increase the pressure inside of the chiller, the relief valve on the evaporator may get open.

Note: Open the relief valve on the condenser by 1.05 Mpa (10.71 kg/cm²).
The relief valve on the evaporator open at 0.99 Mpa (10.1 kg/cm²)

Temperature °C	Pressure 1kg/cm ²	Temperature °C	Pressure 1kg/cm ²	Temperature °C	Pressure 1kg/cm ²
-26.18	0	15	3.9517	51	12.740
-20	0.3255	16	4.1136	52	13.087
-19	0.3850	17	4.2793	53	13.400
-18	0.4465	18	4.4491	54	13.800
-17	0.5101	19	4.6230	55	14.167
-16	0.5758	20	4.6230	56	14.540
-15	0.6437	21	4.9932	57	14.921
-14	0.7138	22	5.1697	58	15.308
-13	0.7862	23	5.3605	59	15.703
-12	0.8610	24	5.5558	60	16.104
-11	0.9381	25	5.7555	61	16.513
-10	1.0176	26	5.9597	62	16.929
-9	1.0996	27	6.1685	63	17.353
-8	1.1841	28	6.3819	64	17.784
-7	1.2713	29	6.6001	65	18.223
-6	1.3610	30	6.8231	66	18.670
-5	1.4535	31	7.0510	67	19.124
-4	1.5486	32	7.2838	68	19.587
-3	1.6466	33	7.5216	69	20.057
-2	1.7474	34	7.7644	70	20.536
-1	1.8512	35	8.0124	71	21.023
0	1.9579	36	8.2657	72	21.518
1	2.0675	37	8.5242	73	22.023
2	2.1803	38	8.788	74	22.535
3	2.2962	39	9.0578	75	23.057
4	2.4153	40	9.3318	76	23.587
5	2.5376	41	9.6128	77	24.127
6	2.6632	42	9.8988	78	24.676
7	2.7922	43	10.190	79	25.234
8	2.9246	44	10.488	80	25.802
9	3.0604	45	10.791	81	26.379
10	3.1998	46	11.101	82	26.966
11	3.3428	47	11.416	83	27.563
12	3.4894	48	11.738	84	28.171
13	3.6397	49	12.066	85	28.788
14	3.7938	50	12.400	86	29.417

Table 50. HFC-134a Temperature / Pressure

Vacuum Dry & Vacuum Test

- The vacuum dry work has to be taken to eliminate the humidity when the machine is exposed to the atmospheric air for a long time or it is indicated that the moisture got into the machine or complete pressure loss of refrigerant happened due to refrigerant leak.



WARNING

Do not operated the compressor motor or the oil pump motor, and do not take any insulation resistance test when performing the vacuum dry work.

Even instant rotation for rotation check-up can damage the electrical insulation and cause huge damage.

- Generally the vacuum dry work is performed at a room temperature. The higher the room temperature is, the faster the vacuum dry performance will be done. Stronger vacuum quality is required to evaporate the moist in the environment of lower room temperature. The vacuum dry working procedure is as follows.
 - 1) Connect the high capacity vacuum pump (Approximately above 120 LPM) to the refrigerant charge valve. The length of the pipe from the pump to the machine should be as short as possible and the diameter of the pipe as big as possible for minimum gas flow resistance.
 - 2) To measure the vacuum, if the pressure gauge is installed or pressure value from MICOM is available, the pressure gauge may be used.
 - 3) When vacuuming work, open all the valves except the valves connected to external.
 - 4) Allow approximately 2 hours of additional vacuum pump operation, if the surrounding temperature of the machine is above 15.6 °C, and while the vacuum pump is operated if the manometer is indicating 756mmHg. If the internal pressure of the chiller is kept below 756 mmHg, the accumulated moist in the machine would be frozen and then this ice is evaporated more slowly than in normal condition, which leads to a delay of the vacuum dry work. If there is hot water at this situation, let the evaporator and the condenser be flowed by the hot water and then operate the vacuum pump.
 - 5) Fasten the vacuum pump valve and stop the pump, and then record the vacuum gauge value. When reading the degree of the vacuum while the surrounding temperature varies, it has to be compensated by converting the temperature change into pressure using below equation.

$$\Delta P + (760 + H) \times \left[\frac{t_2}{273 + t_2} - \frac{t_1}{273 + t_1} \right] \text{ mmHg}$$

H: Internal pressure before the inspection (mmHg)

t1: Surrounding temp. before the inspection (°C)

t2: Surrounding temp. after the inspection (°C)

Table 51. HFC-134a Temperature / Pressure

- 6) The vacuum dry work is terminated if there is no change in the vacuum gauge value after waiting for 4 hours. The machine is well air-tight if the leak rate is below 0.1 mmHg/h(=0.1 Torr/h). If the vacuum gauge value rose up, repeat step 4) and 5).
- 7) If the value still changes after several time of vacuum dry work, set the inner machine pressure above 9~9.5kg/cm².G and perform the leak inspection. After fixing the part where it is leaking, redo the vacuum dry work.

Oil charge

- 1) Generally the chiller is charged with the oil in the compressor when shipping from the manufacturer, but if not, follow the steps as described below.
- 2) Charge the oil through the charging valve located at the bottom of the oil tank. At this time, make the inner part of the machine vacuum using a vacuum pump. (If the refrigerant charging is proceeded, the charged refrigerant will evaporate and eventually the pressure will rise. Thus, do the oil charging first.) If the inner machine pressure is high, use the pump from the tank for the charging. In this case, the Discharging pressure of the pump shall be more than 14 kg/cm².G when the suction pressure is 0kg/cm².G. The oil charging or removal, however, must be done at the condition that the chiller is totally stopped.
- 3) The oil level must be charged more than 2/3 of the sight glass. Also if only the oil pressure and the temperature are within the designated range, oil foaming may be happening.
- 4) Be cautious not to let any air enter into during oil charging.

Refrigerant charge



CAUTION

When the refrigerant charging or discharging is performed on a machine that uses springs for isolation at the bottom, fix the springs not to move up and down. The spring moving may stress the connected pipe line.

- 1) The chiller is charged with nitrogen gas when leaving from the factory. Remove the nitrogen gas at the job-site before doing the refrigerant charging.
- 2) Operate the chilled and cooling water pump to prevent freezing when performing the refrigerant charging.
- 3) It is the most preferable to adjust the refrigerant charge amount when the Chiller is operated under the design load. Adjust the amount of refrigerant by the difference between chilled water outlet temperature and evaporation temperature and through the sight glass.

Insulation resistance test

- 1) Mega test is to apply the direct voltage to the insulation material to obtain insulation resistance by measuring the leaking current through the material.

$$\text{Insulation resistance} = \frac{\text{Leak Current}}{\text{Applied Voltage}}$$

For 3000 and 6000V class: use mega for 1000V.

For 380 and 440V class: use mega for 500V.

- 2) Keep away any unnecessary personnel during the test for it is using high voltage.
- 3) Cut all the exterior power that is supplied to the chiller before performing the test. The 3-phase motor that is for above 500hp, can cause danger due to the electric charge when the inspection was performed. Thus, completely discharge it after the inspection and then handle the ground terminal.
- 5) Do not perform the high voltage mega test in vacuum condition.
- 6) Electrical insulation resistance drops in accordance with the temperature increases, and is sensitive to the temperature change which means that it varies. The changed temperature can be written in temperature coefficient and the temperature coefficient and applied equation is as follows.

Insulation Resistance in inspecting (°C)	Temperature coefficient	Insulation Resistance in inspecting (°C)	Temperature coefficient
0	0.4	40	2.50
5	0.5	45	3.15
10	0.63	50	3.98
15.6	0.81	55	5.00
20	1.00	60	6.30
25	1.25	65	7.90
30	1.58	70	10.00
35	2.00	75	12.60

Table 52. Temperature coefficient under insulation temperature

- 7) Other factors that influence the insulation resistance
 <Pollution of the outer surface of the insulation body> If absorptive and deliquescent materials like acid, chloride and etc are adhered on the surface of the insulation body, they influence the insulation resistance. Remove the foreign substances before the inspection. <Condensing Point> If the insulation body temperature is below the surrounding temperature's dew point, moisture condensation can be preset on the insulation body surface (especially at the crack and the groove) and influence the insulation resistance. The inspection should be taken into action when the insulation body temperature is above the surrounding temperature's dew point. Record the dry bulb and the wet bulb temperature surrounding air. <Absolute Humidity> Even through the insulation body temperature is above the dew point, the atmospheric vapor influences insulation resistance. Avoid conduction test at the place where the absolute humidity is high present.
- 8) Apply an electric current for a minute to the spot to be measured up insulation resistance. Read and record the value. Apply the inspection standard when the insulation body temperature is 20 °C. (When measured at a different temperature, use the temperature coefficient and convert the value indicated after a minute.)
- 9) Taking measures according to insulated condition.

Temp. of insulation body at inspection (°C)	Value indicated after a minute	Action
Danger	Below 2 MΩ	Repair or Exchange
Bad	Below 50 MΩ	Troubleshooting
Re-inspection	50~ 100 MΩ	Troubleshooting
Good	100~500 MΩ	
Better	500~1000 MΩ	
Excellent	Above 1000 MΩ	

* Motor that is within the range of "Bad" and "Re-Inspection" at the mega insulation test, must take the POLARIZATION INDEX test.

Table 53. Insulation condition

10) Polarization Index Test

Record the indicated value appeared when performing the mega test after a minute and the one after 10 minutes.

$$\text{Insulation Inhaling rate} = \frac{\text{indicated value after 10 minutes}}{\text{indicated value after 1 minute}}$$

Condition	Insulation Absorption Rate
Danger	Below 1
Bad	Below 1,5
Re-Inspection	1.5~2
Good	2~3
Better	3~4
Excellent	Above 4

If the motor's insulation absorption rate is within the range of "Danger", must be returned or replaced.

If the motor's insulation absorption rate is above the range of "Bad", must be checked additionally after 4 hours of careful operation.

Table 54. Insulation absorption rate status

11) The following should be recorded when performing the mega test

- Type and voltage of the mega tester
- Connection part of the mega tester
- Surrounding temperature and humidity of the test taking place and the tank's internal pressure in case of hermetic type
- Stoppage period before the inspection

Function test for starter and controller panel

- Test before the Start-up
 1. Control Panel and Electric lines

Cut the power and check the controlling parts and switches for any foreign substances. Also check for normal operation and terminal connection conditions by handling the switches.
 2. Voltage

Check if the voltage indicated at the voltage meter of the starter panel is identical to the rated voltage on the chiller name plate.
 3. Chilled and cooling water circulation system

Check if the chilled and cooling water operation is depicted properly on the display by activating individual pump.

- Control Device Operation Test
 1. Check the wiring condition

Check whether the wiring of power, sensor, etc. are properly connected.
Special checking should be taken to power line.
 2. Check the display condition after control power in

Be more cautious if there is any symptom of getting short for 5 seconds after the power is in.
If problem occurs, immediately cut the power and check for abnormality.
 3. Check values displayed on the panel

Check if the display indicating sensor values are normal.
If the sensor indicates abnormal or error message is displayed, check the connection of the sensors.
 4. No power operation

While the power of the main motor is cut, operate and check whether the operation is normal up to the Starter panel operation signal. If a message displayed for abnormality, check the part.

- Check of Safety Device

Flow operation test for chilled water and cooling water

 - Close the valves located at the pipe of the chilled and cooling water, and check whether the differential pressure switches for flowing are working properly or not.

6-3. Start-up

- After the preparation is done for start-up, proceed as follows.

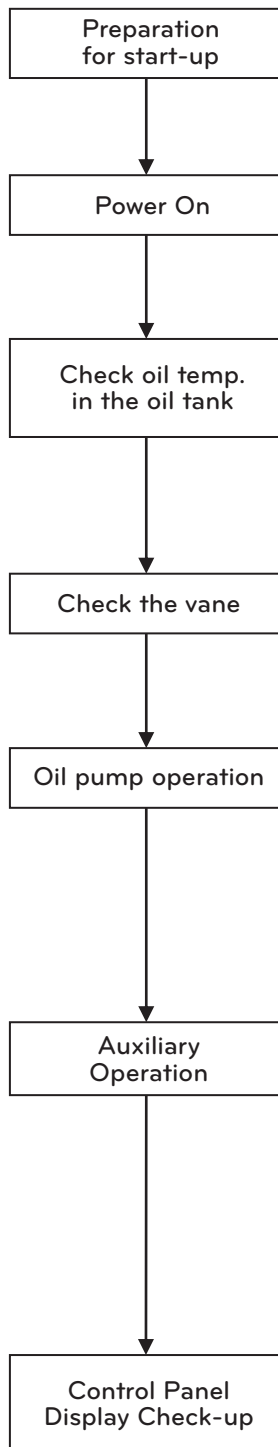

- 1) Input power to the control panel and the starter panel, and check the status.
- 2) Input power to the oil heater 1~2 hours prior to the main operation and make sure that the temperature of the oil inside the tank is 30~65°C.
- 3) After checking the vane opening as 0%, set the vane's operation to "Auto". The vane is to maintain 0% on any condition of "Auto", "Open", "Stop", "Closed" when the chiller stops.
- 4) Set the oil pump condition of the control panel to "Auto".
- 5) Activate the chilled water pump. When operating, close the outlet valve, open the air ventilation valve and then open the outlet valve to a small carefully to avoid water hammering so that necessary amount of flow passes through. If water keeps coming out after the air discharged through the air outlet, close the air valve.
- 6) Activate the cooling water pump. Caution required just as step 5).
- 7) Check the control panel display if it is working properly. Check if the display is showing local operation mode and chiller's possible operation condition.

Figure 83. Start-up procedure

- If the chiller is working under Local Operation Mode, follow the steps as follows. If strange situation is detected, shut down the chiller immediately and follow the "troubleshooting" procedure. For more detailed information, refer to the "Check list".

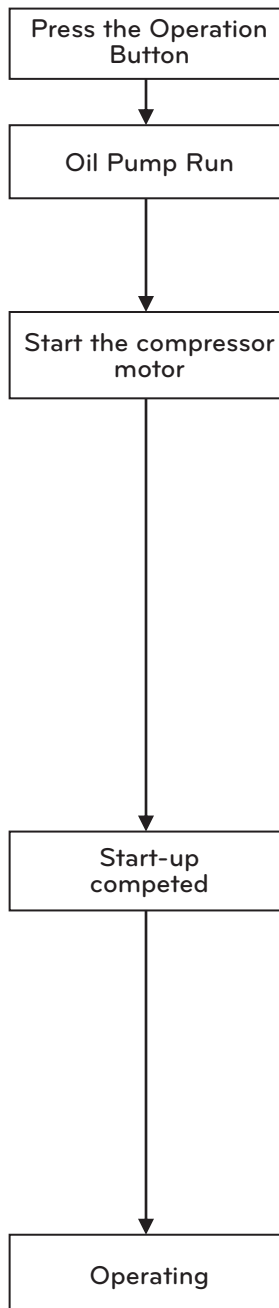

- 1) Checking the oil pressure
When the operation button on the control panel is pressed, oil pump will be activated that leads to an increase in the oil pressure and if the differential pressure between supplying oil to the bearing and the inner tank oil lasts for 120~180 sec. over 0.8 kg/cm², the compressor motor will be operated.
- 2) Direction of the compressor motor's rotation.
- 3) Starting characteristic
At this time, 2 items check-up is needed simultaneously. Make sure 2 people are working together.
 - Direction of the motor's rotation
Record the rotating direction at the counter load part of the motor. If the direction is opposite, stop the chiller and change the two among three phases.
 - Starting Characteristic
Check the starting current, acceleration completion time as on the "Check List".
- 4) Check the Operating Current
- 5) Motor Cooling Status
 - Operating Current
After the start-up is done, the vane will be opened gradually and the current increases simultaneously. Operation current should not exceed the rated current. If exceeds, set it referring to the "capacity control module."
 - Motor Cooling Status
Periodic physical check-up of the motor surface temperature is required while operation.
 - Checking the oil tank and the bearing temperature
Check if the oil tank and the bearing temperature is preserved at 40~65°C. If not refer to "Trouble Shooting" and "Check List".
- 6) Checking all sorts of pressure status
- 7) Checking the operating sound and vibration
- 8) Chilled-water inlet and outlet temperature
- 9) Cooling-water inlet and outlet temperature

Figure 84. Start-up procedure (2)

- Load Operation and the Operational Setup

After the Start and the Stoppage operation, perform the Load Operation as follows.

In any cases, let do not exceed the electromotor rated current.

As mentioned already at the "Product Protection Function", it would not be able to be overloaded due to the set of the motor current limiting function, but please double check.

Set the temperature control function according to the load.

Set the user's setting function as mentioned already in the "Product Protection Function".

When performing automatic operation

Set the vane operation mode to auto

1) In case of load increasing

To preserve the chilled water outlet temperature, the guide vane is opened up to the electromotor rated current.

2) When the load is parallel with present performance of the chiller

The guide vane is stopped at a certain degree of opening.

3) In case of load decreasing

- In opposition to 1), to preserve the chilled water temperature the guide vane is close.

- When the load is continuously decreased, the chilled water outlet temperature will be decreased and the chiller will be stopped by the function of "Chiller operation/stoppage". If the chilled water outlet temperature increases to the level of setup temperature, it will be operated automatically.

- The oil pump will perform additional operation even after the chiller's shut down.

The purpose of this action is to preserve the oil pressure (for inertia operation of about 1 min. after the chiller shut down) and to protect the electromotor from frequent start and stoppage.

6-4. Startup procedure after long-period of stoppage

When letting the chiller to be still for a long period of stoppage, the refrigerant must be transferred to a separate refrigerant pot to prevent machine pressure decrease and leak.

Charge approximately 5kg of refrigerant into the machine to prevent air-entrance.

If the installed area of the chiller is frequently a place of below zero, drain the chilled water, cooling water and the condensing water to prevent freezing. Also waterbox drain must be opened.

Leave the oil in the machine and supply heater power to maintain minimum oil tank temperature.

Before operating the centrifugal chiller after long-period of stoppage (longer than 1 month) or instant stoppage (less than a month), follow the next steps.

1. The machine should be checked for unstable part or for abnormality for smooth operation.
2. To prevent refrigerant loss due to leak during the stoppage, following steps must be taken.
 - 1) Compressor (simple inspection over the rotating part)
 - * Simply check from the appearance of the impeller, bearing and rotating part.
 - ◇ Combination status of the impeller and the shaft
 - ◇ Assemble condition of the Gear
 - ◇ Foreign substance in the gear box
 - ◇ End play of the impeller shaft
 - ◇ Assemble condition of the guide vane
 - ◇ Check the vane and the drive shaft
 - ◇ Check the gap between the impeller and the cover with a thickness gauge
 - 2) Lubrication system
 - ◇ Loosen and crack of the oil pipe
 - ◇ Replacing or clearing the oil filter
 - ◇ Cleaning the oil tank
 - ◇ Replacing the oil
 - 3) Refrigeration System
 - ◇ Check the refrigerant pollution possibility
 - ◇ Clean the ejector
 - ◇ Clean the tube
 - ◇ Water quality analysis
 - ◇ Exchange or clean filter related parts
 - 4) Condenser, Evaporator Preservation (Corrosion countermeasures while stoppage)

During a long term period stoppage, follow the next steps for the corrosion countermeasures due to condenser and evaporator tube corrosion.

 - Each tube should be brushed and the scales must be removed completely. Fill it in with clean water. Finally preserve it with rustic proof material in it.
 - In principle preserve the chiller without water after complete drain.
 - Execute all regular maintenance check-up and the inspection for the operation system with care. Controlling test should be taken before the main operation.

If the compressor oil indicates an abnormal high-level display, there are possibilities that the oil absorbed the refrigerant.
3. Start the machine in accordance with "Start-up" after checking the 1~2 items.

6-5. System Shutdown

- When stopping the product, perform it in the following order.

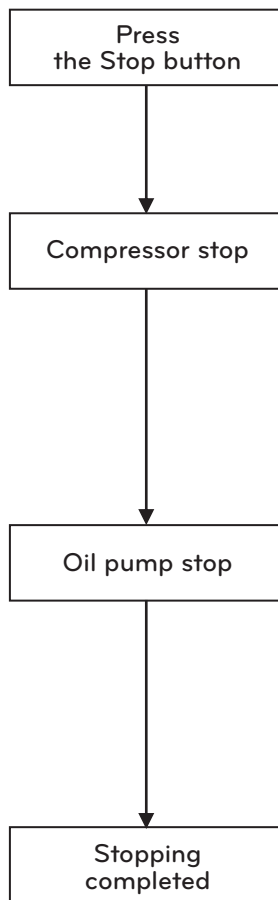

- 1) The vane is automatically closed when the stop button on the control panel is pressed.
- 2) Check the compressor motor stoppage time
 - Measure the delay time to the compressor's mechanical stop after the chiller's shutdown; the delay time due to motor's inertia moment.
- 3) Check the oil pump remaining operation
 - Check if the oil pump is operating till a resolved time after the chiller's shut down.
- 4) Checklist after stoppage
 - Stop the cooling water pump.
In this case, close the outlet valve of the pump gradually and then stop the cooling water pump.
 - Stop the chilled water pump.
Close the outlet valve of the pump gradually and then stop the chilled water pump.
 - Record the oil and the refrigerant level after stop.

Figure 85. Stopping Procedure

7. MAINTENANCE

7-1. Maintenance criteria

Maintenance and overhaul inspection (repairs)

- Usage Deterioration of Machine

Although there may not be any malfunction or structural deformation of the machine, it generally can be worn or aged after a long time usage. Though a centrifugal chiller which has been operated for a long time is operating, the motor can be declined and abrasion of the rotating section due to the secondary creation caused by oil burning, carbonization and etc. In many cases, such symptoms can normally be detected externally by the vibration and abnormal sounds that are present. In these cases, it is very important to take preventive action prior to the occurrence of accident and maintain a proper working condition for the sake of the machine's longer life.

- Examination and thorough overhaul (Repair)

The trouble ratio of a machine is normally distributed as the following Fig.

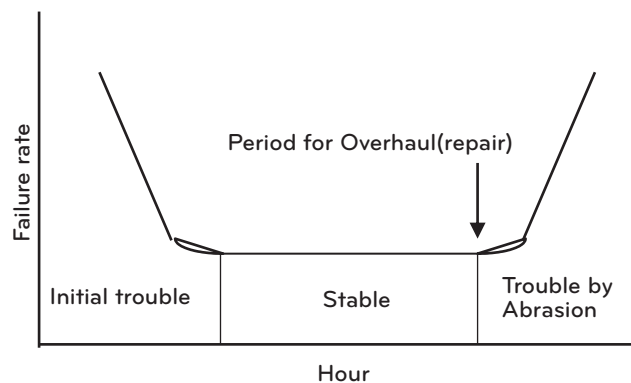

Figure 86. Machine failure rate

<Period of Initial Failure> occurs at the beginning stage of the machine's operation due to the manufacturing matter from the factory itself.

Then it enters the <Period of Stabilization> that is followed by the <Period of Abrasion> after a certain period of time. If it enters to the <Period of Abrasion> region, possibility of the machine's failure is going to rise up. Thus, it is very essential to take thorough overhaul (repairing) action will prevent accidents and allow an optimum maintenance.

We recommend on the basis of a long term experience and statistical data that you take the thorough overhaul (repairing) action at the following period.

1) Chiller for commercial cooling : Every 5 years

2) If is an industrial process machine that is working throughout the whole year and requires a high reliance: Annually

- Criteria for Overhaul

Accidents may take place if there are irresistible abrasion and deformation that leap over the assigned limit of the machine's individual parts.

For instance, if the bearing wears out, the destroyed oil film will cause the metallic contact to happen, which will lead to a high possibility of the bearing burning out.

The impeller itself might be able to have a contact with other parts and be destroyed. If the central distance of the velocity increasing gear leaps over a certain number, teeth of gear could also be destroyed.

Thus LG Electronics sets up (1) Utilization Limit (2) Exchanging Standards and based on these criteria, "Thorough Overhaul Procedure" was made to maintain the chiller under proper operating condition till next overhaul period, and according to this standard, composing parts can be inspected and replaced.

- Merits of the Maintenance Contract System

- (1) Economic Efficiency

- Deterioration of machine can be minimized by a regular maintenance action.
- As machine life is prolonged, the possibility of huge accident is reduced, which can save maintenance cost.
- As the contract is performed based on yearly predetermined cost, the effective management over the budget of the maintenance cost can be possible.
In order to prevent an unexpected cost caused by a sudden breakdown a counseling service with the customer is provided in advance.
- Opportunity loss of customer's production process resulted from the unexpected stop of machine can be eliminated.

- (2) Safeness

- Through checking a lot of safety devices, safe use of the machine without trouble can be possible.
- As a regular inspection is applied before trouble, breakdown is prevented beforehand.
- In case of maintenance contract, as training is provided, operator's management skill over the machine is developed.

- (3) Quickness

- As machine status can be always checked through a regular inspection, precise instruction can be given to even a trouble notice by phone call.
- Maintenance Contract machines will get the premium service as the first creditor even during the rush season when there are plenty of service loads.

Maintenance Contract Work Details (Standard)

1. Inspection before the start cooling

- | | |
|---|---|
| (1) Air-tightness Test | (5) Function test between Starter panel ~ Control panel |
| (2) Refrigerant charging | (6) Vacuuming |
| (3) Electricity related insulation test | (7) Chiller operation setup |
| (4) Safety device setting | |

2. Maintenance during the cooling period (1 time)

- (1) Electricity related insulation test
- (2) Checking the operation Setup
- (3) Chiller operation setup

3. After finishing cooling season

- | | |
|-------------------------------------|--|
| (1) Refrigerant full extraction | (8) Air tightness test |
| (2) Nitrogen gas charging & sealing | (9) Electricity-relate insulation test |
| (3) Filter checking(Replacing) | (10) Function test between Starter panel ~ Control panel |
| (4) Cleaning oil tank | (11) Checking the oil pump |
| (5) Checking the operation record | (12) Chiller operation setup |
| (6) Checking sensors (Replacing) | |
| (7) Picking Oil | |

4. Water quality analysis (1 time)

- Chiller for Annual Operation

1. Check-up during the Operation period (5 time)

- (1) Electricity related insulation test
- (2) Inspection the operation record
- (3) Chiller operation setup

2. Overall Maintenance (once)

- | | |
|-------------------------------------|--|
| (1) Refrigerant full extraction | (8) Air tightness test |
| (2) Nitrogen gas charging & sealing | (9) Electricity-relate insulation test |
| (3) Filter inspection (Replacing) | (10) Function test between Starter panel ~ Control panel |
| (4) Cleaning oil tank | (11) Checking the oil pump |
| (5) Checking the operation record | (12) Chiller operation setup |
| (6) Checking sensors (Replacing) | |
| (7) Oil extraction | |

3. Water quality analysis

- Standard Maintenance Frequency

- (1) Chiller for Cooling only; Cooling Start x 1, During operation x 1, Cooling Completion x 1
- (2) Chiller for Annual Operation : During Operation x 5, Overall Maintenance x 1

- Excluded Items

- (1) Cleaning the Heat Exchanger
- (2) Overhaul(repair)
- (3) Items that are not listed in the contract

Overhaul(repair)

- Compressor

1. Compressor Overhaul(repair)

- | | |
|---|-------------------------------|
| (1) Preparation | (6) Inspecting Impeller shaft |
| (2) Disassemble Compressor | (7) Assemble Compressor |
| (3) Check capacity controlling device | (8) Check Flow rate |
| (4) Inspection over the Compressor parts and cleaning | (9) Putting parts |
| (5) High-speed gear inspection | (10) Cleaning |

2. Auxiliary Work

- | | |
|-------------------------------------|---|
| (1) Air-tightness Test | (9) Electricity-relate insulation test |
| (2) Vacuum drying | (10) Checking the Oil pump |
| (3) Nitrogen gas charging & sealing | (11) Inspect and control over the safety device |
| (4) Full extraction of Refrigerant | (12) Starter panel ~ Control panel operating test |
| (5) Refrigerant charging | (13) Chiller operation setup |
| (6) Extraction of the Oil | (14) Check over the operation record |
| (7) Cleaning the Oil tank | |
| (8) Inspect the Filter types | |

- Motor

1. Motor overhaul (repair)

- | | |
|---|---|
| (1) Check Stator coil and rotor | (5) Gear disassemble and assemble |
| (2) Check the Parts | (6) Electricity wiring disassemble and assemble |
| (3) Measure Shaft Vibration, Concentricity degree | (7) Insulation Resistance Measurement |
| (4) Air gap, End Play measurement | (8) Winding Resistance measurement |

2. Auxiliary works

- (1) Refrigerant , Oil pipe Disassemble and Assemble

- Standard Contract Disassemble Inspection(Repairing) Parts

1. Compressor

- | | |
|--|--------------------|
| (1) Bearing | (4) O-ring, Gasket |
| (2) Shaft labyrinth | (5) Oil filter |
| (3) Impeller shim (1st level, 2nd level) | |

2. Motor

- | | |
|----------------|--------------------------------------|
| (1) Bearing | (3) O-ring, Gasket |
| (2) Rear cover | (4) Filter Drier, Moisture Indicator |

- Excluded Work from standard

1. Starter panel Disassemble Inspection(repairing)
2. Replacing Motor Coil
3. Cleaning the Heat exchanger

- The Others

1. Compressor

- | | |
|----------------------------|--------------------------------|
| (1) Impeller | (6) Gear |
| (2) Diffuser | (7) Plate type Heat exchanger |
| (3) Impeller cover | (8) Capacity adjustment device |
| (4) Impeller shaft | (9) Lock nut, bolt |
| (5) Return channel 1, 2, 3 | |

2. Motor

7-2. Periodic maintenance

Daily inspection

Checks the evaporator and condenser pressure, oil tank pressure, differential oil pressure and discharge oil pressure of the chiller. Compare the values with the ones of the general chillers maintenance table.

- Compressor and motor daily inspection standard

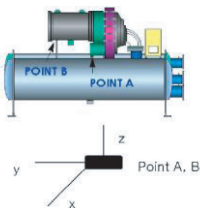
Classification	Inspection items	Inspection method	Criteria
Compressor, Motor	Motor Cooling Condition	Check the refrigerant flow via. Moisture Indicator	Able to see the refrigerant flow
	Able to see the refrigerant flow	Measure the temperature of the outer surface of the motor using a surface thermometer	Able to see the refrigerant flow
	Motor Drain Temp.	Measure the draining pipe's outer surface with the thermometer	Able to see the refrigerant flow
	Motor Drain Oil Flow	Measure using Differential Pressure	Able to see the refrigerant flow
	Compressor discharge gas temp.	Check temp. at the control panel	Able to see the refrigerant flow
	Vibration/noise		Check with the hand and Ear Measure using the vibration measuring instrument if necessary Noise: Below 85dB When there's no abnormal vibration below x,y,z: 25 m

* The motor adopts liquid refrigerant cooling system. It supplies the liquid refrigerant by the differential pressure between the condensing and evaporation pressure.

* Check and make sure that the refrigerant liquid supplying line's moisture indicator is showing green. If the green color is altered to yellow, it means that the moisture quantity has exceeded more than the standard quantity in the machine. Thus, replace the filter dryer.

Figure 87. Compressor and motor daily inspection standard

- Daily inspection of Condensers

Classification	Inspection items		Inspection method	Criteria
Condenser	Cooling water	Inlet	Check at the Panel	Below 34 °C
		Outlet	Check at the Panel	21°C or more
	Condensing pressure state		Check at the Panel	5~10 kg/cm ²
	Heat exchanging state		Temperature difference between condensing temp. and cooling water outlet temp.	Temperature difference between condensing temp. and cooling water outlet temp.

* If the outlet temperature of the cooling water is below 21°C, condensing pressure would be decreased, which will lead to a lack of differential pressure at the motor cooling and the oil cooler and finally become the situation of insufficient of cooling water.

The main cause of worsening the heat exchange can be seen for the scale attached inside cooling pipe and insufficient cooling water amount.

Figure 88. Condenser daily inspection standard

- Evaporator daily inspection standards

Classification	Inspection items		Inspection method	Criteria
Evaporator	Chilled water	Inlet	Check at the Panel	Below 5~15°C
		Outlet	Check at the Panel	Above 3°C
	Above 3°C		Check at the Panel	5~10 kg/cm ²
	Heat exchanger condition		Temperature Difference between the evaporation temp. and the chilled water outlet temp.	0.5~3°C
	Refrigerant charging amount		Check through the sight glass	
	Refrigerant condition		Check through the sight glass	

When evaporation pressure is decreased, the evaporator tube freezes and eventually damaged, or compressor surge would also be possible. Causes of the decreased evaporating pressure would be insufficient refrigerant quantity, low temperature water and abnormal heat exchanging efficiency. Like the condenser tubes, if foreign substances are in or the scales adhered, corrosion may occur which will lead to a in efficient heat exchanging. This happens to decrease the refrigeration ability or may be the cause for surge.

Figure 89. Evaporator daily inspection standard

- Daily inspection standard of Compressor and motor. Generally, the failure ratio of a machine is distributed as the shape drawn in the following Fig.

Classification	Inspection items	Inspection method	Criteria
Oil	Oil amount	Visual inspection	At least one of two sight glasses should have oil level appearance.
	Temp.	Check at the Panel	30~60°C
	Differential Pressure	Check at the Panel	0.8 kg/cm ²
	Oil Pressure Vibration	Check at the Panel	No Vibration
	Leakage	Visual inspection of the oil system	There shall be no leak
	Oil pump Noise	Check by ear	No abnormality
	Oil pump remaining flow operation	Stop the chiller and check with watch	300 sec.

Figure 90. Compressor and motor machine failure ratio

<Lubrication cycle>

The oil is taken through the manual valve into the tank. The level of the oil can be detected by the one sight glasses on the oil tank. When the compressor is stopped oil should be able to be found through the sight glass.

The temperature of the oil tank is displayed on the panel and while operation, the temperature would be 30~65 °C.

The oil pump transfers the oil from the tank and the pressure at that time would be above 0.8kg/cm².

The oil pump is sending the oil to the oil filter, where a valve is installed so that there is no need to drain the whole system when replacing the filter.

Afterwards the oil is sent to the oil cooler and then cooled by the refrigerant from the condenser.

The refrigerant cools off the oil as low as 30~60°C.

Oil that left the cooler passes through the oil pressure transducer and then to the refrigerant expanding valve's temperature sensor box, flows to the bearings and gears for lubrication.

The oil temperature is measured at the high-speed thrust bearing and the oil is drained to the oil tank that is located at the lower part of the compressor.

The control device operates the oil to the oil pump prior to the main operation for 120~180 seconds at a constant pressure. At stoppage when the main operation has stopped, it performs a 300 seconds of after lubrication.

Soft start-up opens guide vane slowly during the start-up to prevent foaming of the oil.

If the guide vane opens too quickly, it will let the refrigerant in the oil to be boiled because of the intake pressure's rapid decrease, which will eventually cause foaming. This foaming will lead to dropping the pressure in oil pump, and the low pressure of oil lead finally bad lubrication.

Monthly inspection

- Compressor and motor monthly inspection standard

Classification	Inspection category	Inspection method	Criteria
Compressor and Motor	Motor insulation	Measure at 1000V mega	Above 100 MΩ
	Vane operation	Visual inspection of the opening status	In Vane Full Close, 0% Check indication in Vane Full Open, 100%
		Check the status of opening indication	Soft movement of Indication Value
	Protector insulation	500V mega (Protector ~ Main Coil, Protector ~ ground) Measuring	Above 3 MΩ
	Characteristics of start-up	Mark ● for the corresponding start-up method 1. Direct standing start-up 2. Y-Δ start-up 3. Kondorfer start-up 4. Reactor start-up * In case of chilled water outlet temp _°C	Time of start-up current flow t: 5~25 sec.
Start-up current: A			
Timer set value (sec.)			

Figure 91. Compressor and motor monthly inspection standard

- Generally the starting current of the motor is about 600% that of the rated current in direct input. And in case of y-Δ, it is 200%, for kondorfer 250%, and for Reactor 400%.
- Measuring frequency and record should be at least once a month for daily/monthly inspections. This data can be the clue of solution if problems are occurred to the motor.

- Lubrication system monthly inspection standard

Classification	Inspection items	Inspection method	Criteria
Oil	Oil charging amount	Check through the sight glass	Refer to the standard charging amount
	Oil pump motor insulation	Check through the sight glass	3MΩ

Figure 92. Lubrication system monthly inspection standard

Yearly inspection

- Yearly inspection

Classification	Inspection items	Inspection method	Criteria
Motor	Motor Terminal fasten bolt	Check the slackness	Check the loose
			Loose terminal finishing state
Condenser	Chemical analysis	Water quality analysis	Water quality standard
	Tubes condition	Check it at the operation record or by opening the waterbox.	No pollution
Evaporator	Chemical analysis	Water quality analysis	Water quality standard
	Tubes condition	Check it at the operation record or by opening the waterbox.	No pollution
Oil and lubricant	Oil cooler cleaning	Clean by refrigerant	No corrosion or pollution should be present
	Ejector cleaning	Disassemble cleaning	No abnormality
	Filter cleaning	Filter exchanging, Cleaning the housing	No abnormality
	Oil tank cleaning	Disassemble cleaning	No pollution
	Oil Replacing		2000 hours or 1 year

Figure 93. Yearly inspection standard

<Water quality analysis>

The cooling water at the open circulation type cooling tower uses the evaporation latent heat to lower down the water temperature and also recycles it.

At this time the water evaporates and the chloride ions in the water and the acid ions will increase. This will lead to enrichment situation and eventually deteriorate the water quality.

Also, in the cooling tower, water and air are always in contact with each other and the contaminating material (automobile exhaust gas, sulfurous acid gas, dust, gas of chemical plants such as ammonia or petroleum gas, etc.) deteriorates the water quality even more.

These pollutant causes can corrode the pipe, scales adhered causes the tubes to have holes and lockouts which are leading to a decreasing effect of heat exchanger.

Therefore, it may end to replacing the tubes, increased power cost, or the chiller failure.

Thus, cooling water quality must be maintained at a certain level.

Water quality analysis should be taken place periodically and if the results are out of the standards boundary (Table 23.), it must be replaced. At the beginning of the season and at the initial starting of the machine, water quality analysis is inevitable.

To prevent the cooling water enrichment, certain amount of cooling water should be drained during the circulation and then supplying fresh cooling water. Another way of water quality analysis would be using chemical handling.

<Tubes State>

If water corroded dirt is adhered or foreign substances are mixed in the tubes, resistance is increased which makes it hard for the chiller to have a good efficiency. It also makes it easy to cause surge.

If sandy like solid materials are mixed in the cooling water, erosion or corrosion may occur at the entrance of the tubes, therefore when cleaning the tubes make sure that you check the inner surface of it.

Install a filter at the inlet of the cooling water pipe. Generally, a cooling tower is used for the cooling water system, but when using the subterranean water or the riparian water it is possible for the scales to be adhered easily due to low quality of water compared to the chilled water.

	Item	Cooling water system			Chilled water system		Trend	
		Circulation type		Once through type	Circulating water (Below 20°C)	Supplied water	Corrosion	Scaling
		Circulating water	Supplied water	Once through water				
Standard item	pH(25°C)	6.5~8.2	6.0~8.0	6.8~8.0	6.8~8.0	6.8~8.0	○	○
	Electric conductivity (Ma/m)(25°C) (μs/cm) (25°C)	below 80 below 800	below 30 below 300	below 40 below 400	below 40 below 400	below 30 below 300	○	○
	Chloride ion (mgCl ⁻ /L)	below 200	below 50	below 50	below 50	below 50	○	
	Sulfuric ion (mgSO ₄ ²⁻ /L)	below 200	below 50	below 50	below 50	below 50	○	
	Acid consumption (pH4.8) (mgCaCO ₃ /L)	below 100	below 50	below 50	below 50	below 50		○
	Total hardness (mgCaCO ₃ /L)	below 200	below 70	below 70	below 70	below 70		○
	Calcium hardness (mgCaCO ₃ /L)	below 150	below 50	below 50	below 50	below 50		○
	Ion silica (mgSiO ₂ /L)	below 50	below 30	below 30	below 30	below 30		○
Reference item	Iron (mgFe/L)	below 1.0	below 0.3	below 1.0	below 1.0	below 0.3	○	
	Copper (mgCu/L)	below 0.3	below 0.1	below 1.0	below 1.0	below 0.1	○	○
	Sulfide ion (mgSO ₄ ²⁻ /L)	Not detected	Not detected	Not detected	Not detected	Not detected	○	
	Ammonium ion (mgNH ₄ ⁺ /L)	below 1.0	below 0.1	below 1.0	below 1.0	below 0.1	○	
	Residual chlorine (mgCl/L)	below 0.3	below 0.3	below 0.3	below 0.3	below 0.3	○	
	Free carbon dioxide (mgCO ₂ /L)	below 4.0	below 4.0	below 4.0	below 4.0	below 4.0	○	
	Stability index	5.0~7.0	—	—	—	—	○	○

Note)

- (1) Name and unit of the items are based on KS MD100.
- (2) O sign within the table refers to the factor related to the corrosion or scaling trend.
- (3) Unit and value within the parenthesis show data based on the previous unit, for reference.
- (4) If the temperature is high (40°C or above), generally the corrosion rate becomes high especially for steel that directly contacts water without any protective coating. It is recommended to have an effective plan for the water such as adding anti-corrosive additive or air removal process, etc.

Table 55. Water quality management standard for chilled water/cooling water

Refrigerant and oil charge amount
Single stage centrifugal chiller

Frame	Refrigeration capacity (RT)	Amount of refrigerant (kg)	Oil quantity (L)
3	250 ~ 400	450	40
4	500 ~ 600	550	40
5	650 ~ 850	750	60
6	900 ~ 1300	950	62
7	1400 ~ 2000	2100	120

Table 56. Refrigerant and oil charging amount for Single Stage centrifugal chiller

7-3. Maintenance during off-season

- (1) If the operation needs to be stopped, to reduce the machine pressure and leak possibility, move the refrigerant to a separate refrigerant container.
- (2) To prevent intake of air into the machine, store the machine with about 5kg refrigerant charged or to apply 0.5kg nitrogen.
- (3) If the place where the machine is installed goes below 0°C frequently, to prevent the freezing, drain the cooling water, chilled water and condensed water. Also open the waterbox drain.
- (4) Leave the oil charged in the machine, and to maintain the minimum oil tank temperature, supply power to the oil heater.

7-4. Annual maintenance(1/2)

Inspection items		Inspection method	Criteria	Actual measurement	Decision																							
Compressor	○ Motor cooling status	Check refrigerant flow status from moisture indicator	Check flow status	Yes No																								
		Touch the surface of the motor with hand	10~30 °C	Pass Fail																								
	○ Motor insulation	Measured at 1000V	100MΩ or more	MΩ																								
	○ Start-up characteristics (mark O in the corresponding start-up method)	<p>In case of chilled water outlet temp. () °C</p>	Start-up time T=5~25 sec.	t = sec.	T1: start-up timer T2: subsidiary timer																							
			Start-up current: A	A= A																								
			Timer set value (sec.)																									
			<table border="1"> <thead> <tr> <th>Timer</th> <th>Y-Δ</th> <th>Kondorfer</th> <th>reactor</th> <th>Actual measurement</th> </tr> </thead> <tbody> <tr> <td rowspan="2">High pressure</td> <td>T1</td> <td>10/0.5</td> <td>10</td> <td>10/0.5</td> </tr> <tr> <td>T2</td> <td>20</td> <td>20</td> <td>20</td> </tr> <tr> <td rowspan="2">Low pressure</td> <td>T1</td> <td>15/0.5</td> <td>15</td> <td>15/0.5</td> </tr> <tr> <td>T2</td> <td>30</td> <td>20</td> <td>30</td> </tr> </tbody> </table>	Timer		Y-Δ	Kondorfer	reactor	Actual measurement	High pressure	T1	10/0.5	10	10/0.5	T2	20	20	20	Low pressure	T1	15/0.5	15	15/0.5	T2	30	20	30	
			Timer	Y-Δ		Kondorfer	reactor	Actual measurement																				
	High pressure	T1	10/0.5	10	10/0.5																							
		T2	20	20	20																							
Low pressure	T1	15/0.5	15	15/0.5																								
	T2	30	20	30																								
Check timer set value with independent timer operation test after disconnecting high voltage.																												
○ Vane operation	Check opening 0~100%	Check 0, 100%	Pass Fail																									
	Check opening status	Shall operate smoothly	Pass Fail																									
○ Vane opening	Check opening ratio	In normal operation	%																									
○ Operation current	Check current value	Less than 105% of the rated	A																									
○ Motor stopped time	After chiller is stopped, check from half-load side of the motor when the meter axes stopped time	10~60 sec.	sec.																									
○ Discharge gas temp.	Measure the surface of the bolts with thermometer	About 30~90°C	°C																									
○ Vibration noise	Touch with hand or check with ears	When there is no problem	Pass Fail																									
			<table border="0"> <tr> <td>Xa</td> <td>= μ</td> </tr> <tr> <td>Ya</td> <td>= μ</td> </tr> <tr> <td>Za</td> <td>= μ</td> </tr> <tr> <td>Xb</td> <td>= μ</td> </tr> <tr> <td>Yb</td> <td>= μ</td> </tr> <tr> <td>Zb</td> <td>= μ</td> </tr> </table>	Xa	= μ	Ya	= μ	Za	= μ	Xb	= μ	Yb	= μ	Zb	= μ													
Xa	= μ																											
Ya	= μ																											
Za	= μ																											
Xb	= μ																											
Yb	= μ																											
Zb	= μ																											

7-4. Table for Annual maintenance(2/2)

Inspection items			Inspection method	Criteria	Actual measurement	Decision (OX)
Condenser	○ Cooling water	Inlet	Check with thermometer	34°C or less (standard condition)	°C	
		Outlet	Check with thermometer	24°C or more (standard condition)	°C	
	○ Condensing pressure (temp.)	Check with manometer (thermometer)	6~10 kg/cm ² (26~42 °C)	kg/cm ² (°C)		
	○ Heat exchanging status	Difference between condensing temp. and cooling water outlet temp.	1~3 °C	°C		
Evaporator	○ Chilled water	Inlet	Check with thermometer	6~15 °C		
		Outlet	Check with thermometer	4°C or more		
	○ Evaporating pressure (temp.)	Check with manometer (thermometer)	2~5 kg/cm ² (0~21 °C)	kg/cm ² (°C)		
	○ Heat exchanging status	Difference between chilled water outlet temp. and evaporating temp.	1~3 °C	°C		
	○ Refrigerant charging amount	Check through sight glass	Refer to 10.5 standard charging amount			
	○ Boiling status	Visual inspection		Yes No		
Lubrication system	○ Refrigerant contamination	Check through sight glass	Whether contaminating material, moisture, oil is included	Pass Fail		
	○ Oil amount	Visual inspection	Check with sight glass on the gear box during operation	Pass Fail		
	○ Oil charging amount	Accumulated charging amount after charging new refrigerant	Refer to 10.5 standard charging amount	Month Day /		
	○ Oil tank temp.	Check with thermometer	30~65 °C	°C		
	○ Temp. of Bearing	Check with thermometer	50~85 °C	°C		
	○ Oil differential pressure	Check with manometer	Oil supply pressure – Oil tank pressure (0.8 kg/cm ² or more)			
	○ Oil pressure vibration	Vibration of the pressure value		Yes No		
	○ Oil leakage	Oil system visual inspection		Pass Fail		
	○ Oil pump noise	Check with ears		Pass Fail		
○ Oil pump remaining operation	Measure with watch	300 sec.	min.			
Safety Device	Vane operation	Manual opening of vane	• Stop at rated current • Closed at 105%	Pass Fail		
	Chilled water differential pressure switch	Decrease chilled water amount to check the operation		Pass Fail		
	Cooling water differential pressure switch	Decrease cooling water amount to check the operation		Pass Fail		

Table 57. Table for Annual maintenance

7-4. Table for Annual maintenance

Operation Inspection Table (A)

Inspection date: Year Month Day

Address	(Tel)		
Company	(Staff in charge)		
Model		Serial No.	
Main motor	Serial No.	Rated voltage(V):	
	Max. output(KW):	Rated current(A):	
<u>Changes</u>			
<u>Replaced parts</u>			
<u>Conclusion</u>			

Person in charge of service:

Note:

1. The manufacturer is not responsible for the problems happened due to the reasons as follows; poor water quality, customer's poor maintenance and natural disaster.
2. Overhaul for the compressor should be done in 5 years or in 10000 hours, whichever comes first.
3. Beware that some items can be changed without prior notice for the product improvement.

Table 58. Operation Inspection table

7-5. Oil maintenance

Compressor oil replacement

- Checking the Lubrication System

Record the level of the oil on the oil tank sight glass in operation, and check the level when the chiller is stopped. If the level has dropped below the lower part sight glass, it is necessary to check whether the oil recovery system is working properly. If oil is needed, add it through the oil charging valve. To charge the oil opposite from the refrigerant pressure, a pump is needed. The charging quantity of the oil should be referred to LG Electronics and the specification of the additional oil should match with that of LG Electronic's chiller oil. Added oil shall be recorded for its amount and date.

- Oil specification

Use oil recommended by LG.

Category	Unit	Characteristic value	Meaning
Density	kg/m ³	960	Check for the specified product and for any foreign substance mixed
Color	°C °C	L0.5	Check initially specified product
Ignition point	mm ³ /s	250	Fire and explosion risk, preservation stability
Flowing point	mgKOH/g	- 40	Stability during the initial start-up, preservation stability
Kinematic viscosity @ 40 °C		67.3	Lubrication, friction loss, sealing effect, cooling capability
@ 100 °C		8.29	
Viscosity index		90	Relationship to the viscosity change due to temp. change
Total acid value		0.01	Measure oxidation of the oil itself compared to the initial total acid value
Corrosion of the copper plate		1	Anti-corrosion ability of the oil
(100 °C, 3h)			

Table 59. Oil specification

<Available oils>

- Oil from LG
- Japan sun oil : Icecold SW68
- Castrol : Castrol Icematic SW68

• Oil replacement

We recommend you to replace the oil on the first year of the chiller's operation and every 3-year period depending on the oil analysis.

- 1) Mark the current oil level.
- 2) Open the control circuit breaker and oil heater circuit breaker.
- 3) Gradually open the oil charging valve to drain the oil. Opposite from the chiller pressure, open the valve very slowly.
- 4) After locking the valves at both ends of the oil filter, use the valve to gradually reduce the pressure within the oil filter, and change the oil filter.
- 5) Charge oil to the machine using a pump.
To be charged till the level of middle or higher at the sight glass, approximately 50~60ℓ of oil is needed. Heat until the oil temperature reaches 40°C by turning on the oil heater. For the sake of controlling test, operate the oil pump manually for 2 minutes. The level of the oil should be indicating at the sight glass.

Oil Filter Change**- Oil Filter Change**

Replace the oil filter annually or in the time of overhaul.

Oil filter can be replaced in a condition that the refrigerant is in the chiller.

- 1) Check if the compressor is in the stop state and also if the compressor circuit breaker is opened.
- 2) Shut down the oil pump power.
- 3) Close the oil filter separator valves.
- 4) When opening the oil filter housing, do it slowly.

**CAUTION**

Decrease the pressure of the oil filter housing very slowly because it is in a high temperature state.

- 5) Make vacuum in the filter housing after the filter exchange or assembling. After the vacuum has been done, open the separation valve and if there is insufficient amount of oil, add oil through the charging valve.

7-6. General Maintenance

Non-periodical maintenance

- Maintenance of the compressor bearing and the gear
The core of maintaining bearing and the gear can be said adequate lubrication. Preserve the recommended oil amount, temperature and pressure by using the right level of oil. Do a thorough maintenance check-up on the lubrication system periodically. To inspect the bearing, the compressor must be completely disassembled. To take out the bearing and to inspect it, a high technology specialist is needed. Excessive abrasion can occasionally be detected by excessive vibration or by the bearing's temperature.
- Refrigerant leak inspection
HFC-134a has higher pressure than air in room temperature, so it requires the refrigerant leak test utilizing electronic detector, halogen leak detector or soapy water.
If the refrigerant leak is overall the entire chiller with large volume, immediately stop using the system and fix it first. If the refrigerant was lost or the machine has been opened during the service period, the chiller itself or related tank must be taken leak test by adding pressure.
Refer to 5-5-2 for leak inspection.

Charging refrigerant and leakage test

- Refrigerant characteristics
Usage refrigerant is HFC-134a.
HFC-134a evaporates at -26°C in normal air pressure, so it shall be stored in a pressured container or storage tank. Refrigerant has almost no smell when it is mixed with air, and it is non-combustible in air pressure.



CAUTION

The refrigerant HFC-134a dissolves oil and some non-metallic material, dries skin, and makes oxygen deficiency resulting in suffocation at high concentration. Thus be very careful not to inhale or touch by hand or eye contact when you handle the refrigerant.

<Characteristics Table>

Molecule formula		CH ₂ F-CF ₃
Molecule amount		102.031
Boiling point (air pressure)	°C	- 26
Freezing point	°C	- 101
Critical temp.	°C	101
Critical pressure	kg/cm ² .A	41.5
Density of saturated fluid (25°C)	kg/m ³	1206
Specific volume of saturated vapor (25°C)	m ³ /kg	0.031
Specific heat ratio, vapor (25 °C, air pressure)		1.1186
Evaporative latent heat (25°C)	kcal/kg	42.54

Table 60. The property of HFC-134a

- The adjustment of refrigerant charging amount

If it is necessary to control the refrigerant charging amount for a better performance of the machine itself, operate the machine in a design load and add or remove the refrigerant until it satisfies the difference temperature of the chilled water outlet and the evaporator refrigerant.

Do not over charge. Refrigerant can be charged through the storage tank or directly charged into the chiller.

- Refrigerant leak inspection

HFC-134a has higher pressure than air in room temperature, so it requires the refrigerant leak test utilizing electronic detector, halogen leak detector or soapy water. Check for a good room ventilation and check whether the leaked refrigerant is concentrated in one place of the room to prevent a wrong measurement result.

Before performing any repair for leak, move all refrigerant from the leaked container.

- Refrigerant leakage

If there is large refrigerant leak, chiller performance degraded or operation impossible, it is recommended to stop the chiller and repair first.

- Refrigerant filter

Refrigerant filter /drier in the refrigerant cooling pipes of the motor needs to be replaced once a year. It may require more frequent replacement according to the status of the filter. To find the existence of moisture in the refrigerant, sight glass is installed next to the filter. If moisture through the sight glass is detected, perform a thorough leak inspection to find the source of the water.

Cleaning Heat exchanger tubes (Evaporator/Condenser)

Inspect Heat exchanger tubes

- Evaporator

When the first operation season is over, clean the evaporator tubes.

These tubes have foreign substances inside. Thus to clean the tubes thoroughly, a special caution should be exercised. The tubes condition, at this time, will become the data to determine how often tubes needs to be cleaned and whether the water treatment in the chilled water(brine) system is appropriate. Check for any corrosion or scale in the chilled water inlet/outlet temperature sensor. For corrosion, replace the sensor, and for scale, remove the scale.

- Condenser

Cooling water circuit is generally an open type system, so it is easy to have the tubes contaminated and scale to be adhered. Therefore, the tubes in condenser need to be cleaned at least once a year. If the water quality is contaminated, clean more frequently. Check the corrosion or scale in the cooling water inlet/outlet temperature sensor. For corrosion, replace the sensor, and For scale, remove the scale.

The reason that it is higher than the normal condenser pressure and not reaching previous chilling load is generally because tubes are contaminated or there is an air in the machine.

If the temperature difference between cooling water outlet and condenser refrigerant is great, the condenser tubes may be contaminated or water flow is not good.

HFC-134a is a high pressure refrigerant, so it is easier to have refrigerant leak than air enters inside.

During the cleaning of the tube, use a specially designed brush to prevent scratch on the tubes wall.

Never use wire brush.

Check items before operation after long term stop**- Check list before start-up****1. Control Panel and Electric lines**

Shut down the breaker, check for any foreign substance in the control parts, switches, etc.. Controls the switches to check whether it operates in normal and connection status for each connector are OK.

2. Voltage

Read the voltage meter on the starter panel and check if it matches with the usage voltage on the name plate of the chiller.

3. Chilled and cooling water circulation system

Operate cooling water and chilled water pumps to check if their operation status are properly displayed on the panel.

- Control device operation test**1. Check the connection condition**

Check if the power, sensor, etc. are properly connected.
Special checking should be taken to power line.

2. After power on, check the display status of the panel.

Pay special attention if there is any sign of short circuit for about 5 sec. after power on.
If any of the following symptoms occur, immediately disconnect power and check for problem.

3. Check values displayed on the panel

Check whether each sensor value displayed on the panel is correct.
If any error message is displayed or sensor value is not normal, check sensor connection status.

4. No power operation

Run while the main motor power is off, and check for normal operation to the operation signal of starter panel.
If any error message appears, check the corresponding part.

- Check safety devices**Flow operation test for chilled water and cooling water**

Close the valves installed on the cooling water and chilled water pipes to check whether the flow checking switch is working correctly.

**CAUTION**

For the prevention of severe scales and the removal of the scales, treat with chemical. For a proper treatment, consult with water treatment specialist.

8. TROUBLESHOOTING

8-1. Causes and actions for alarms

Actions for problems

- How to react to the problem display from controller
- Please take actions according to the following instructions

Check the displayed contents and refer to the help message. Select help menu corresponding to the problem message and check the contents of the problem and how to react. Remove the cause of the problem according to the parts or drawing of the circuit related to the problem or manual. If the contents for the problem is no in the manual or drawing, consult our experts. Check the temperature control status, pressure status, etc.

Troubleshooting (1/3)

Abnormal category	Displayed contents	Cause	Action
Chilled Water Inlet temperature Sensor	Chilled Water Inlet temperature Sensor Error	Sensor disconnected/short-circuit	Main board malfunction Check parts status or wiring Replace parts or re-wire`
Chilled water outlet temperature sensor	Chilled water outlet temperature sensor Error	Sensor disconnected/short-circuit	Main board malfunction Check parts status or wiring Replace parts or re-wire`
Cooling water inlet temperature Sensor	Chilled water outlet temperature sensor Error	Sensor disconnected/short-circuit	Main board malfunction Check parts status or wiring Replace parts or re-wire`
Cooling water outlet temperature Sensor	Chilled water outlet temperature sensor Error	Sensor disconnected/short-circuit	Main board malfunction Check parts status or wiring Replace parts or re-wire`
Compressor discharge temperature sensor	Compressor discharge temperature sensor error	Sensor disconnected/short-circuit	Main board malfunction Check parts status or wiring Replace parts or re-wire`
Bearing temperature sensor	Bearing temperature sensor problem	Sensor disconnected/short-circuit	Main board malfunction Check parts status or wiring Replace parts or re-wire`
Motor winding R phase temperature sensor	Motor winding R phase temperature sensor error	Sensor disconnected/short-circuit	Main board malfunction Check parts status or wiring Replace parts or re-wire`
Motor winding S phase sensor	Motor winding S phase sensor error	Sensor disconnected/short-circuit	Main board malfunction Check parts status or wiring Replace parts or re-wire`
Motor winding T phase sensor	Motor winding T phase sensor error	Sensor disconnected/short-circuit	Main board malfunction Check parts status or wiring Replace parts or re-wire`
Evaporator pressure sensor	Evaporator pressure sensor error	Sensor disconnected/short-circuit	Main board malfunction Check parts status or wiring Replace parts or re-wire`
Condenser pressure sensor	Condenser pressure sensor error	Sensor disconnected/short-circuit	Main board malfunction Check parts status or wiring Replace parts or re-wire`
Oil tank pressure temperature sensor	Oil tank pressure temperature sensor error	Sensor disconnected/short-circuit	Main board malfunction Check parts status or wiring Replace parts or re-wire`
Oil pump pressure sensor	Oil pump pressure sensor error	Sensor disconnected/short-circuit	Main board malfunction Check parts status or wiring Replace parts or re-wire`
Current transducer	Current sensor error	Sensor disconnected/short-circuit	Main board malfunction Check parts status or wiring Replace parts or re-wire`
Voltage transducer	Voltage sensor error	Sensor disconnected/short-circuit	Main board malfunction Check parts status or wiring Replace parts or re-wire`

Troubleshooting (2/3)

Abnormal category	Displayed contents	Cause	Action
Power transducer	Power sensor error	Sensor disconnected / short circuit	Main board malfunction Check parts status or wiring Replace parts or re-wire
Compressor discharge temperature	Compressor discharge temperature high	Compressor discharge temperature is detected to be over set value	Check compressor discharge temperature displayed on the controller screen. Check the set value and correct if it is wrong.
Oil tank temperature	Oil tank temperature high	Oil tank temperature is detected to be over set value	Check oil tank temperature displayed on the controller screen. Check the set value and correct if it is wrong.
Bearing temperature	Bearing temperature high	Bearing temperature is detected to be over set value	Check bearing temperature displayed on the controller screen. Check the set value and correct if it is wrong.
Motor winding R(S,T) phase temperature	Motor winding R(S,T) phase temperature high	Motor winding R(S,T) phase temperature is detected to be over set value.	Check motor coil R(S,T) phase temperature displayed on the controller screen. Check the set value and correct if it is wrong.
Condenser pressure	Condenser pressure high	Condenser pressure is detected to be over set value	Check condenser pressure displayed on the controller screen. Check the set value and correct if it is wrong
Motor Winding high temp. contact	Motor Winding high temp. active	Motor winding high temp. contact is active	Check motor winding temp. Check winding high temp. contact status and wiring status
Chilled water outlet temp	Chilled water temp low Error	Chilled water outlet temp. is detected to be below set value. There is no or small cooling load	Check chilled water outlet temp. or temp. on the thermometer. Check the set value and correct if it is wrong
Evaporator pressure	Evaporator pressure low	Evaporator pressure is detected to be below set value.	Check evaporator pressure displayed on the controller screen. Check the set value and correct if it is wrong
Oil differential pressure	Oil differential pressure low	Oil differential pressure is detected to be below set value.	Check oil differential pressure displayed on the controller screen. Check the set value and correct if it is wrong
Main power voltage	Main power voltage problem	Main power voltage is detected to be below set value.	Check the voltage of main power and the voltage set value. Check the status of the related parts and wiring Replace parts or repair
Starter panel abnormal	Starter panel abnormal	Starter panel abnormal, contact is active	Check the contact status of the starter panel and remove the cause of the contact. Check related parts status or wiring Replace parts of malfunction or re-wire
Start-up failed	Start-up failed	During the start-up 2M magnet switch is not working	Check 2M magnet operating status. Check the status of the parts or wiring Replace parts or re-wire
Chilled water pump Interlock	Chilled water pump Interlock Error	Pump interlock signal is disconnected during normal operation. Pump stopped Wrong wiring IO board malfunction	Check parts status or wiring Replace parts or re-wire
Cooling water pump Interlock	Cooling water pump Interlock Error	Pump interlock signal is disconnected during normal operation. Pump stopped. Wrong wiring IO board malfunction	Check parts status or wiring Replace parts or re-wire

Troubleshooting (3/3)

Abnormal category	Displayed contents	Cause	Action
Vane closed switch	Vane is not closed	Start Vane Close Switch is open	Check vane closed switch operation status and wiring. Adjust position of vane closed switch or re-wire
Condenser high pressure	Condenser high pressure contact active	Condenser pressure is higher than the pressure switch set status	Check condenser pressure. Check condenser high pressure contact status or wiring Replace parts or re-wire
Evaporator refrigerant low temp.	Evaporator Refrigerant Low Temp Contact Activate	Evaporator refrigerant temp. is lower than the switch set status	Check evaporator refrigerant temp. Check evaporator refrigerant low temp. contact status or wiring Replace parts or re-wire
Surge occurred	Surge occurred	Surge occurred	Check surge current change amount Reset the surge protection area
Oil pump	Oil pump overload contact active	Oil pump current is more than overload set current	Check oil pump overload setting status and wiring Replace parts or re-wire
Chilled water flow interlock	Chilled water flow low abnormal	Flow signal is disconnected during normal operation. Pump stopped Flow (differential pressure) switch setting problem. Wrong wiring. IO board malfunction	Correct set value and check Check parts status or wiring. Replace parts or re-wire
Cooling water flow interlock	Cooling water flow low abnormal	Pump interlock signal is disconnected during normal operation. Pump stopped Wrong wiring. IO board malfunction	Check parts status or wiring. Replace parts or re-wire
Start-up competed signal (2M)	Delta contactor open during operation	Delta contactor signal is disconnected during operation	Check parts status or wiring. Replace parts or re-wire
Evaporator refrigerant temp.	Evaporator refrigerant temp. low temp. problem	Evaporator refrigerant temp. is detected to be lower than set value	Check evaporator refrigerant temp. displayed on the controller screen. Check the set value and correct if it is wrong.
Communication	MAIN <-> I/O communication error	Communication error between boards	Check parts status or wiring. Replace parts or re-wire
Sensor correction	Set value is damaged. Sensor needs to be set	Sensor is not corrected	Calibration using precision resistance device
Main board	Main board reset	Main board is reset during operation	Check voltage applied to the controller and wiring. Remove cause of noise.
Display device	Display board reset	Display board is reset during operation	Check voltage applied to the controller Remove cause of noise. Check wiring

Table 61. Troubleshooting

Remedy for abnormal status

Vane sensor error

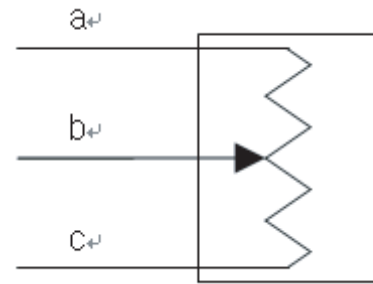

Figure 94. Vane sensor

Vane sensor

Release vane sensor connection from the relay board. After converting the tester to the resistance measurement mode, measure resistance between a and b, and there shall be a certain resistance. And after converting the vane to manual operation, when the vane is moved, there shall be vane sensor movement and change in resistance value. Even if the vane sensor is moving but there is no change of resistance value, wiring is wrong or vane sensor is damaged. While vane is completely closed, and opened completely, if the resistance between a and b increases uniformly and resistance between b and c of the vane sensor decreases uniformly, vane sensor is OK. Also measure resistance between a, b, c, and main body, and it shall not be angle line.

If the vane sensor is normal, re-connect the sensor, completely close the vane, and check if vane value is 0% and 100% after completely opening. If the value changes and vane opening % is wrong, sensor needs to be set again.

If there is no change of value, check if 100% is set in 'sensor setting-guide vane setting' category, and check if A/D value sensor value changes when vane moves. If sensor value changes, set vane again.

If sensor value does not change, convert tester to DC voltage 30V measuring position, and when voltage is measured with + at the point where vane sensor "a" is connected and - at the point where vane sensor c is connected, DC 5V must be measured.

If the voltage is not correct, check relay board main input power.

If relay main power is normal, vane sensor is normal, and sensor value does not change, then replace relay board.

Temp. sensor(PT-100) problem

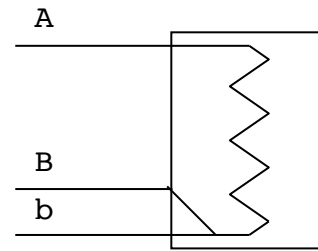

Figure 95. Temp. sensor

Release the temperature sensor connection from the controller and after converting the tester to resistance measurement mode, and when resistance between A and B, b is measured, the resistance shall be between 84.27Ω (-40°C) and 153.58Ω (140°C). (If you check from PT-100 temperature table, you can find the value corresponding to the actual temperature) If the resistance value is outside the measurement boundary, connection is wrong or sensor is damaged. Connect resistance generator(Decade resistance box) to the controller and as changing to 0°C at 100.00Ω , 10°C at 103.90Ω , and 28°C at 110.9Ω , check if the temperature displayed on the controller changes according to the change of the resistance. If normal value is not displayed on the screen, check if the sensor is set correctly.

If the sensor value does not change when the resistance value is changed, check the main power of the main board again, and if power is normal and there is no sensor input value, Master or slave board needs to be replaced.

Temp($^{\circ}\text{C}$)	Rt (Ω)	Temp($^{\circ}\text{C}$)	Rt (Ω)	Temp($^{\circ}\text{C}$)	Rt (Ω)	Temp($^{\circ}\text{C}$)	Rt (Ω)
-200	18.52	20	107.79	240	90.47	450	264.18
-190	22.83	30	111.67	250	194.1	460	267.56
-180	27.1	40	115.54	260	197.71	470	270.93
-170	31.34	50	119.4	270	201.31	480	274.29
-160	35.54	60	123.24	280	204.9	490	277.64
-150	39.72	70	127.08	290	208.48	500	280.98
-140	43.88	80	130.9	300	212.05	510	284.3
-130	48	90	134.71	310	215.61	520	287.62
-120	52.11	100	138.51	320	219.15	530	290.92
-110	56.19	110	142.29	330	222.68	540	294.21
-100	60.26	120	146.07	340	226.21	550	297.49
-90	64.3	130	149.83	350	229.72	560	300.75
-80	68.33	140	153.58	360	233.21	570	304.01
-70	72.33	150	157.33	370	236.7	580	307.25
-60	76.33	160	161.05	380	240.18	590	310.49
-50	80.31	170	164.77	390	243.64	600	313.71
-40	84.27	180	168.48	400	247.09	610	316.92
-30	88.22	190	172.17	410	250.53	620	320.12
-20	92.16	200	175.86	420	253.96	630	323.3
-10	96.09	210	179.53	430	257.38	640	326.48
0	100	220	183.19	440	260.78	650	329.64
10	103.9	230	186.84				

Table 62. PT-100 Temp. Table

4mA~20mA, 2-line type sensor, controller power used.

Check if the wiring between sensor and controller is properly connected.

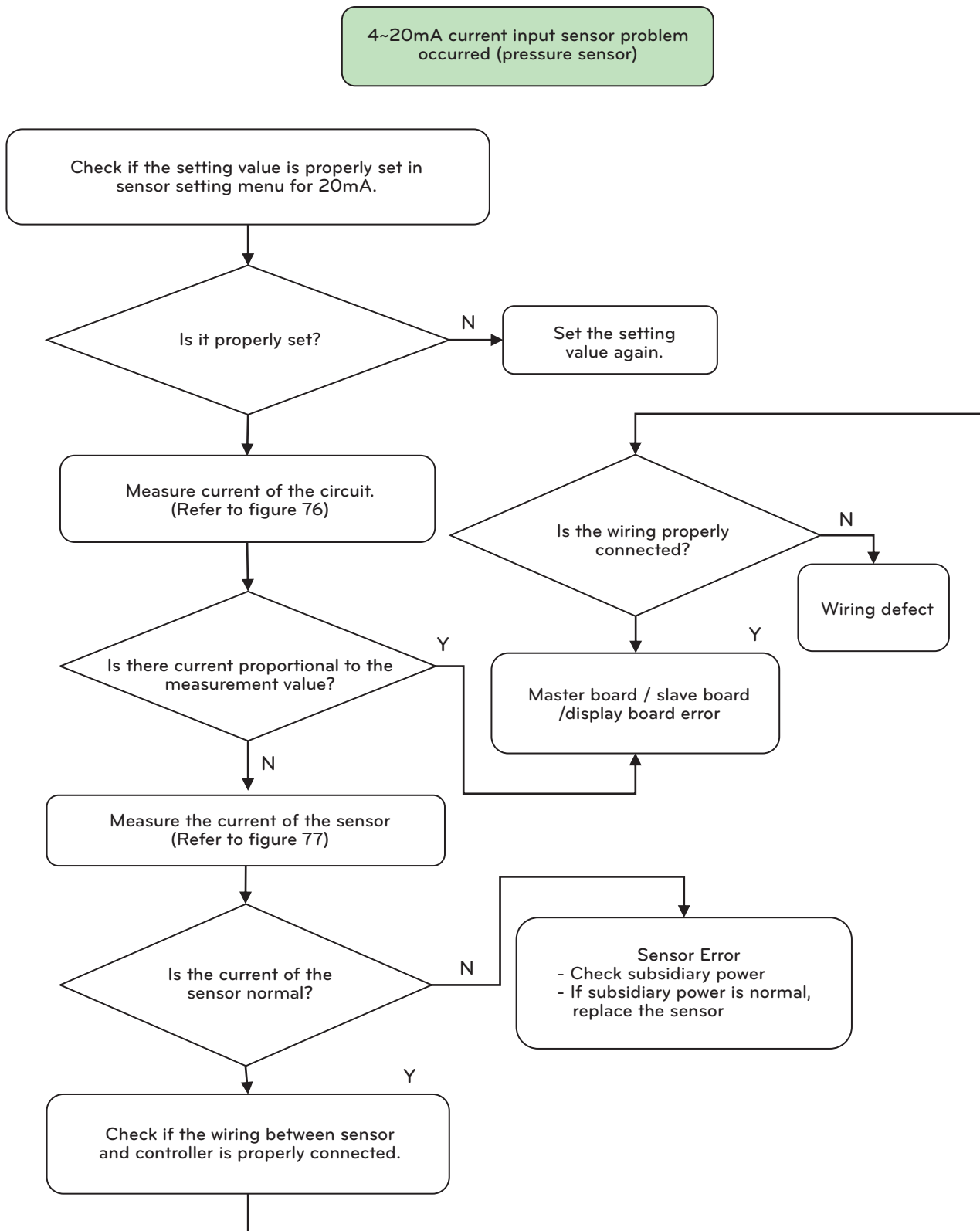

Figure 96. Pressure sensor

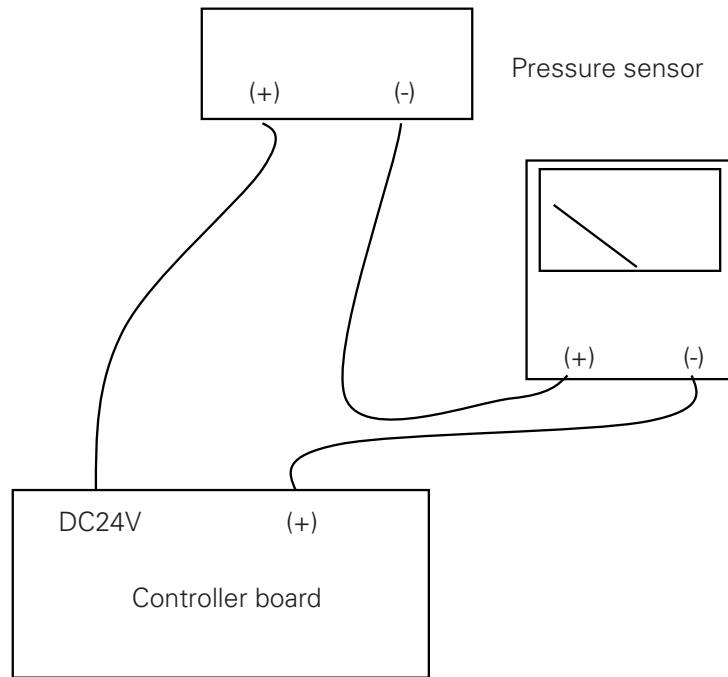

Figure 97. Current loop measurement circuit

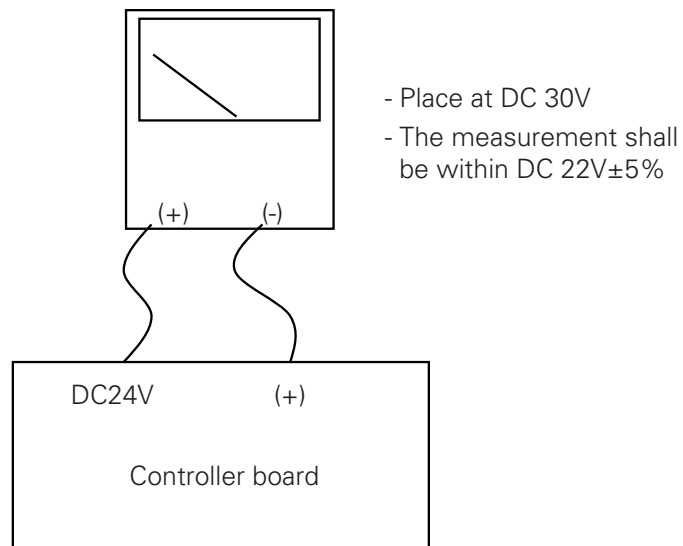

Figure 98. Controller voltage measurement circuit

Even if the inspection was carried out as above, if the cause couldn't be found, connect current generator to the input connector(DC24V and (+)) of the controller and check if the indicator value changes according to the change of the current.

In such case, if the controller indicator value does not change according to the change of the current, it shall be decided as controller defect.

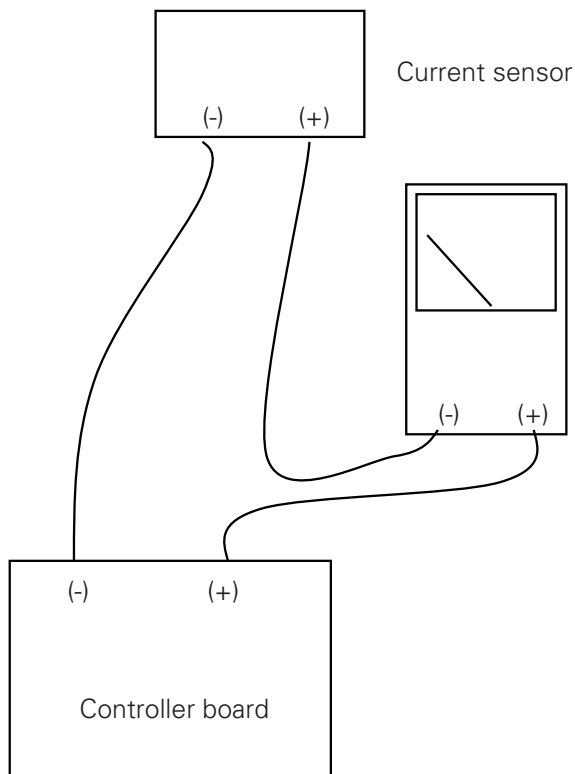

Figure 99. Pressure sensor

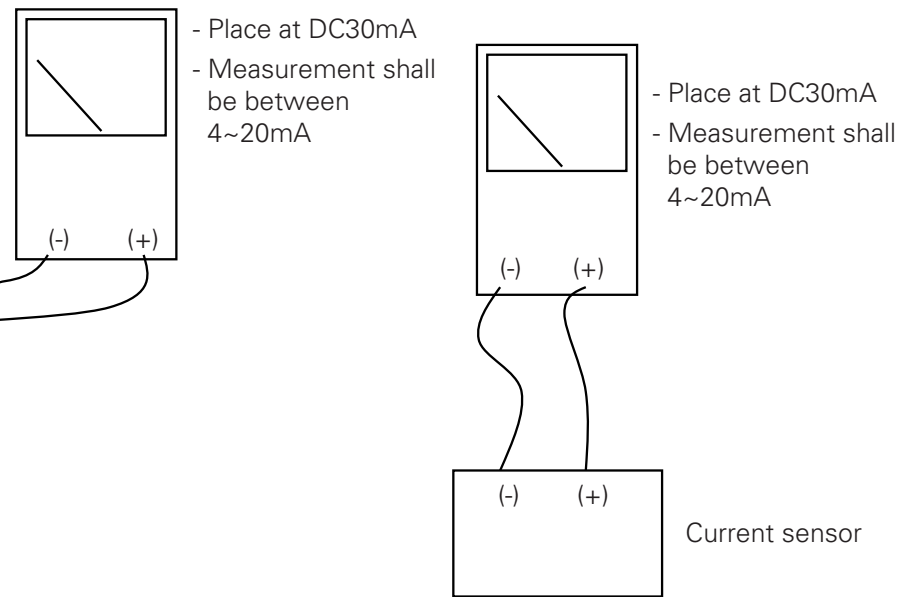

Figure 100. Current sensor measurement circuit

Digital input signal is not checked by the controller.

If the no voltage contact signal is properly input to the digital input of the controller but controller finds it as abnormal or if there is no change of all digital input signals, it is because of the defective connection of I/O board power connector or no communication between I/O board and main board.

Check communication line connection status between I/O board and main board, and if there is no problem, short-circuit the connector of the wiring among the controller digital inputs that does not work to COM connector (23, 24) of controller I/O board to check whether LED LAMP corresponding to the I/O board input connector is lighted.

Select "menu key" – "system information" – "I/O input" of the controller display, short-circuit/open abnormal connectors and COM connector to see if input status changes to "ON"/"OFF".

When DC voltage between COM connector of the controller digital input and the wire released digital input, check if 18V is measured.

If there is no problem, connect them again and check operation.

If the corresponding board main power and communication is normal and I/O input still does not work the board needs to be replaced.

Check by referring to the below flow chart and tester connection diagram.

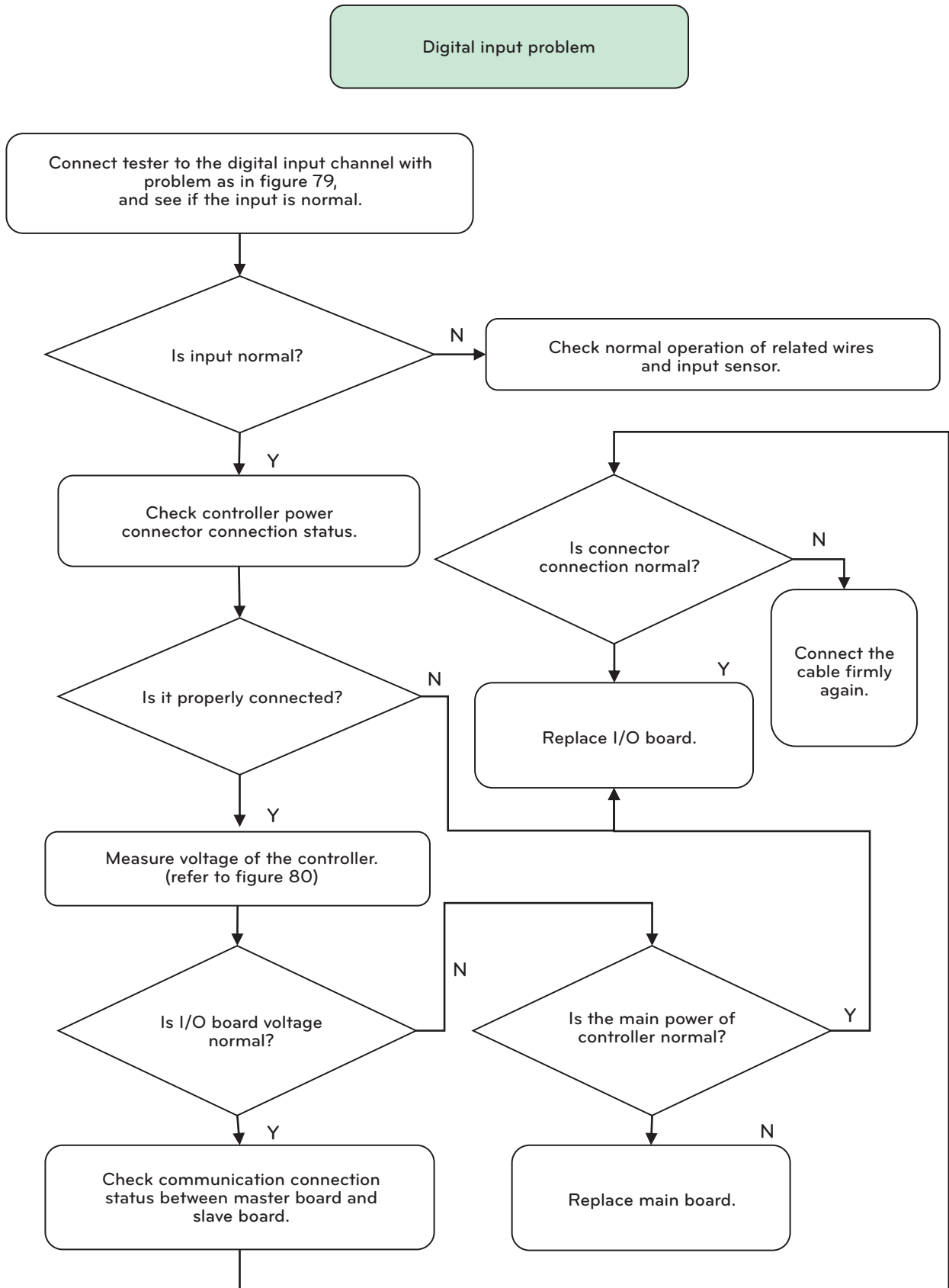

Figure 101. Digital input problem

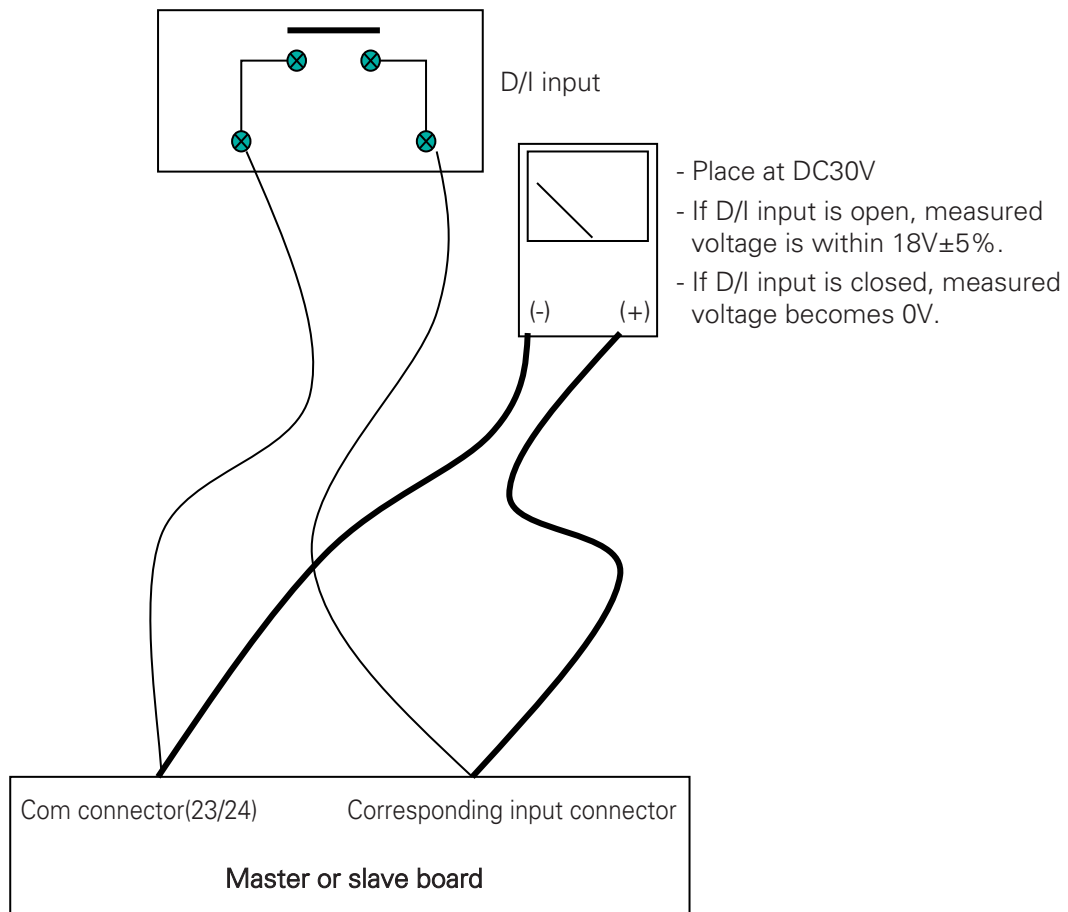

Figure 102. The current measurement circuit for master or slave board

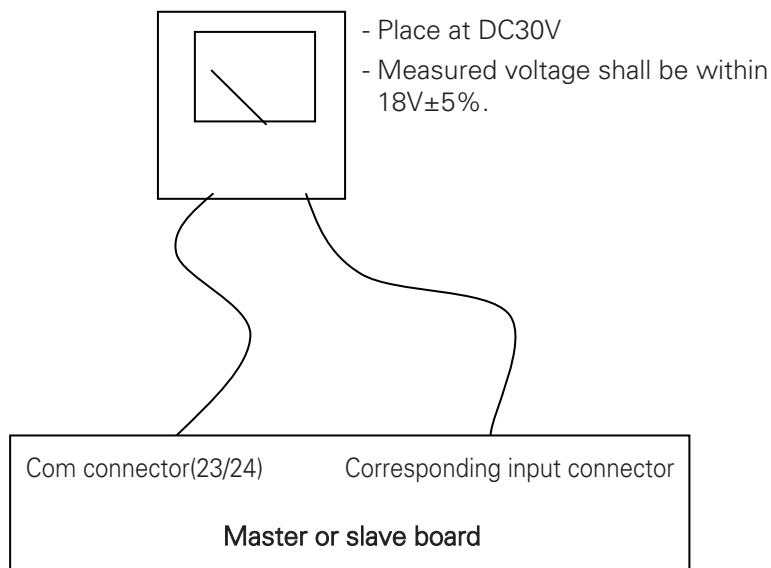

Figure 103. The current measurement circuit for master or slave board

Communication error

It is the error caused by no communication corresponding to the displayed message is made between each board. First, check communication line connection status between each board. At this time, 2 RDX+ and RDX- lines of master board shall be connected to the same polarity of RDX+ and RDX- of slave board and relay board, and 2 RDX+ and RDX- of master board shall be connected to the same polarity. If it is not properly connected to the corresponding communication connector, communication cannot be made, so it must be connected to the designated connector.

Abnormal rise of condensing pressure (cause of surge)

Status	Decision criteria	Cause	Remedy
Temperature difference between cooling water outlet and condensing is large.	Above 3°C	<ol style="list-style-type: none"> 1. Air is mixed into machine 2. Tube contaminated 3. Insufficient cooling water amount 4. Air taken in from cooling water pump intake 	<ol style="list-style-type: none"> 1. Clean tube 2. Check cooling water system and increase to specified amount 3. Enhance pump intake
Condensing pressure is high	9.5 kg/cm ² or more	<ol style="list-style-type: none"> 1. High Temp. Cooling water ▷ Lower the performance of cooling tower 2. Chilled water high temp. 3. Cooling water bypass in waterbox 4. Tubes contaminated 	<ol style="list-style-type: none"> 1. Check cooling tower performance 2. Lower chilled water temp. 3. Replace gasket in waterbox 4. Clean tube
Chilled water temperature is normal. However the temperature difference between the inlet and outlet of cooling water is large.	Check chiller data sheet	<ol style="list-style-type: none"> 1. Cooling water amount decreased 2. Air taken in from cooling water pump intake 	<ol style="list-style-type: none"> 1. Check the cooling water system and increase to specified amount 2. Enhance pump intake

Table 63. Master or Slave board current measurement circuit

Abnormal drop of evaporator pressure (cause of surge)

Status	Decision criteria	Cause	Remedy
Evaporating pressure is low and chilled water inlet/outlet temperature difference is small	-	<ol style="list-style-type: none"> 1. Butterfly valve adjustment defect 2. Insufficient chilled water amount 3. Tube contaminated 4. Insufficient refrigerant amount 	<ol style="list-style-type: none"> 1. Butterfly valve opening adjustment 2. Check chilled water system (flow) 3. Clean tube 4. Recharge refrigerant
Difference between evaporating temperature and chilled water outlet temperature is increased	Above 3°C	<ol style="list-style-type: none"> 1. Insufficient charging of refrigerant 2. Contamination of refrigerant 3. Decreased chilled water amount 4. Air mixed in chilled water 5. Chilled water bypass in waterbox 6. Tube contaminated 	<ol style="list-style-type: none"> 1. Add refrigerant 2. Clean refrigerant 3. Check chilled water system and increase to specified amount 4. Enhance chilled water pump intake 5. Replace gasket in waterbox 6. Clean tube

Table 64. Cause and Action for drop of evaporating pressure

Problem in lubrication system

Status	Decision criteria	Cause	Remedy
Oil pressure is low	(Oil discharge pressure – oil tank pressure) < 0.8 kg/cm ²	<ol style="list-style-type: none"> 1. Oil filter clogged 2. Insufficient oil 3. Pressure transducer defect 4. Oil pump defect 	<ol style="list-style-type: none"> 1. Oil filter cleaning or replacement 2. Recharge oil 3. Change transducer 4. Check if oil supply valves are closed 5. Check if oil temp. is low
Oil temp. is high in oil tank	74°C or more during operation	<ol style="list-style-type: none"> 1. Oil is not sufficiently supplied to bearing 2. Oil heater setting value defect 3. Refrigerant is not sufficiently supplied to oil cooler 4. Excessive oil amount 5. Bearing abrasion 	<ol style="list-style-type: none"> 1. Adjust oil pressure, and check oil filter, oil system. 2. Adjust set value 3. Check condensed refrigerant amount and filter drier. 4. Remove oil to make it adequate amount 5. Need disassembly and repair
Rapid change of oil pressure	-	<ol style="list-style-type: none"> 1. Oil manometer defect 2. Oil pump cavitation 3. Insufficient oil 	<ol style="list-style-type: none"> 1. Change manometer 2. Apply power to oil heater 3. Recharge oil
Oil tank temp. is low	Below 30°C	<ol style="list-style-type: none"> 1. Oil heater fuse disconnected 2. Oil heater disconnected 3. Black out for long time, power unit stopped 	<ol style="list-style-type: none"> 1. Replace fuse 2. Replace oil heater 3. Wait until oil tank temperature meets the specified temperature. And if it does not rise, contact LG service personnel.
Oil in oil tank increased when it is stopped	-	<ol style="list-style-type: none"> 1. Oil temperature is too low and oil is dissolved by solvent. 	<ol style="list-style-type: none"> 1. Check whether oil heater is disconnected. 2. Make sure the oil heater is on when the chiller unit shut down for long-term.

Table 65. Cause and action for problem in lubrication system

Others

Status	Decision criteria	Cause	Remedy
Compressor discharge temp. is low	-	1. Intake of fluid refrigerant	1. Extract adequate amount of refrigerant
Motor overload	-	1. Chilled water inlet temp. is high 2. Intake of liquid refrigerant 3. Intake of oil 4. Condenser high pressure 5. Gauge defect	1. Adjust chilled water temp. set value 2. Extract refrigerant 3. Regenerate refrigerant 4. Refer to 6-2-1 5. Change gauge
Abnormal vibration, current vibration	-	1. Oil pressure is higher than specification 2. A lot of fluid refrigerant intake 3. Bearing gap is big	1. Adjust to specified pressure 2. Extract refrigerant 3. Disassembly and inspection
Abnormal sound in compressor main body	-	1. Contact of the rotating part 2. Bearing abrasion, damage	1. Need to disassemble and repair 2. Need to disassemble and repair
Abnormal sound	-	1. Noise transferred from cooling water and chilled water pipe 2. Guide vane assembly defect 3. Isolation device defect	1. Apply flexible joint and spring isolator in the pipes 2. Reassemble or replacement 3. Replace isolator device
Moisture indicator turns yellow during operation	-	1. Moisture is 30ppm or more 2. Moisture indicator defect	1. Drain moisture in the machine 2. Replace moisture indicator
Insufficient chilling capability	-	1. Condensing pressure is high 2. Evaporating pressure is low 3. Gauge defect	1. Refer to 6-2-1 2. Refer to 6-2-2 3. Replace gauge
leak in shaft part capacity adjustment device	-	1. Shaft stop bolt is not tightened	1. Tighten stop bolt clockwise and check leakage

Table 66. Cause and countermeasure for chiller problems

9. OPERATION INSPECTION RECORD

9-1. Check list for operation record



Operation record table

R-134a (1-level/2-level), R-123

MODEL : _____

Manufacture NO. : _____

Measurement Category		Unit	1	2	3	4	5	6	7	8
		Hour:Min.	:	:	:	:	:	:	:	:
Chilled water	Inlet pressure	kg/cm ²								
	Outlet pressure	kg/cm ²								
	Inlet temp.	°C								
	Outlet temp.	°C								
	Chilled water flow	m ³ /h								
Evaporator	Pressure	kg/cm ²								
	Refrigerant temp.	°C								
Cooling water	Inlet pressure	kg/cm ²								
	Outlet pressure	kg/cm ²								
	Inlet temp.	°C								
	Outlet temp.	°C								
	Cooling W. Flow	m ³ /h								
Condenser	Pressure	kg/cm ²								
	Refrigerant temp.	°C								
Oil	TANK pressure	kg/cm ²								
	PUMP pressure	kg/cm ²								
	Differential pressure	kg/cm ²								
	Temp.	°C								
Compressor	Current limit value	%								
	Operating current	A								
	Winding temp.	°C								
	Temp. of Bearing	°C								
	Discharge gas temp.	°C								
	Vane opening	%								
	Diffuser opening	%								
Others		1. Chiller start time 2. Chiller stop time 3. Maintenance issues				4. Operation time 5. Number of start-ups 6. Moisture indicator color				

Table 67. Operation record table

