

LG 'IR Spread' based GHOST-FREE 42"/47" MULTI-TOUCH PREMIUM DISPLAY LT55A



GHOST-FREE MULTI-TOUCH EXPERIENCE

LG proprietary touch technology can draw clean and accurate diagonal lines through controlling multi-touch gestures in great precision.



Competitor Ghosting

LG Ghost-free

10 POINTS MULTI-TOUCH EXPERIENCE

Can be used in various high-traffic locations such as subway and exhibition halls for interactive way-finding and informational purposes with our improved 10 points touch monitors.



2 - 6 Point Competitor

10 Point LG

BUILT-IN MULTI-TOUCH

- No need to install external touch overlay
- Dust-free between touch frame and glass ensures high reliability
- Slimmer design is ideal for space at a premium



Competitor External Overlay

LG Built-in Touch

DOCKING-TYPE PROFESSIONAL SIGNAGE PLAYER

Compatible with MP500 player simplifies the cabling and reduces space limitations.



Hybrid Type Media Player

GREATER DURABILITY

LG premium signage display is highly durable and designed for operation 24 hours a day, seven days per week for virtually continuous business use.

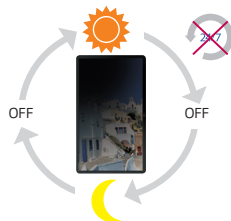

Normal Structure



PD Module Structure

LT55A 42"/47"

MULTI-TOUCH DISPLAY

LT55A 42", 47"



FEATURES

IPS Panel

- Low screen temperature on standard mode
- No blackening defect
- Wide viewing angle

Optimized Interactive Display

- Built-in touch display using IR spread type
- 10 touch points
- Ghost-free (*Ghosting : false touch point recognition during multi-touch)
- Anti-glare coating
- Greater durability of 24/7 operation
- Compatible with MP500 docking-type player

Energy Star® 6.0 compliant

SPECIFICATIONS

LT55A						
PANEL	Screen Size	42" / 47"	PHYSICAL SPECIFICATION	Packed Weight	42" : 24.7kg, 47" : 27.7 kg (TBD)	
	Panel Technology	IPS		VESATM Standard Mount Interface	400mm x 400 mm	
	Aspect Ratio	16 : 9		Temperature Sensor	Yes	
	Native Resolution	1920 x 1080 (FHD)		Auto Brightness Sensor	No	
	Brightness	450 cd/m ²		Brightness / Contrast / Backlight	Yes	
	Contrast Ratio	1,300 : 1		Position / Size	Yes	
	Dynamic CR	500,000:1		Auto Config / Phase	Yes	
	Viewing Angle (H x V)	178 x 178		Energy Saving	Yes (Minimum, Medium, Maxium)	
CONNECTIVITY	Response Time	12 ms (G to G)	SPECIAL FEATURES	Smart Energy Saving	Yes	
	Digital	HDMI(1), DVI-D(1), DP(1) with HDCP for all input		Environment Conditions	Operation Temperature	0 °C to 40 °C
	Analog	Component(1), Composite(1), RGB(1)		Operation Humidity	10 % to 80 %	
	Audio	RGB/DVI-D/AV/Component(3.5Φ 1)		POWER	Power Supply	100~240V, 50/60Hz
	Input (Rear)	External Control			Typ	TBD
	USB	Yes(1)			Smart Energy Saving	TBD
	HDTV Formats	Component		Component : 720p, 1080i, 1080p	DPM	TBD
		HDMI		HDMI : 720p, 1080i, 1080p	Power off	TBD
Digital		-	STANDARD (CERTIFICATION)	Safety	UL, cUL, CB scheme, TUV	
Analog		-		EMC	FCC Class "A", VCCI, C-tick, CE, KCC	
Output (Rear)	Audio	External Speaker	ErP / Energy Star	Yes / Yes (Energy Star 6.0)		
	External Control	-	MEDIA PLAYER COMPATIBILITY	Slot PC Compatible (Optional)	Yes	
	Bezel Width	25mm ↓ (TBD)		External Media Player Attachable	No	
	PHYSICAL SPECIFICATION	Monitor Dimension (W x H x D)	42" : 99.09cm x 58.5cm x 7.20cm (TBD, Head Only)	SOFTWARE COMPATIBILITY	SuperSign elite-w & lite	Yes
99.09cm x 58.5cm x 8.50cm (TBD, Head +MP500)			ACCESSORY		Included	Remote Controller, Power Cable, RGB Cable, Manual, ESG, IR Receiver
47" : 110.27cm x 64.78cm x 7.12cm (TBD, Head Only)				Optional	SP-2100(Speaker), ST-200T(Stand) MP500(Media Player)	
Weight (Head)		42" : 21.0kg, 47" : 24.0 kg (TBD)				
Carton Dimensions (W x H x D)	42" : 108.5cm x 74.0cm x 12.5cm (TBD)					
	47" : 118.7cm x 76.5cm, x 14.35cm (TBD)					

* Image may differ slightly from actual product. Specifications are subject to change without prior notice.

DIMENSION (unit : mm)

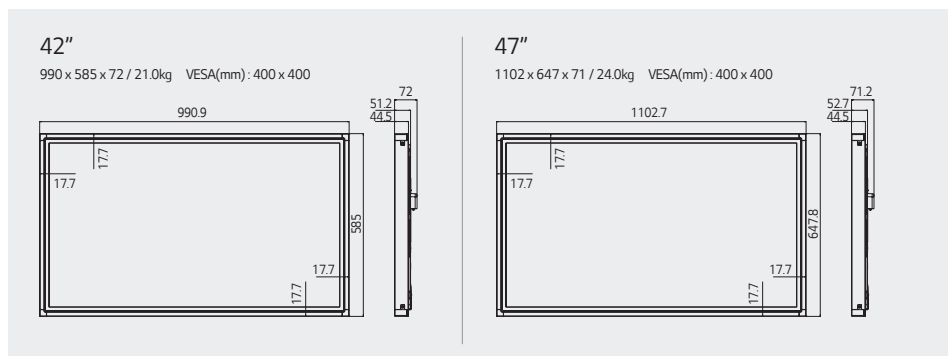

INTERFACE

