

Specifications

UW950H (EU)

		43	
DISPLAY	Type	Edge LED	
	Resolution	3,840 x 2,160 (UHD)	
	Brightness	330cd/m ²	
	Dynamic Contrast Ratio	1,000,000 : 1	
	Viewing Angle Degree	178° / 178°	
BROADCASTING SYSTEM	Analog	PAL / SECAM	
	Digital	DVB-T2/C/S2	
VIDEO	XD Engine	.	
	Real Cinema 24p (3:3 Pull down)	.	
	Aspect Ratio	6 modes (16:9, Original, 4:3, Vertical Zoom, All-Direction Zoom, Just Scan)	
AUDIO	Audio Output / Speaker System	10W+10W/2.0ch	
	Sound Mode	6 modes (Standard, Cinema, Clear Voice III, Sports, Music, Game)	
	Wireless Sound Sync	.	
GENERAL FEATURES	Type	Smart	
	Data Streaming (IP&RF)	.	
	Pro:Centric® Pro:Centric Application	PCA 3.7	
	RF (1/2 Tuner)	RF (1)	
	HCAP (SDK)	GEM / Flash / HTML5	
	Smart Features	Commercial Smart Home, Web Browser, softAP, Magic Remote (Ready)	
	Connectivity	WiDi, Smart Mirroring, WiFi Direct, DIAL, Bluetooth Sound Sync	
	DRM (Digital Right Management)	ProIdiom	
	Management	Remote Diagnostics, EzManager (for initial configuration)	
	Interactivity	HTNG/HDMI-CEC	
	RJP Interface	RS232C, HDMI	
Advanced Setting Option	Auto Off / Auto Sleep, Motion Eye Care, Energy Saving		
Anti-theft System	Kensington Lock		
HOSPITALITY FEATURES	Hotel Mode, Lock Mode, IR Out, External Speaker Out, External Power, USB Cloning, One Channel Map, Multi IR Code, Welcome Screen, Instant On, TV Link Interactive, External Clock Ready, RTC (Real Time Clock), SNMP		
INTERFACE	Side	HDMI In, USB (2), CI Slot	
	Rear	RF In (2), AV In, Video Component In (Phone Jack Type), Digital Audio Out (Optical), HDMI Input, RS-232C, Headphone Out, Clock Interface, LAN port (2), External Speaker Out (2)	
CABINET (Unit : mm)	Vesa	200 x 200	
	WxHxD / weight (with stand)	971 x 630 x 176 / 12.1kg	
	WxHxD / weight (Carton)	1,060 x 660 x 142 / 14.1kg	
POWER (Unit : Watts)	Voltage, Hz	100-240V, 50 / 60 Hz	
	Max (Watts)	133.7	
	Typical (Watts)	110.2	
	Energy saving (Min)	88.2	
	Energy saving (Med)	60.6	
	Energy saving (Max)	33.1	
	Stand-by	0.3 ↓	
	Safety	CB, CU TR	
STANDARD APPROVAL	Environment	CE	
	Etc	ROHS, ErP, Eco flower (EU only)	
	Eco	ErP Class	A+
		On Power Consumption	51W
		Luminance	65%
		Mercury	0 mg
		Presence of Lead	Yes
Average Annual Consumption (kWh)	74		

Pro:Centric® SMART

UW950H (EU)

A Premium Smart Solution With a Sleek ULTRA HD Display

Provide your guests with the interactive smart solution, Pro:Centric® SMART, for a superior experience. The UW950H's stunning design plays a significant role to elevate the ambience in any hotel room while it enables you to customize and create your own content with SDK Tools, Pre-loaded Apps, and content management software, Pro:Centric Direct (Option). Also, ULTRA HD picture quality and guest-centric technologies increase guests' satisfaction and make a lasting impression on the hospitality properties.

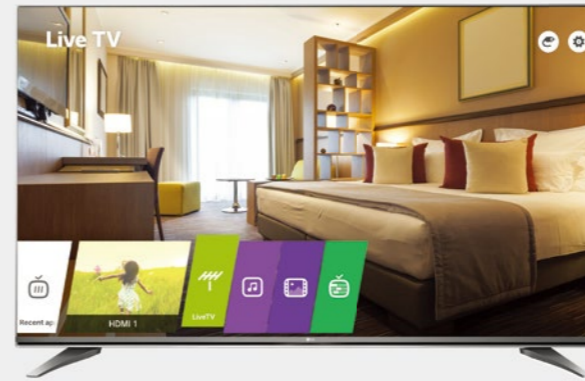

UW950H

- Pro:Centric® Smart
- ^{NEW} Pro:Centric Direct Ready
- ULTRA HD
- ULTRA Slim & CINEMA SCREEN
- Frontal Speaker
- Pro:Idiom®
- Bluetooth Sound Sync

screen size
43"

Key Features



Smart Customization

Create your own solution along with LG's smart customization tools and content management software. With the tailored solution, hotel can elevate their brand to new levels.

Features

- Pro:Centric Smart SDK (HTML5, Java, Flash)
- ^{NEW} Pro:Centric Direct Ready
- Pre-loaded Apps

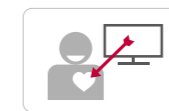

Enhanced guests' Experience

Delight your guests with vivid picture quality and entertaining features including webOS 3.0 and its smart apps. It captivates guests' taste and brings them again.

Features

- ULTRA HD
- 4K Upscaler, IPS Wide Viewing Angle
- webOS 3.0 & Magic Remote (Ready)



Smart Connectivity

Cross display boundaries freely and without hassle. With LG SmartShare, mirroring and content sharing between TV and other smart devices are made incredibly easy and user-friendly.

Features

- Smart Share (WiDi, Smart Mirroring, WiFi Direct, DIAL)
- Bluetooth Sound Sync

Dimensions

43"

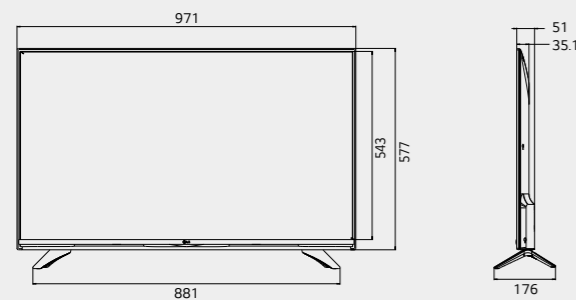

Connectivity

- | | | |
|----------------|-----------------------------|-----------------------|
| 1 CLOCK | 6 OPTICAL DIGITAL AUDIO OUT | 11 LNB Satellite IN |
| 2 RS-232C IN | 7 HDMI IN 1 | 12 ANTENNA / CABLE IN |
| 3 AUX LAN | 8 AV IN | 13 HDMI IN 2 |
| 4 LAN | 9 H/P OUT | 14 USB IN 1 |
| 5 COMPONENT IN | 10 SPEAKER OUT | 15 USB IN 2 |

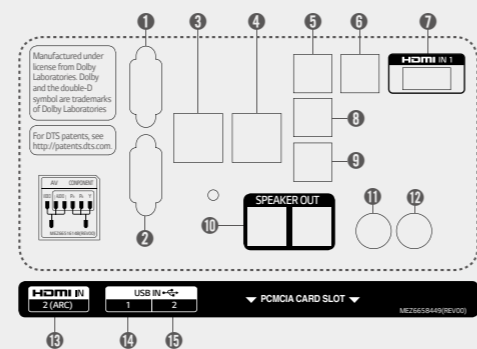

Download LG Commercial Display Mobile App



Learn more www.lg.com/b2b or www.lgcommercial.com

YouTube youtube.com/c/LGCommercialDisplay

All screen images are simulated. Dimension and weights are approximate. Design, features and specifications subject to change without notice. © Copyright 2016 LG Electronics Inc. All Rights Reserved. Pro:Centric, the "LG" logo, XD Engine are registered trademarks or trademarks of LG Electronics Inc. ProIdiom is a registered trademark of Zenith Electronics LLC. All other trademarks or registered trademarks are the property of their respective owners.



Hospitality Features

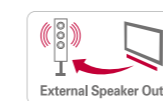

External Speaker Out

The external speaker out function lets users enjoy the external speaker in a separate place such as the bathroom.

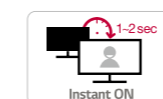

Instant ON

Instant on function's high speed loading system saves and enables users to enjoy the contents immediately when they first turn on the TV.

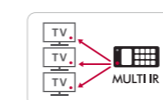

Multi IR

Multi IR function eliminate the remote control signal interference between TVs in multiple dwelling beds.



Pro:Idiom®

Prevent any illegal copying of content by the widely used DRM (Digital Right Management).

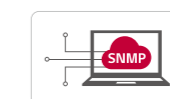

SNMP

SNMP (Simple Network Management Protocol) ensures convenient network management for SI and business managers.

A Premium Smart Solution With a Sleek ULTRA HD Display

Pro:Centric® Smart UW950H

Pro:Centric® SMART

EU

Pro: Centric Smart is an elaborate and smart mode of control and customization for commercial televisions. With the customizable tools including HTML5, Java, and Flash, users can optimize the commercial TVs according to their purposes with IP-based programs. This expansion of control provides premium hotel services to guests without the need for a set-top box. Additionally, as the Pro:Centric Smart models are compatible with Pro:Centric Server Application, you can remotely manage TVs in a centralized coaxial infrastructure you already have.

Pro:Centric Smart Application Platform

LG Pro:Centric SMART offers extended customizable tools; HTML5, Java and Flash. With these, the partners can optimize Commercial TVs to edit and develop their own enhanced service design. Also, it gives visual impact on and delivers messages to customers as users intend.

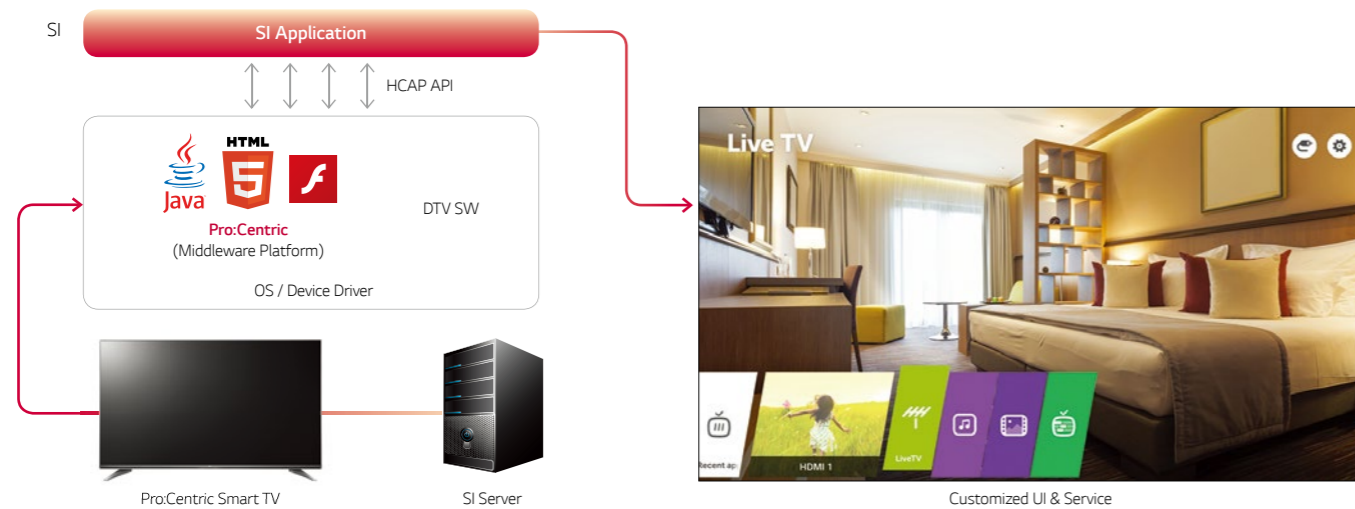

Pro:Centric Server Application

You can now differentiate your hotel with our customizable templates and pages which can be specialized for your property. Pro:Centric® provides you a solution that is easily customizable for your business.

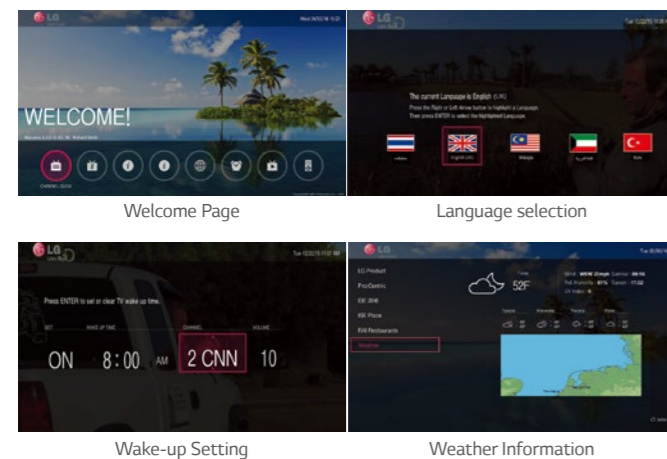

• Various Features

PCA serves the convenience of the guest through a Wake-up setting, Weather Information, Map Service, and much more functions that you can choose.

• Customizable Template & Page

Choose an alternative look & feel template based on your reference, and edit multiple sections with 40 pages of billboards by yourself with the web based tool.

Pro:Centric Direct Support

Simply create your own templates and remotely manage TVs on the IP network with Pro:Centric Direct, LG's content management software. Pro:Centric Direct offers a free design template, along with customizable widgets and three types of theme templates (Cinematic-type, Grid-type, Bar-type)* in order to promote branding and meet guests' tastes and needs. Its interactive solution, including 1-click service, and intuitive UI impress guests while elevating their hotel experience. Plus, for hoteliers, not only does it offer efficient content production and management, but it also maximizes advertisement effectiveness, which contributes to improving the hotel brand.

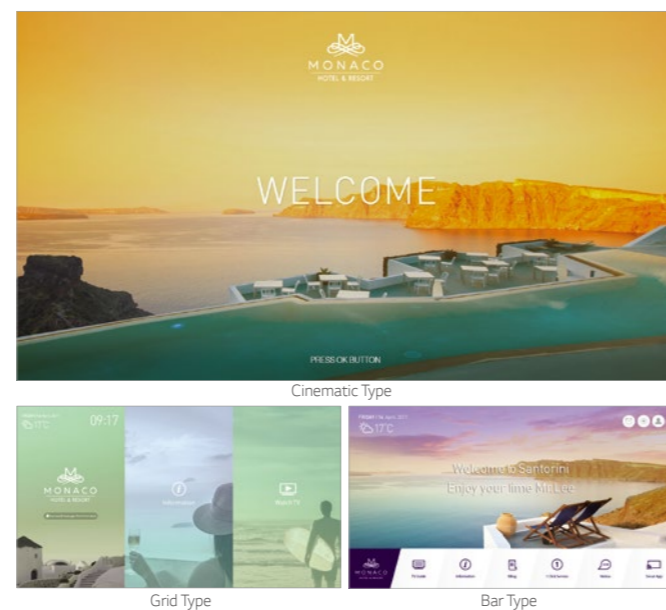

*Three types of templates will be available after Dec. 2016.

ULTRA HD TV

4K Resolution

ULTRA HD is the future of digital picture, possessing four times higher resolution than that of full HD. Stunning 8.3 million pixels gives a flawless picture quality and incredibly vivid detail.



4K Upscaler

Enjoy Full HD content in 4K ULTRA HD quality. The 4K Upscaler automatically upgrades Full HD content to ULTRA HD through the six steps of the upscaling processes.



4K IPS Wide Viewing Angle

One of the secret behind LG TVs outstanding viewing experience is the specially designed TV panel. 4K IPS delivers true colour from any angle with 4 times the resolution of Full HD. With 4K IPS, every seat is the best for watching content in your space.



Premium Design & Sound

ULTRA Slim

The thickness of a TV is reduced innovatively. The ULTRA Slim design provides excellent space efficiency and greatly fits for wall-mounting.



CINEMA SCREEN

CINEMA SCREEN design brings the cinematic viewing experience through the minimized bezel. With the narrow bezel, not only your guests can enjoy immersive viewing experience, but you also convey messages in a more effective way.



Frontal Speaker

With a built-in forward facing, frontal speaker system, guests will enjoy truly powerful room-filling sound for a more immersive entertainment experience.



Smart Connectivity & Convenience

Smart Share

Smart Share allows users to share content more easily and quickly. It also searches for the content they want in order to share it more easily and accurately, thereby simplifying the process of sharing between various devices.



Bluetooth Sound Sync (Bluetooth 3.0)

Bluetooth Sound Sync enables users to listen to music on a mobile device through TV speakers via Bluetooth connection.

* Support devices for Bluetooth Sound Sync : Android (above v4.4 KitKat) / iOS based Mobile Device



SoftAP

SoftAP means Software enabled Access Point. This "Virtual" Wi-Fi feature executes by software working on the device to create a wireless hotspot.

* SoftAP should be set in installation menu after TV is on. * Smart Mirroring may not be operated at the same time.

